



# airoheat®

heat pump specifications

## highly efficient

direct heat transfer for outstanding efficiency

## intelligent Hotlogic®

innovative de-icing function for cold climates

## recognised excellence

Australia's most highly awarded environmental water heater



1300 365 116

[www.dux.com.au](http://www.dux.com.au)

# airoheat® heat pump system

## Why is Airoheat so efficient?

Let's consider the efficiency of Airoheat in two parts.

The first part is the efficient creation of the heat using state of the art components.

The second part is how and where the heat is transferred into the water. What makes Airoheat so efficient is that the heat transfer occurs within the water inside the tank. As a result it gets direct heat transfer and isn't exposed to some of the heat loss issues associated with other styles of heat pump water heaters.

## Airoheat new features

- increased hot water delivery due to new inlet diffusion technology

- improved lid design for rapid drainage in high rainfall areas
- easy access to both anodes for ease of maintenance
- improved hot water recovery time
- improved thermal efficiency, less heat loss due to fully insulated storage tank and refrigeration system
- a 50mm reduction in height to allow for more compact installations
- composite condensation tray
- improved airflow dynamics
- hard wired electrical connection.



## STCs Table - Heat Pump

PRODUCT CODE: D2FHG4HW0C		STCs ZONE				
		1	2	3	4	5*
250 Litres	Airoheat heat pump	22	21	26	27	27*

\* Refer to [www.dux.com.au/zones](http://www.dux.com.au/zones) for postcodes in Zone 5.

STC values are subject to change without notice and are correct at time of printing. STCs calculations are based on continuous tariff.

SPECIFICATIONS	AIROHEAT
Capacity	250L
Net weight empty	107 kg
Power consumption (general tariff)	1.2 kW
Max water supply pressure	800kPa
Relief valve pressure	1000kPa
Free air flow	1500 m <sup>3</sup> /h
Rated voltage	240V ac
Evaporator area	0.36 m <sup>2</sup>

Not suitable for installation in alpine areas or areas above 1000m.

CAPACITY (LITRES)	PEOPLE
250	3-5

Size figures are based on environmental averages which can effect the performance of solar and heat pump heaters. Adult icon can represent dishwasher or washing machine. An adult icon does not represent a spa bath. Based on connection to continuous tariff.

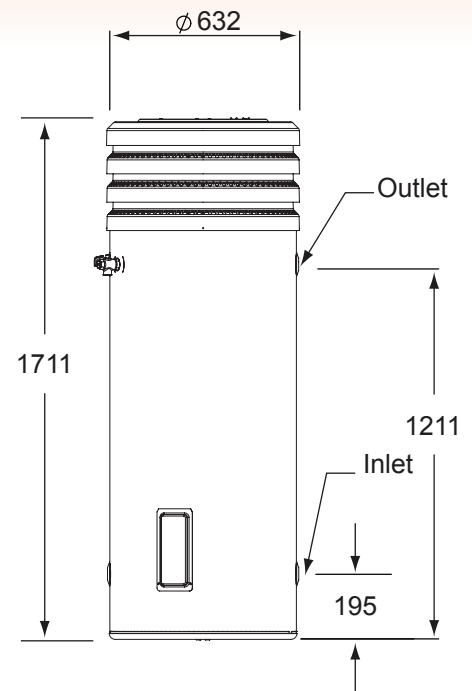

### Warranty

Full warranty terms and conditions are in the product's Owner's Manual ("the warranty"), which you must comply with for a warranty claim to be honoured by Dux.

Our goods come with guarantees that cannot be excluded under the Australian Consumer Law. You are entitled to a replacement or refund for a major failure and for compensation for any other reasonably foreseeable loss or damage. You are also entitled to have the goods repaired or replaced if the goods fail to be of acceptable quality and the failure does not amount to a major failure.

Under the warranty, the transport, installation and labour costs of delivering the replacement hot water unit or solar collector and removing and replacing the existing hot water unit or solar collector with the replacement hot water unit or solar collector will be your responsibility, unless otherwise agreed by Dux. The benefits provided to you by the warranty are in addition to the guarantees and other rights and remedies available to you under the Australian Consumer Law.

### How to Make a Warranty Claim

Warranty claims can be made at the point of sale or by posting or faxing a warranty claim to the manufacturer (contact details listed below) within one (1) month of the appearance of a defect. Warranty claims must include the following details: date of purchase, location of purchase, proof of purchase, date of installation, contact details, and product serial number.

### Manufacturer's Contact Details

Address: Dux Manufacturing Limited, Lackey Road, Moss Vale, NSW, 2577, Australia • Telephone: 1300 365 115 (Australia), 0800 729 389 (New Zealand) • Email: [marketing@dux.com.au](mailto:marketing@dux.com.au)



## Contact Dux for your Hot Water Solutions

Sales: 1300 365 116 Service: 1300 365 115 Web Site: [www.dux.com.au](http://www.dux.com.au)

©Dux Manufacturing Limited ABN 19 077 879 844. Lackey Rd, PO Box 209 Moss Vale, NSW 2577

The information supplied was correct at time of printing. Specification and materials may change without notice.

® and ™ indicate trademarks of Dux Manufacturing Limited. Dux Manufacturing Limited is part of a publicly listed Australian company.

RTA: AU12953



GWA  
Smarter Solutions