



sunpro[®]

electric boosted solar specifications

thinkefficiency

outstanding efficiency to help reduce energy bills

thinkinnovation

part of Australia's most highly awarded range of environmental water heaters



1300 365 116

www.dux.com.au

sunpro[®] electric boosted solar

Why you should choose a Dux Sunpro[®] electric boosted solar system

- Next generation split system design with tank on the ground
- Multi-temperature sensor vitreous enamel tank configuration
- High performance black chrome selective surface collectors as standard
- Patented Hotlogic[®] processor that constantly searches for and switches to the cheapest available energy source
- As the element is located midway up the tank, it heats up the top half of the tank only. Thus, in a 400L tank, only 200L of water is heated. This provides the benefits of solar power while minimising electricity costs.



TANK	250L	315L	400L
Storage Capacity	259	324	416
Hot Water Delivery Rating (Litres) – tank	250	315	400
Net Tank Weight Empty (kg)	81	94	114
Relief Valve Pressure (kPa)	1000	1000	1000

CAPACITY (LITRES)	PEOPLE	
250		2-4
315		3-5
400		4-7

Size figures are based on environmental averages which can effect the performance of solar & heat pump heaters. Adult icon can represent dishwasher or washing machine. An adult icon does not represent a spa bath.

NOMINAL DIMENSIONS (MM)	250L	315L	400L
Tank Height (A)	1444	1754	1703
Tank Diameter (B)	617	617	705
Tank Width (C)	712	712	801
Outlet (D)	1211	1521	1445
Inlet (E)	195	195	219
Solar Return (F)	628	838	642

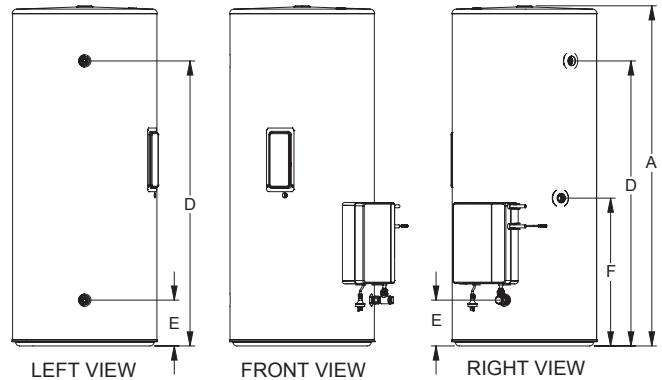
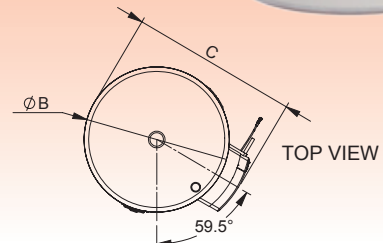

STCs Table – Electric Boosted		STC ZONE				
OPEN CIRCUIT SYSTEMS	COLLECTORS	1	2	3	4	
250L	D2F136T2AC	2	38	41	36	32
315L	D3F136T2AC	2	38	42	37	32
400L	D4F136T3AC	3	44	45	45	40

Calculations are based on Dux 2AP style collector. STCs calculations are based on Continuous Tariff. STC values are subject to change without notice and are correct at time of printing.



Did you know

As a guarantee of performance all Dux[®] solar water heaters are supplied with a genuine Reliance[®] brand Dux[®] solar tempering valve. These valves have been adjusted to Dux specification to ensure maximum hot water delivery.



Warranty

Full warranty terms and conditions are in the product's Owner's Manual ("the warranty"), which you must comply with for a warranty claim to be honoured by Dux.

Our goods come with guarantees that cannot be excluded under the Australian Consumer Law. You are entitled to a replacement or refund for a major failure and for compensation for any other reasonably foreseeable loss or damage. You are also entitled to have the goods repaired or replaced if the goods fail to be of acceptable quality and the failure does not amount to a major failure.

Under the warranty, the transport, installation and labour costs of delivering the replacement hot water unit or solar collector and removing and replacing the existing hot water unit or solar collector with the replacement hot water unit or solar collector will be your responsibility, unless otherwise agreed by Dux. The benefits provided to you by the warranty are in addition to the guarantees and other rights and remedies available to you under the Australian Consumer Law.

How to Make a Warranty Claim

Warranty claims can be made at the point of sale or by posting or faxing a warranty claim to the manufacturer (contact details listed below) within one (1) month of the appearance of a defect. Warranty claims must include the following details: date of purchase, location of purchase, proof of purchase, date of installation, contact details, and product serial number.

Manufacturer's Contact Details

Address: Dux Manufacturing Limited, Lackey Road, Moss Vale, NSW, 2577, Australia • Telephone: 1300 365 115 (Australia), 0800 729 389 (New Zealand) • Email: marketing@dux.com.au



Contact Dux for your Hot Water Solutions

Sales: 1300 365 116 Service: 1300 365 115 Web Site: www.dux.com.au

©Dux Manufacturing Limited ABN 19 077 879 844. Lackey Rd, PO Box 209 Moss Vale, NSW 2577

The information supplied was correct at time of printing. Specification and materials may change without notice.

© and TM indicate trademarks of Dux Manufacturing Limited. Dux Manufacturing Limited is part of a publicly listed Australian company.



GWA
Smarter Solutions