

Owner's Guide and Installation Instructions

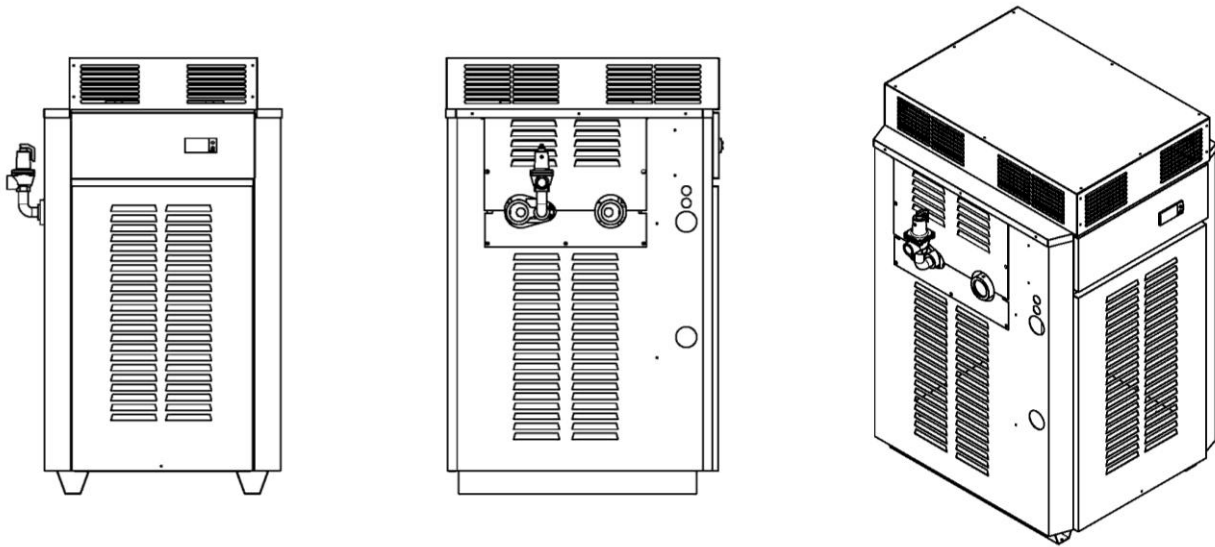

Raypak Water Heaters



<i>Models</i>	<i>Types</i>
B0200	
B0280	NCO, NCM
B0350	PCO, PCM
B0430	

This water heater must be installed and serviced by a qualified person.
Please leave this guide with a responsible officer.

**Notice to Victorian Customers from the
Victorian Plumbing Industry Commission**

**This water heater must be installed by a licensed person as required by
The Victorian Building Act 1993**

Only a licensed person will give you a Compliance Certificate, showing that the work complies with all the relevant standards. Only a licensed person will have insurance protecting their workmanship for 6 years. Make sure you use a licensed person to install this water heater and ask for your Compliance Certificate.

⚠ Warning: Upon completion of the installation and commissioning of the water heater, leave this guide with the householder or a responsible officer. **DO NOT** leave this guide inside of the cover of the water heater, as it may interfere with the safe operation of the water heater or ignite when the water heater is turned on.

Date of installation:

Model N°:

Serial N°:

Installed by:

Purchased from:

PATENTS

This water heater may be protected by one or more patents or registered designs.

® Registered trademark of Rheem Australia Pty Ltd.

™ Trademark of Rheem Australia Pty Ltd.

CONTENTS

HOUSEHOLDER OR RESPONSIBLE OFFICER – We recommend you read pages 4 to 10.

The other pages are intended for the installer but may be of interest

CONTENTS	3
ABOUT YOUR WATER HEATER	4
HOW YOUR WATER HEATER WORKS	7
SAVE A SERVICE CALL	8
REGULAR CARE	10
INSTALLATION	11
CONNECTIONS – PLUMBING	17
CONNECTIONS – ELECTRICAL	20
LOCATION OF CONTROLS	25
SAFETY PRECAUTIONS	26
COMMISSIONING	27
OPERATING THE WATER HEATER	28
TEMPERATURE CONTROL	30
SERVICE PROCEDURES	34
WATER SUPPLIES	35
WARRANTY	39

ABOUT YOUR WATER HEATER

WATER HEATER APPLICATION

This water heater is designed for the purpose of heating for potable water or hydronic heating applications. Its use in an application other than this may shorten its life.

MODEL TYPE

Congratulations for choosing a Raypak® water heater. The model you have chosen is suitable for either indoor or outdoor installation depending on use of the appropriate installation kit.

The operation of the water heater depends on the application. Typically for hot water applications a water heater with 'on/off' operation will be installed. For mechanical heating or process applications a water heater with 'modulating' operation will be installed.

HOW HOT SHOULD THE WATER BE?

The water heater features an adjustable thermostat, which allows the most suitable temperature for the application to be chosen.

To meet the requirements of the National Plumbing Standard the temperature of the stored water for hot water applications must not be below 60°C.

HOTTER WATER INCREASES THE RISK OF SCALD INJURY

This water heater can deliver water at temperatures which can cause scalding. Check the water temperature before use, such as when entering a shower or filling a bath or basin, to ensure it is suitable for the application and will not cause scald injury.

We recommend and it may be required by regulations that an approved temperature limiting device be fitted into the hot water piping to the bathroom and ensuite when this water heater is installed. This will keep the water temperature below 50°C at the bathroom and ensuite. The risk of scald injury will be reduced and still allow hotter water to the kitchen and laundry.

TEMPERATURE ADJUSTMENT

The thermostat temperature will have been set by the installer to suit the application, adjustment should not be required. Consult your installer before making any adjustment to the thermostat temperature.

⚠ WARNING

This water heater is only intended to be operated by persons who have the experience or the knowledge and the capabilities to do so. This water heater is not intended to be operated by persons (including children) with reduced physical, sensory or mental capabilities, or lack of experience and knowledge.

Children should be supervised to ensure they do not interfere with the water heater.

The water heater uses 240 Volt AC electrical power for operation of the control systems. The removal of the access cover(s) will expose 240 V wiring. They must only be removed by an authorised or qualified person.

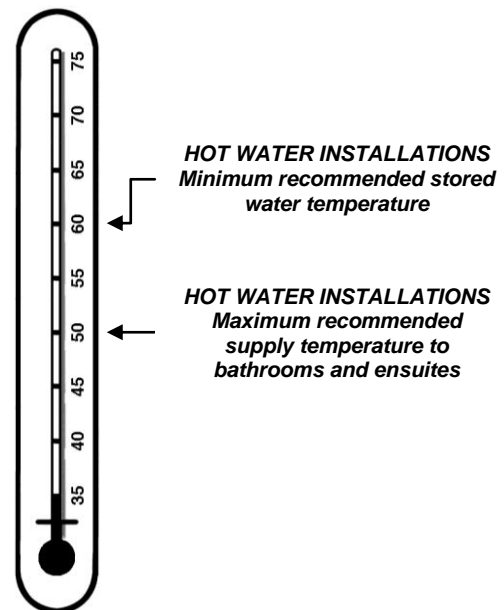

SAFETY

For your safety do not operate this water heater before reading this instruction booklet.

This water heater is supplied with a thermostat, hi-limit thermostat and a pressure relief valve. These devices must not be tampered with or removed. The water heater must not be operated unless each of these devices is fitted and is in working order.

Improper installation, adjustment, alteration, service or maintenance can cause injury or property damage. For assistance or additional information consult your Raypak distributor, qualified installer, or Rheem® Service agent.

The Raypak warranty can become void if relief valves or other safety devices are tampered with or if the installation is not in accordance with these instructions.

- DO NOT store **flammable or combustible materials** near the water heater. Flammable liquids (such as petrol), newspapers and similar articles must be kept well away from the water heater and the draught diverter or flue terminal.
- DO NOT use **aerosols, stain removers and household chemicals** near the water heater whilst it is working. Gases from some aerosol sprays, stain removers and household chemicals become corrosive when drawn into a flame.
- DO NOT store **swimming pool chemicals, household cleaners, etc.**, near the water heater.
- DO NOT place anything on top of the water heater or in contact with the flue terminal. Ensure the flue terminal is not obstructed in any way at any time.
- DO NOT use Propane / Butane gas mixtures in a Propane model. A Propane model is designed to operate on Propane only. The use of Propane / Butane mixture, such as automotive LPG fuel, in a Propane model is unsafe and can cause damage to the water heater.
- DO NOT operate with panels, covers or guards removed from the water heater.
- DO NOT enclose this water heater (applies to external installations only).



If the power supply cord or electrical conduit to the water heater is damaged, it must be replaced by an authorised person in order to avoid a hazard. The power supply cord and plug must be replaced with a genuine replacement part available from Rheem. Phone your nearest Rheem Service Department or Accredited service Agent to arrange for an inspection.

Do not use the water heater if any part has been under water. Immediately call Rheem Service or Accredited service Agent to arrange for an inspection.

WHAT TO DO IF YOU SMELL GAS?

- DO NOT try to light any gas appliance.
- DO NOT touch any electrical switch.
- TURN OFF the gas supply at the gas meter immediately, call your gas supplier or licensed gasfitter.

NOTE: Some gases are heavier than air and it may be necessary to check for gas leaks at floor level.

TO TURN OFF THE WATER HEATER

If it is necessary to turn off the water heater:

- Switch off the electrical supply at the power outlet to the water heater
NOTE: If the water heater is correctly installed, this will also shut down the circulating pump.
- Close the gas isolation valve at the inlet to the water heater.
- Close the cold water isolation valve at the inlet to the water heater.
- Close the isolation valves on the cold and hot water branches to shut down an individual water heater in a bank (water heating applications only).

TO TURN ON THE WATER HEATER

⚠ WARNING! If you smell gas do not attempt to turn on the water heater.

- Fill the system with water (refer to “[To Fill the Water Heater](#)” on page 28)
- Open the gas isolation valve fully at the inlet to the water heater.
- Plug in the power supply cord at the power outlet.
- Switch on the electrical supply at the power outlet to the water heater.

NOTE: If the water heater is correctly installed, this will also activate the circulating pump.

The water heater will operate automatically when a call for heat occurs.

HOW DO I KNOW IF THE WATER HEATER IS INSTALLED CORRECTLY?

Installation requirements are shown on [pages 11 to 16](#). The water heater must be installed:

- by a qualified person, and
- in accordance with the installation instructions, and
- in compliance with Standards AS/NZS 3500.4, AS 5601 or AS/NZS 5601.1, as applicable under local regulations, and all local codes and regulatory authority requirements.

In New Zealand, the installation must also conform with NZS 5261, as applicable under local regulations, and the New Zealand Building Code.

DOES THE WATER CHEMISTRY AFFECT THE WATER HEATER?

The water heater is suitable for most public water supplies, however some water chemistries may have detrimental effects on the water heater, its components and fittings. Refer to “[Water Supplies](#)” on page 35.

If you are in a known harsh water area or you are not sure of your water chemistry, have your water checked against the conditions [described on pages 35](#).

HOW LONG WILL THE WATER HEATER LAST?

The water heater is supported by a manufacturer’s warranty ([refer to page 39](#)). There are a number of factors that will affect the length of service the water heater will provide. These include but are not limited to the water chemistry, the water pressure, the water temperature (inlet and outlet) and the water usage pattern. Refer to “[Precautions](#)” on page 6.

PRECAUTIONS

Where damage to property can occur in the event of the water heater leaking, the water heater must be installed in a safe tray. Construction, installation and draining of a safe tray must comply with AS/NZS 3500.4 and all local codes and regulatory authority requirements.

The water heater must be maintained in accordance with the Owner’s Guide and Installation Instructions. Refer to “[Regular Care](#)” on page 10.

If this water heater is to be used where an uninterrupted hot water supply is necessary for your application or business you should ensure that you have back up redundancy within the hot water system design. This should ensure the continuity of hot water supply in the event that this water heater were to become inoperable for any reason. We recommend you seek advice from your plumber or specifier about your needs and building back up redundancy into your hot water supply system.

SERVICING

For safe and efficient operation, the water heater should be serviced annually by your nearest Rheem Service Department or their Accredited Service Agent. Only genuine replacement parts should be used on this water heater. Refer to “[Service Procedures](#)” on page 34

⚠ WARNING: Servicing of a gas water heater should only be carried out by qualified personnel.

HOW YOUR WATER HEATER WORKS

The water heater consists of a gas burner, a combustion chamber lined with refractory tiles and a heat-exchanger made of finned copper tubes. Hot flue gases from the burner pass between the fins on the heat exchanger tubes and heat is transferred first to the fins and then by conduction into the water. Baffles are placed between the tubes to control the flow of the hot flue gases and ensure efficient operation of the water heater. The refractory tiles insulate the combustion chamber to minimise loss of heat and protect the surroundings from the temperature of the burner flames. The gas supply to the burner is controlled by a thermostat, which senses the temperature of the water.

Automatic safety controls are fitted to the water heater:

- to ensure safe ignition of the gas whenever there is a call for heating;
- to continuously monitor the burner flame; and
- to prevent excessive temperatures or pressures in the water system.

MAINS PRESSURE

In water heating applications, the water heater is designed to operate in conjunction with one or more hot water storage tanks, which would be connected directly to the mains water supply. If the mains supply pressure in your area exceeds the value shown in the table on page 14 or the maximum inlet pressure for the storage tanks, a pressure limiting valve must be fitted.

In mechanical and process heating applications, the system pressure must not exceed the value shown in the table on page 14.

ELECTRONIC THERMOSTAT (ON/OFF MODELS)

On/Off models are fitted with an electronic thermostat that operates the gas control by switching its power on and off, so a constant temperature is maintained. The thermostat is mounted on the control panel of the water heater and the protective over temperature cut out is mounted inside the lower front cover of the water heater.

There is no need to switch the water heater off when it is not in use. The thermostat is fully automatic and only allows the gas control to open when the burner requires gas for heating. The thermostat may flash "AH" (alarm high) and the current water temperature, or "AL" (alarm low) and the current water temperature. This is not a cause for concern unless the temperature displayed is more than 10°C above the set temperature. Refer to "[Diagnostic Features of Electronic Thermostat](#)" on page 8. To adjust the thermostat settings refer to "[Temperature Control](#)" on page 30.

MECHANICAL CONTROL (MODULATING MODELS)

Modulating models are fitted with a mechanical modulating gas control that varies the gas flow to the burner in order to maintain a constant temperature. The temperature adjustment is on the body of the modulating control, mounted inside the lower front cover of the water heater. The protective over temperature cut out is also mounted inside the lower front cover of the water heater.

To adjust the thermostat setting refer to "[Temperature Control](#)" on page 33.

BURNER IGNITION

The water heater incorporates an automatic burner ignition system, incorporating an automatic pilot burner, which lights the main burner gas when the thermostat registers a need for heating.

On/Off models have a hot surface igniter (HSI) that heats up when there is a call for heating. When the HSI probe is up to temperature, a valve opens allowing gas to the pilot burner and this is ignited by the HSI probe. When successful ignition of the pilot flame is detected, the valves open to supply gas to the main burner. If the pilot fails to ignite after two attempts, the ignition system will lock out.

Modulating models have a spark generator that begins operating when power is applied and any external controls call for the water heater to operate. At the same time a valve opens to supply gas to the pilot burner. After successful ignition of the pilot flame has been detected, the valves open to supply gas to the main burner, when there is a call for heating. If the pilot fails to ignite within 15 seconds, the ignition system will lock out.

SAVE A SERVICE CALL

Check the items below before making a service call. You will be charged for attending to any condition or fault that is not related to manufacture or failure of a part.

NOT ENOUGH HOT WATER (OR NO HOT WATER)

- **Is the electricity switched on?**
Inspect the power outlet adjacent to the water heater and ensure the water heater is plugged in and the outlet is turned on.
- **Is there a time clock on the power supply?**
Check the settings on the time clock and ensure they are suitable to enable heating when it is required.
- **Is the ignition system 'locked out'?**
Reset the water heater. Refer to ["Water Heater Not Operating"](#) on page 8.
- **Is a code displayed on the electronic thermostat?**
Check the LED display on the electronic thermostat. If a code is displayed, refer to ["Diagnostic Features of Electronic Thermostat"](#) on page 8.
- **Are you using more hot water than you think?**
Are outlets (especially the showers) using more hot water than you think? Very often it is not realised the amount of hot water used, particularly when showering. Carefully review the hot water usage. Have your plumber fit a flow control valve to each shower outlet to reduce water usage.
- **Pressure relief valve running**
Is the relief valve discharging too much water? (Refer to ["Pressure Relief Valve Running"](#) on page 9).
- **Thermostat setting**
Ensure the thermostat setting is appropriate. You may choose to have your installer adjust the thermostat upwards to gain additional hot water capacity.



⚠ WARNING: Hotter water increases the risk of scald injury.

- **Water heater size**
Do you have the correct size water heater for your requirements? The sizing guide in the Raypak sales literature and on the Rheem website (www.rheem.com.au) suggests average sizes that may be needed.

WATER HEATER NOT OPERATING



The ignition system may have 'locked out'. To reset the water heater, switch the electrical supply off at the isolating switch, wait five (5) minutes then switch on again. If the water heater fails to light, phone your nearest Rheem Service Department or Accredited Service Agent to arrange for an inspection.

DIAGNOSTIC FEATURES OF ELIWELL ELECTRONIC THERMOSTAT

The alarm condition is always signalled by the buzzer (if present) and by the led of the alarm icon . The alarm signal produced by a faulty room probe is shown as E1 on the instrument display.

Fault conditions should be attended to by your nearest Rheem Service Department or Accredited Service Agent.

LED

Position	Associated function	Status
	Relay 1	ON for relay ON, flashing for delay, disabled protection or activation
	Alarm	ON for an active alarm

BURNER WILL NOT LIGHT

- **Is there gas to the water heater?**
Check the gas isolation valve on the gas supply line is open.
- **Is there a normal gas supply to the rest of the premises?**
Try lighting another gas appliance. If there is no gas call your gas provider.
- **Is the ignition system 'locked out'?**
Try resetting the water heater. Refer to "[Water Heater Not Operating](#)" on page 8.
- **Is the High Limit tripped:**
The manual reset over temperature switch will shut down the water heater in the event of a fault with the temperature control or water flow. When the system water temperature has cooled sufficiently, the red button can be pressed, this will restart the water heater. Should frequent resetting be necessary, call your nearest Rheem Service Department or Accredited Service Agent.

PRESSURE RELIEF VALVE RUNNING

- **Normal Operation**
It is normal and desirable that this valve allows a small quantity of water to escape during the heating cycle. However, if the discharge is deemed excessive (more than 2% of hot water used), there may be another problem.
- **Continuous dribble**
Try gently raising the easing lever on the relief valve for a few seconds (refer to "[Pressure Relief Valve](#)" on page 10). This may dislodge a small particle of foreign matter and clear the fault. Release the lever gently.
- **Steady flows for long period (often at night)**
This may indicate the mains water pressure sometimes rises above the designed pressure of the water heater. Ask your installing plumber to fit a pressure limiting valve.

⚠ WARNING: Never replace the relief valve with one of a pressure rating greater than 850 kPa.

EXPANSION CONTROL VALVE RUNNING

If an expansion control valve is fitted in the cold water line to the water heater (refer to page 17) it may discharge a small quantity of water instead of the pressure relief valve on the water heater. The benefit is that energy is conserved as the discharged water is cooler.

HIGH GAS BILLS

Should you at any time feel your gas account is too high, we suggest you check the following points:

Is the relief valve running excessively? (Refer to "[Pressure Relief Valve Running](#)" on page 9).

Are outlets (especially the showers) using more hot water than you think? (Refer to "[Not Enough Hot Water](#)" on page 8).

Is there a leaking hot water pipe, dripping hot water tap, etc? Even a small leak will waste a surprising quantity of hot water and gas. Replace faulty tap washers, and have your plumber rectify any leaking pipe work.

Consider recent changes to your hot water usage pattern and check if there has been any increase in tariffs since your previous account.

Is there excessive heat loss from the building? Check that there are no large uncovered windows, ceiling insulation is installed and there are no excessive draughts.



IF YOU HAVE CHECKED ALL THE FOREGOING AND STILL BELIEVE YOU NEED ASSISTANCE, PHONE YOUR NEAREST RHEEM SERVICE DEPARTMENT OR ACCREDITED SERVICE AGENT

REGULAR CARE

SERVICE

For efficient operation the water heater should be serviced annually by your nearest Rheem Service Department or Accredited Service Agent. Only genuine replacement parts should be used on this water heater.

⚠ WARNING: Servicing of a gas water heater should only be carried out by qualified personnel.

MINOR SIX MONTH MAINTENANCE

Refer to Service Procedures on page 34

ANNUAL SERVICE

Refer to Service Procedures on page 34

MAJOR FIVE YEAR SERVICE

Refer to Service Procedures on page 34

PRESSURE RELIEF VALVE

This valve is located in the in/out header of the water heater and is essential for its safe operation. It is possible for the valve to release a little water through the drain line during each heating period. This occurs as the water is heated and expands by approximately 1/50 of its volume.

Continuous leakage of water from the valve and its drain line may indicate a problem with the water heater (refer to [“Pressure Relief Valve Running”](#) on page 9).

⚠ Warning: Never block the outlet of this valve or its drain line for any reason.

Operate the easing lever on the pressure relief valve once every six months. **It is very important you raise and lower the lever gently.**

⚠ Warning: Failure to do this may result in the water heater heat exchanger failing.

⚠ Warning: Exercise care to avoid any splashing of water, as water discharged from the drain line will be hot. Stand clear of the drain line's point of discharge when operating the valve's lever.

If water does not flow freely from the drain line when the lever is lifted, then the water heater must be checked. Phone Rheem Service or their nearest Accredited Service Agent to arrange for an inspection.

The pressure relief valve should be checked for performance or replaced at intervals not exceeding 5 years, or more frequently in areas where there is a high incidence of water deposits (refer to [“Water Supplies”](#) on page 35).

EXPANSION CONTROL VALVE

In many areas, including South Australia, Western Australia and scaling water areas, an expansion control valve is fitted to the cold water line to the water heating system. The expansion control valve may discharge a small quantity of water from its drain line during the heating period instead of the pressure relief valve on the water heater.

Operate the easing lever on the expansion control valve once every six months. **It is very important you raise and lower the lever gently.** The expansion control valve should be checked for performance or replaced at intervals not exceeding 5 years, or more frequently in areas where there is a high incidence of water deposits.

STORAGE TANKS (IF FITTED)

Refer to the owners guide and installation instructions supplied with the storage tank for details on regular care required.

INSTALLATION

THIS WATER HEATER IS NOT SUITABLE FOR POOL HEATING

INSTALLATION STANDARDS

The water heater must be installed:

- by a qualified person, and
- in accordance the installation instructions, and
- in compliance with Standards AS/NZS 3500.4, AS 5601 or AS/NZS 5601.1, as applicable under local regulations, and all local codes and regulatory authority requirements.

In New Zealand the installation must also conform with NZS 5261, as applicable under local regulations, and the New Zealand Building Code.

All packaging materials must be removed from the water heater prior to its installation. This includes the removal of the pallet from the underside of the water heater.

WATER HEATER APPLICATION

This water heater is designed for the purpose of heating for potable water or hydronic heating applications. Its use in an application other than this may shorten its life.

If this water heater is to be used where an uninterrupted hot water supply is necessary for the application or business, then there should be redundancy within the hot water system design. This should ensure the continuity of hot water supply in the event that this water heater was to become inoperable for any reason. We recommend you provide advice to the system owner about their needs and building backup redundancy into the hot water supply system.

Check the water heater is suitable for the gas type available. The gas type is marked on the side panel near the gas connection entry and shown on the rating label.

All packaging must be removed from the water heater prior to its installation. The installation kit (including the pressure relief valve) may be supplied inside the water heater casing. This kit must be removed before the water heater is operated.

READ THESE INSTRUCTIONS IN FULL

INSPECTION OF EQUIPMENT

Check the water heater and associated equipment for any damage. **DO NOT INSTALL OR OPERATE ANY WATER HEATER THAT HAS BEEN DAMAGED. ANY ADDITIONAL DAMAGE OR FAULTS CAUSED BY UNAUTHORISED START UP MAY NOT BE COVERED BY WARRANTY.**

WATER HEATER LOCATION

This water heater is supplied for outdoor installation only. For indoor installations the correct indoor conversion kit is required (refer to "[Hood Conversion](#)" on page 15). Whether located outdoor or indoor, the position of the water heater should be chosen with safety and service in mind. Make sure people (particularly children) will not touch the flue outlet. The flue terminal must be clear of obstructions and shrubbery.

Clearance must be allowed for servicing of the water heater. The water heater must be accessible without the use of a ladder or scaffold. Make sure the pressure relief valve lever is accessible and the entire front panel and burner assembly can be removed for service. Remember you may have to remove the entire water heater later for servicing.

You must be able to read the information on the rating label.

The water heater must not be installed in an area with a corrosive atmosphere where chemicals are stored or where aerosol propellants are released. Remember the air may be safe to breathe, but when it goes through a flame, chemical changes take place which may attack the water heater.

The water heater must be mounted on a level fire proof base such as a concrete slab, concrete plinth, steel plate etc. Water heaters must NOT be installed on carpeting.

The front of the water heater must not be obstructed by any gas or water piping, electrical conduits, etc.

SAFE TRAY

Where damage to property can occur in the event of the water heater leaking, the water heater must be installed in a safe tray. Construction, installation and draining of a safe tray must comply with AS/NZS 3500.4 and all local codes and regulatory authority requirements. AS/NZS 3500.4 also has particular requirements when a safe tray must be installed.

FIRE RESISTANT MATERIALS

Fire resistant materials should comply with the requirements of AS 5601 Appendix C. If in doubt, seek advice from your material supplier or your local regulator.

INDOOR INSTALLATION

The correct draft diverter must be fixed to the top of the water heater (Refer to “Hood Conversion” on page 15) and connected to a properly constructed flue, to discharge the combustion products outside the building. The flue must be self supporting and not impose a load on the water heater. Use a slip joint or similar to allow for disconnection and to enable the water heater top panel and draft diverter to be removed for servicing. There must be a vertical rise of 600 mm from the draught diverter before changing direction. The flue design and installation must comply with AS 5601.

NOTE: Reduction of the flue diameter or alteration to the draft diverter may void the water heater warranty.

The water heater is to be installed at ground or floor level and must stand vertically upright. There are also special requirements in AS 5601 for water heaters installed in a garage, an enclosed space and other locations. Remember all local authorities have regulations about putting water heaters into roof spaces.

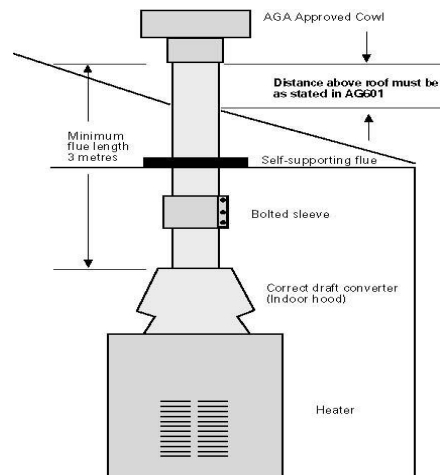

CLEARANCES (INDOOR INSTALLATIONS)

The distances set out in the following table should be observed.

Minimum Clearances from:	Non-Combustible materials (mm)	Combustible Materials (mm)
Rear	150	500
Water Side	600	600
Front	750	750
Non Water Side	150	500
Ceiling	1200	1200

The normal water heater design is with the water pipe entry from the left hand side. For servicing purposes allow at least 750mm in front of the water heater for burner tray removal.

COMBUSTION / VENTILATION AIR

Indoor model water heaters must be installed in a protective enclosure or properly constructed plant room with adequate ventilation in accordance with AS 5601.

Ideally ventilation shall be via two permanent openings DIRECTLY to outside, one at an upper level and one at low level.

Where the air is sourced DIRECTLY from outside the minimum free area required for each opening is provided in the table opposite. Where the ventilation is by an alternate method refer to AS 5601 for ventilation calculations.

NOTE: The minimum dimension of any opening shall be 6mm

⚠ WARNING! Air supply to the area where the water heater is installed must not be affected by mechanical exhaust vents such as kitchen or bathroom fans, spa blowers, etc. Mechanical exhaust vents may create a negative pressure in the area where the water heater is installed and can become a hazard by asphyxiation, explosion or fire.

OUTDOOR INSTALLATION

For servicing allow at least 750 mm in front of the water heater for burner removal and 450 mm on the water connections side for heat exchanger servicing.

The water heater must NOT be installed inside any roofed structure or under eaves, roof overhangs, or pool decks.

When installing the water heater on a raised base, the base material MUST be solid and filled in (e.g. if steel mesh decking is used, a suitable plate material must be installed to fill in the perforations) to prevent excessive drafts entering the water heater from underneath.

The following distances extracted from the Australian Gas Installations Standard AS 5601 must be observed:

- At least 500 mm between the top of the flue terminal and the eaves.
- At least 1 500 mm horizontally between the flue terminal and the edge of any opening into the building, measured horizontally.
- At least 500 mm between the flue terminal and a return wall or external corner, measured horizontally along the wall.
- At least 1 500 mm below any openable window.
- At least 500 mm between the flue terminal and a fence, wall or other obstruction facing the terminal.

HIGH WIND CONDITIONS

In areas where high winds frequently occur, it may be necessary to:

- Locate the water heater a minimum of one (1) metre away from high vertical walls.
- Install a wind break to protect the water heater is from the prevailing winds.
- Replace the standard flue terminal with a HIGH WIND top (at extra cost).

Model	Total area (cm ²)
200	585
280	825
350	1035
430	1275

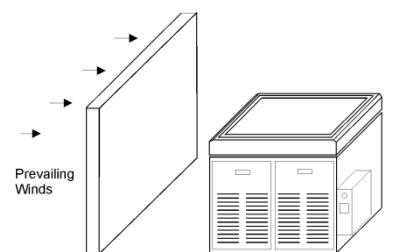
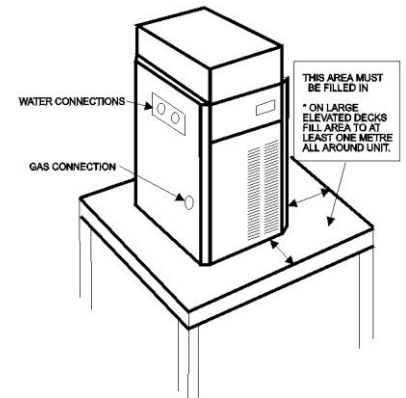

COLD WATER SUPPLY

Water Heating Applications

Where the cold water supply pressure exceeds that shown in the table below, an approved pressure limiting valve is required and should be fitted as shown in the installation diagram (refer to diagram on page 17).

Mechanical/Process Heating Applications

A cold water feed regulator (Pressure Reducing Valve) should be installed on the cold water make up line. The minimum water pressure should be as shown in the table below. Backflow prevention in accordance with AS/NZS 3500.1 may be required.

Pressure Specifications		
Operation Type	On/Off	Modulating
Relief Valve Setting		
Water Heating (kPa)	850 (700) ¹	850 (700) ^{1 3}
Mechanical Heating (kPa)	-	310
Expansion Control Valve (ECV²) Setting		
Water Heating (kPa)	700 (550) ¹	700 (550) ^{1 3}
Mechanical Heating (kPa)	-	-
Minimum Supply Pressure		
System water temperatures up to 65°C (kPa)	70	70
System water temperatures above 65°C (kPa)	120	120
Maximum Supply Pressure		
with ECV ² fitted		
Water Heating (kPa)	680 (550) ¹	680 (550) ^{1 3}
Mechanical Heating (kPa)	-	240
without ECV ² fitted		
Water Heating (kPa)	550 (450) ¹	550 (450) ^{1 3}
Mechanical Heating (kPa)	-	-

¹ Figures in brackets are to be used if a stainless steel storage tank is utilised in the system.

² Expansion control valve is not supplied with the water heater.

³ An 850kPa relief valve can be fitted to modulating water heaters when used in water heating applications.

TANK WATER SUPPLY

If the water heater is supplied with water from a tank supply and a pressure pump system is not installed then the height to the bottom of the supply tank must be as specified in the table opposite.

Minimum Tank Height	
System water temperatures up to 65°C	7 metres
System water temperatures above 65°C	12 metres

HOT WATER DELIVERY (WATER HEATING APPLICATIONS)

This water heater can deliver water at temperatures which can cause scalding.

It is necessary and we recommend that a temperature limiting device be fitted between the water heating system and the hot water outlets in any ablution and public areas such as bathrooms, ensuites or public amenities, to reduce the risk of scalding. The installing plumber may have a legal obligation to ensure the installation of this water heater meets the delivery water temperature requirements of AS/NZS 3500.4 so that scalding water temperatures are not delivered to a bathroom, ensuite, or other ablution or public area.

Where a temperature limiting device is installed adjacent to the hot water storage tanks, the cold water line to the temperature limiting device can be branched off the cold water line either before or after the isolation valve, pressure limiting valve and non return valve to the storage tanks. If an expansion control valve is required, it must always be installed after the non return valve and be the last valve prior to the water heating system.

If a pressure limiting valve is installed on the cold water line to the water heating system and the cold water line to a temperature limiting device branches off before this valve or from another cold water line in the premises, then a pressure limiting valve of an equal pressure setting may be required prior to the temperature limiting device.

REDUCING HEAT LOSSES (WATER HEATING APPLICATIONS)

The cold water line to and the hot water line from the storage cylinder must be insulated in accordance with the requirements of AS/NZS 3500.4. The insulation must be weatherproof and UV resistant if exposed.

Keep temperature settings down. Lower temperatures reduce heat losses and prolong storage cylinder life. Do not set the controlling electronic thermostat above 70°C unless it is necessary. A time clock to control the electrical supply can be used to switch off the water heater during hours or days when it is not in use.

HOOD CONVERSION

To convert a water heater from an outdoor configuration to an Indoor or High Wind Top configuration, proceed as follows:

1. Remove the flue terminal (outdoor hood) from the water heater leaving the jacket top in place.

Place the stack adaptor over the flue collector and secure into place with self tapping screws.

Fit the draft diverter over the spigot and sit squarely on the stack adaptor. Secure in place using self tapping screws.

(Indoor installations only) Install and connect the secondary flue to the draft diverter in accordance with the requirements of AS 5601.

NOTE: For High Wind Top conversion follow steps 1 to 3 and assess whether tie downs for the High Wind Cowl are required.

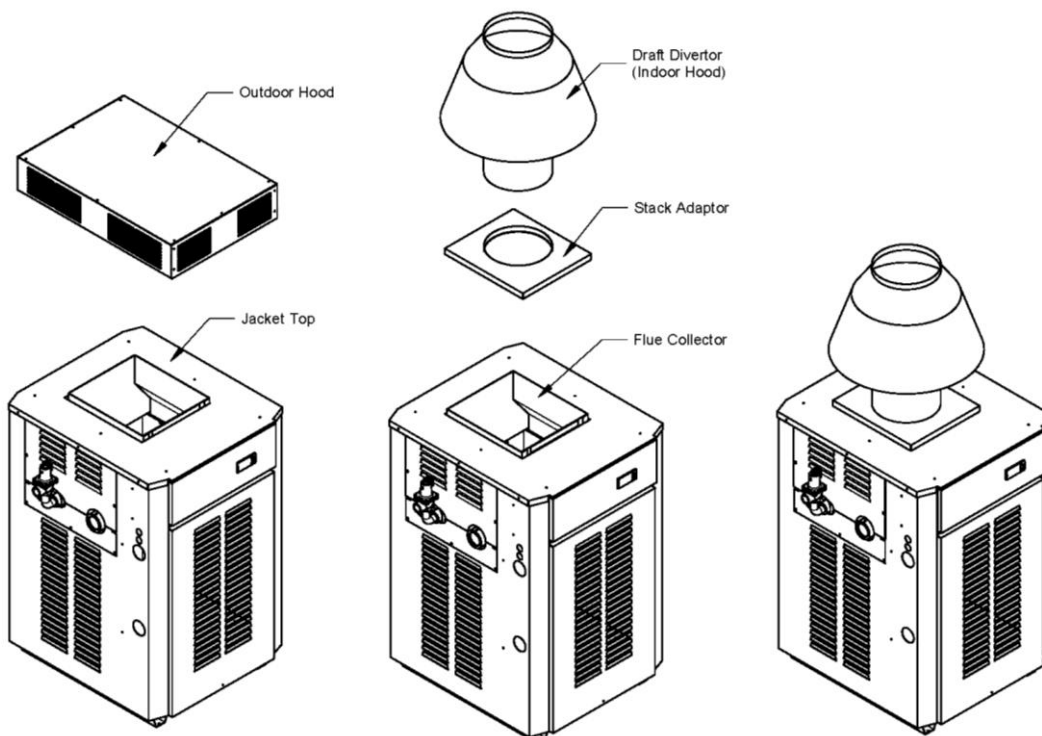

DIMENSIONS AND TECHNICAL DATA

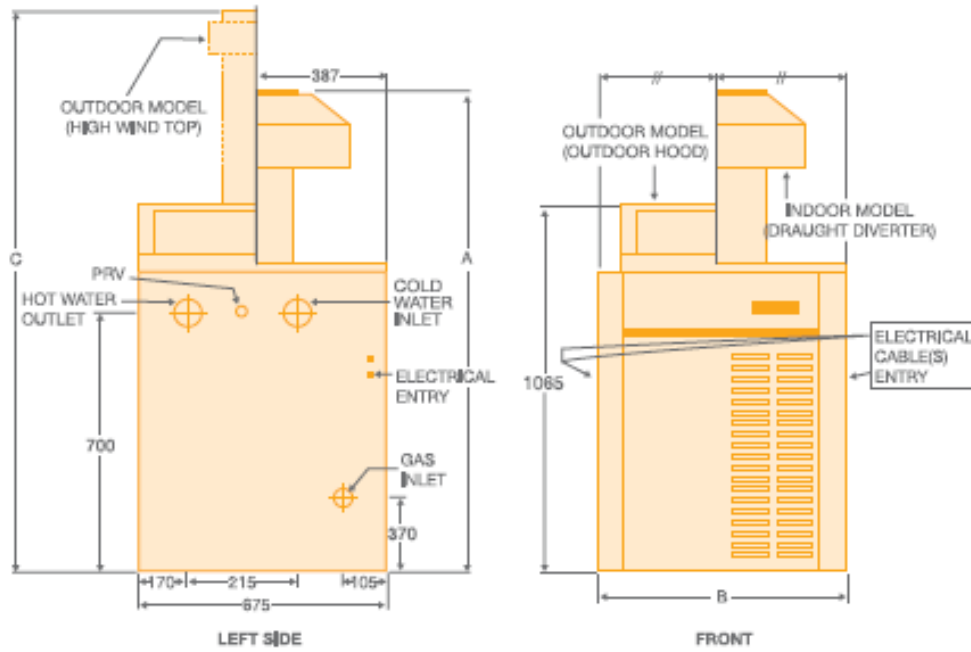

		200	280	350	430	
Natural Gas	Input (MJ/h)	196	278	343	420	
	Output (kW)	44	62	76	94	
Propane Gas	Input (MJ/h)	185	261	323	396	
	Output (kW)	41	58	72	88	
Electrical Rating 240 V 50 Hz	Power (W)	50	50	50	50	
	Current (A)	0.21	0.21	0.21	0.21	
Weight empty	Kg	91	93	103	107	
Flue Connection	mm	175	205	225	255	
Dimensions	A	mm	1625	1715	1715	1805
	B	mm	465	570	655	745
	C	mm	1955	2240	2035	2145

CONNECTIONS – PLUMBING

IMPORTANT: When installing a new water heater to an old or existing system, it is a requirement that the system and its equipment be thoroughly inspected and if necessary, drained and flushed with clean fresh water, before the new water heater is connected. Failure to do this may cause blockages and/or damage to the water heater which is not covered by warranty.

IF THERE IS ANY DOUBT ABOUT THE SYSTEM, DRAIN AND FLUSH AS A PRECAUTION.

CONNECTION SIZES

- Inlet water connection: RC1½/40
- Outlet water connection: RC1½/40
- Relief valve connection: RC¾/20
- Gas inlet (On/Off Models): RC¾/20
- Gas Inlet (Modulating Models): RC1/25

All plumbing work must be carried out by a qualified person and in accordance with the National Plumbing Standard AS/NZS 3500.4 and local authority requirements.

All gas work must be carried out by a qualified person and in accordance with the Australian Gas Installations Standard AS 5601 and local authority requirements.

WATER INLET AND OUTLET

All pipe work must be cleared of foreign matter before connection and purged before attempting to operate the water heater. All olive compression fittings must use brass or copper olives. Use thread sealing tape or approved thread sealant on all fittings.

An isolation valve and non-return valve must be installed on the cold water line to the water heating system. An acceptable arrangement is shown in the diagram opposite for a water heating application.

A disconnection union must always be provided at the inlet and outlet on the water heater to allow for disconnection of the water heater.

Do not reduce the pipe work size and water heater water connections without allowing for friction loss which will occur. Low water flow will cause damage to the water heater and system components.

GAS INLET

The gas connection is made to the inlet of the gas control (On/Off Models) or pressure regulator (Modulating Models). The pipe work must be cleared of foreign matter before connection and purged before attempting to light the water heater. An isolation valve and disconnection union must be used to allow servicing and removal of the water heater.

Refer to the Gas Installations Standard AS 5601 for the correct method of sizing the gas supply pipe to the water heater.

⚠ WARNING: Before pressure testing the gas supply system always isolate and disconnect the water heater after the isolating cock to prevent the risk of serious damage to the gas control or pressure regulator. Warranty does not cover damage of any nature resulting from failure to observe this precaution. Refer to rating label for gas types and pressures.

Ensure the gas line is also purged at the union to the gas control or pressure regulator. If this procedure is not followed, a retry lockout may result on initial start up.

CAUTION: Care is necessary when tightening fittings into the gas control or pressure regulator. The gas control or pressure regulator casting may crack if the fittings are over tightened. Cracked castings are not covered under warranty. Damaged gas controls and pressure regulators must be replaced.

PIPE SIZES

The pipe sizing for water heating and mechanical heating systems should be carried out by persons competent to do so, choosing the most suitable pipe size for each individual application. Reference to the technical specifications of the water heater and local regulatory authority requirements must be made.

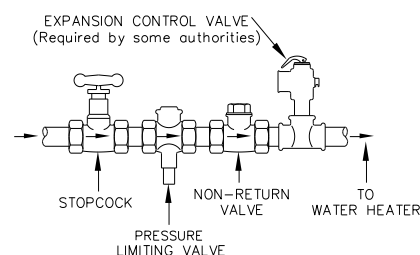

The table below provides indicative pipe and pump sizes for typical installations

Model	Pump		Branch Size		Minimum Manifold Header Size Required (mm)			
	UPS Series	Speed	inches	mm	1 Unit	2 Units	3 Units	4 Units
200	20-60B	3	1	25	25	32	40	50
280	20-60B	3	1¼	32	32	32	50	50
350	32-80B	2	1¼	32	32	40	50	50
430	32-80B	3	1¼	32	32	40	50	65

PUMP SELECTION

In order to obtain the best possible water flow in the system a correctly sized pump must be installed. Refer to the Flow Rate and Pressure Drop table below and allow for the system head pressure when sizing the pump.

The pump selected should provide a 10 to 20°C temperature difference between the water heater inlet and outlet when the water heater is at full fire.

Mechanical heating systems with multiple zones may require additional pump(s) refer to ‘Multi Pump Options’ on page 24.

WATER FLOW RATE AND PRESSURE DROP						
Model	10°C Rise		15°C Rise		20°C Rise	
	l/sec	kPa	l/sec	kPa	l/sec	kPa
200	1.04	3	0.69	3	0.52	3
280	1.47	8	0.98	4	0.74	3
350	1.82	13	1.22	6	0.91	3
430	2.24	17	1.49	8	1.12	4

PRESSURE RELIEF VALVE

The pressure relief valve and elbow are shipped in a plastic bag inside the water heater. The pressure relief valve must be fitted before the water heater is operated.

Fit the elbow supplied in the plastic bag to the ¾” connection on the inlet/outlet header then screw the relief valve onto the other end of the elbow.

Seal the treads using Teflon tape, never hemp. A drain line must be installed in accordance with AS/NZS 3500.4 to carry the discharge from the valve to a suitable discharge point.

Relief Valve Pressure Rating	
On/Off Models	850 kPa (125 psi)
Modulating Models	310 kPa (45 psi)

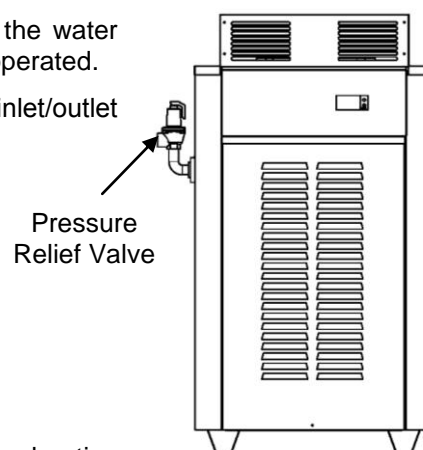

When the water heater is connected to a storage cylinder for water heating applications, a correctly sized and pressure rated TPR valve MUST be fitted to the storage cylinder.

NOTE: Where a modulating water heater is used in a water heating application it will be necessary to replace the 310 kPa relief valve provided with the water heater with one rated at 850 kPa.

RELIEF VALVE DRAIN

A copper drain line must be fitted to the relief valve to carry the discharge clear of the water heater. Connect the drain line to the relief valve using a disconnection union. The pipe work from the relief valve to the drain should be as short as possible and fall all the way from the water heater with no restrictions. It should have no more than three right angle bends in it. Use DN20 pipe.

The outlet of the drain line must be in such a position that flow out of the pipe can be easily seen (refer to AS/NZS 3500.4) - but arranged so hot water discharge will not cause injury, damage or nuisance. The drain line must discharge at an outlet or air break not more than 9 metres from the relief valve.

In locations where water pipes are prone to freezing, the drain line must be insulated and not exceed 300 mm in length. In this instance, the drain line is to discharge into a tundish through an air gap of between 75 mm and 150 mm.

⚠ WARNING: The pressure relief valve on this water heater may discharge high temperature water under certain conditions, it is strongly recommended the pipe work downstream of the relief valve be capable of carrying water exceeding 93°C. Failure to observe this precaution may result in damage to pipe work and property.

MECHANICAL HEATING

All high points of a mechanical heating system should be provided with manual bleed points or fitted with automatic air vents. The design of the system must be such that the water heater is provided with adequate water flow and pressure at all times (refer to 'Pump Selection' on page 18). On radiator or heating systems where thermostatic valves will vary the water flow a suitable by-pass valve must be installed to maintain the correct flow rate.

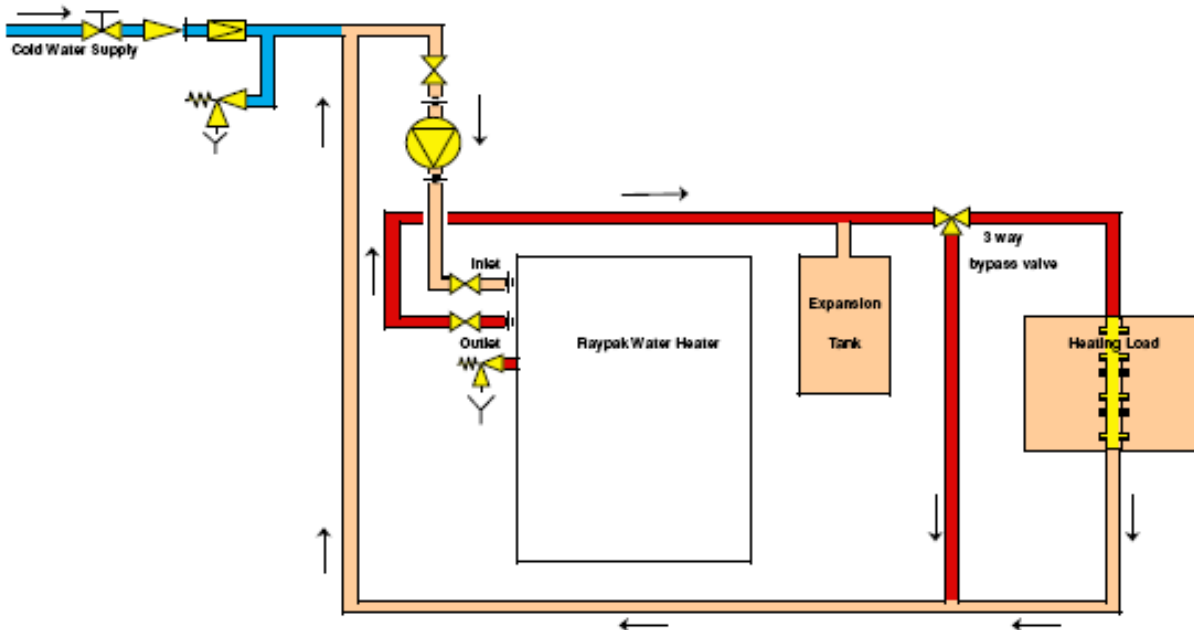

Typical Mechanical Heating Installation

WATER HEATING

Where the water heater is required for hot water applications, the heater **MUST** be used in conjunction with a hot water storage tank, manufactured in compliance with AS 3498 under a current Watermark license. To inhibit the growth of Legionella bacteria, the tankstat controlling the temperature of the stored water must not be set below 60°C.

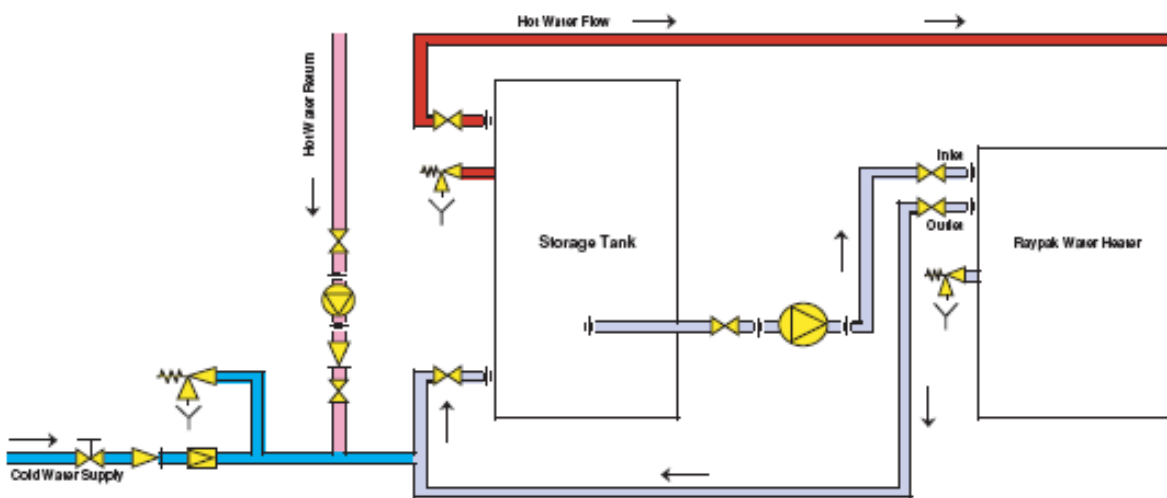

Typical Water Heating Installation

CONNECTIONS – ELECTRICAL

All electrical work and permanent wiring must be carried out by a qualified person and in accordance with the Wiring Rules AS/NZS 3000 and local authority requirements.

The water heater is supplied with a 1.8 metre lead and plug and requires a 240 V 50 Hz general purpose outlet (GPO) to be located within 1.0 metre of the installation. NOTE: For outdoor installations the GPO must be weatherproof. The GPO must be clear of the flue exhaust, draining water, gas supply pipe and water connections.

The water heater must be properly earthed and the installation of a Residual Current Device (RCD) is recommended for added electrical safety

CAUTION: DO NOT LOCATE CABLES IN FRONT OF OR UNDERNEATH THE BURNER.

Where conduit is mounted to the water heater a 10mm air gap must be maintained from the water heater casing to eliminate possible overheating. DO NOT locate conduits or cables where they will obstruct or restrict removal of panels, access doors etc.

The water heater must NOT be able to operate without the pump running.

The water heater and pump may be supplied from the same electrical circuit, alternatively the 240 volt supply to the water heater may be provided via auxiliary contacts of the pump contactor or relay (if fitted).

Where additional control wiring is connected to the water heater, which is not isolated by the GPO, a suitable warning label must be affixed to the water heater identifying the isolation point for that particular wiring (e.g. by circuit breaker or fuse number and switchboard identification number or location).

THERMOSTAT SETTING

The thermostat is adjustable from 20°C to 80°C. For reasons of safety and economy, we recommend that the thermostat is set at the lowest temperature that will provide sufficient hot water. Discuss the thermostat setting requirements with the householder or responsible officer. Refer to ["Temperature Control"](#) on page 30.

INTERMITTENT PUMP OPERATION

For applications utilising intermittent pump operation an optional pump run on timer kit, part number 56076873, must be fitted to the water heater to prevent nuisance tripping of the high limit thermostat due to heat build up in the heat exchanger. The timer should be set to allow the pump to operate for at least ten (10) minutes.

EXTERNAL CONTROLS

The water heater can be wired for use with an external flow switch, remote control thermostat or a remote time switch. To connect an external control to the water heater it is necessary to remove the bridging wire between terminals 1 and 2 of the water heater terminal block and connect the external control across these two terminals (refer to the diagram opposite and to the wiring diagrams on pages 22 to 23).

Where an external thermostat is utilised the water heater thermostat should be adjusted to a temperature higher than the setting on the remote thermostat (Refer to ["Temperature Control"](#) on page 30).

WIRING A POWER FLUED SYSTEM TO THE WATER HEATER

An indoor model can be wired to a power flued system. A power flued system must be designed by a qualified person to suit the particular installation. The power flue system must be interlocked with the water heater(s) to prevent the water heater(s) from operating if the power flue is not working.

Where multiple water heaters are connected to a power flue, the control system must be designed so that any of the water heaters can activate the fan in the flue and none of the burners can come on until the flow in the flue has been established.

To connect a power flue to the water heater it is necessary to remove the bridging wire between terminals 3 and 4 of the water heater terminal block and connect the wiring to the power flue across these two terminals (refer to the diagram opposite and to the wiring diagrams on pages 22 and 23)

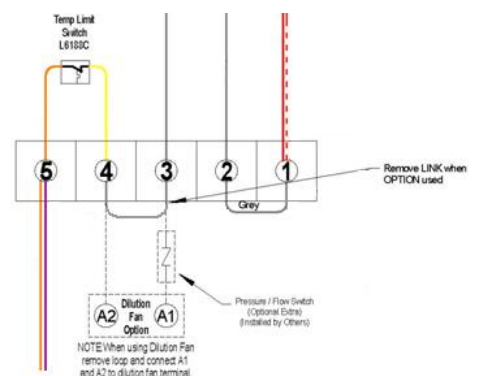
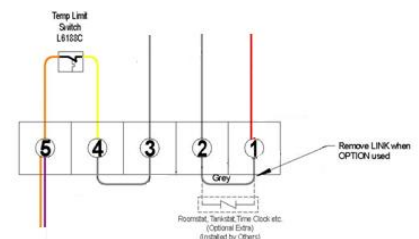

BUILDING MANAGEMENT SYSTEM (BMS)

For applications requiring connection to a building management system, an optional BMS kit, part number 56076884, suitable for modulating models ONLY must be fitted to the water heater to provide 'run' and 'fail' status.

On/Off models cannot be connected to a building management system.

CONTROL PANEL ACCESS

To access the electrical enclosure:

- Remove the Philips head screw from the bottom of the front panel.
- Remove the front panel by lifting up and out.
- Remove 4 x Philips head screws (2 on each side) from the control panel.
- Hinge the control panel down. NOTE: The control panel has tabs fitted to support it on the water heater in the open position.

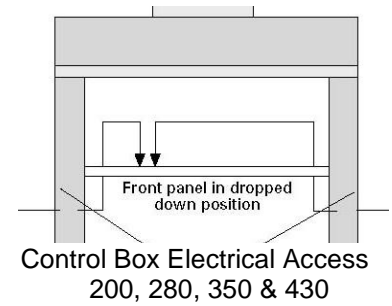

WIRING DIAGRAM - ON/OFF MODELS

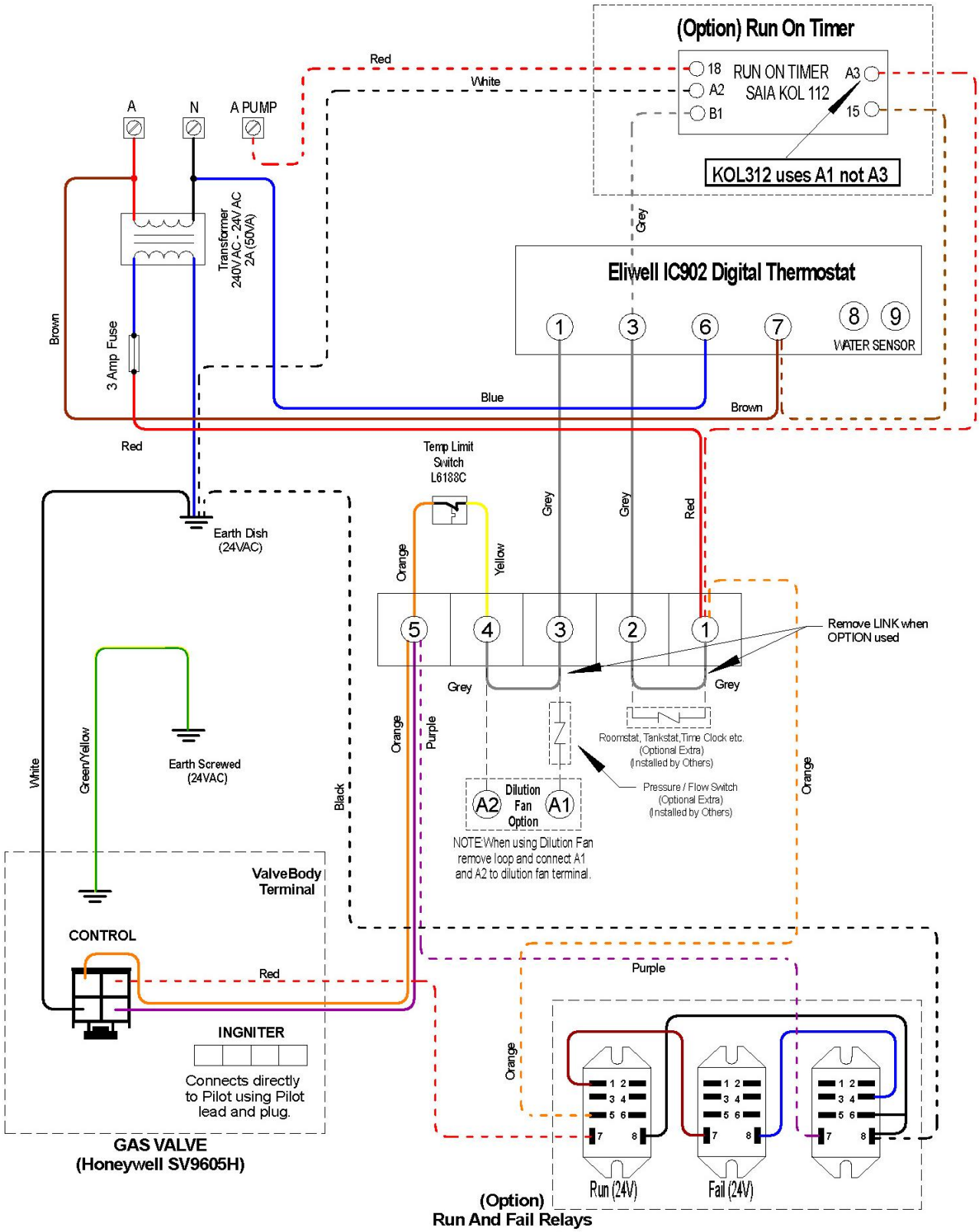

WIRING DIAGRAM - MODULATING MODELS

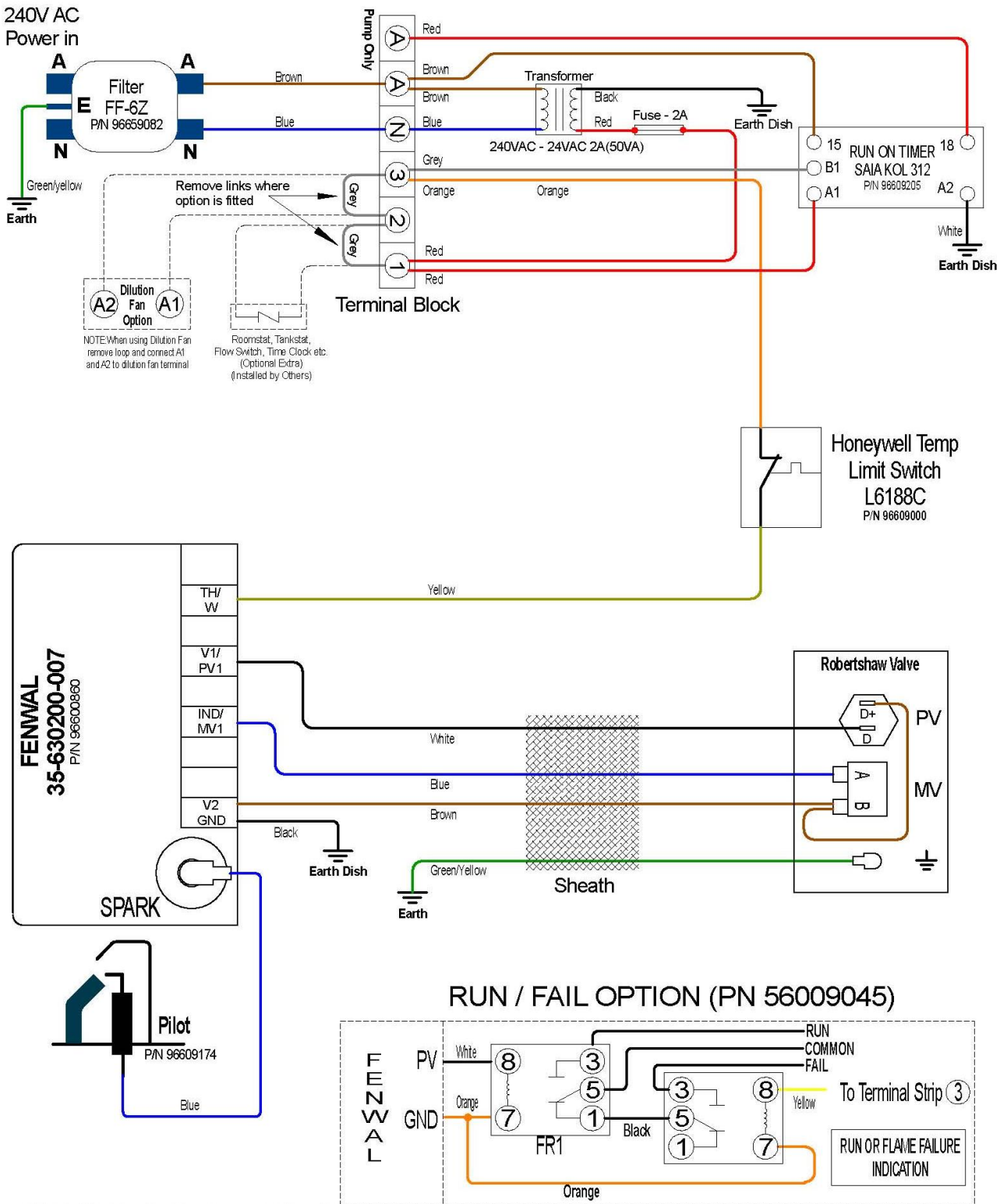

MULTI PUMP OPTION - MECHANICAL HEATING SYSTEMS

NOTE: When connecting additional controls the relays and timers etc must be located in an additional enclosure NOT fitted within the water heater. For outdoor installations the enclosure MUST be weatherproof.

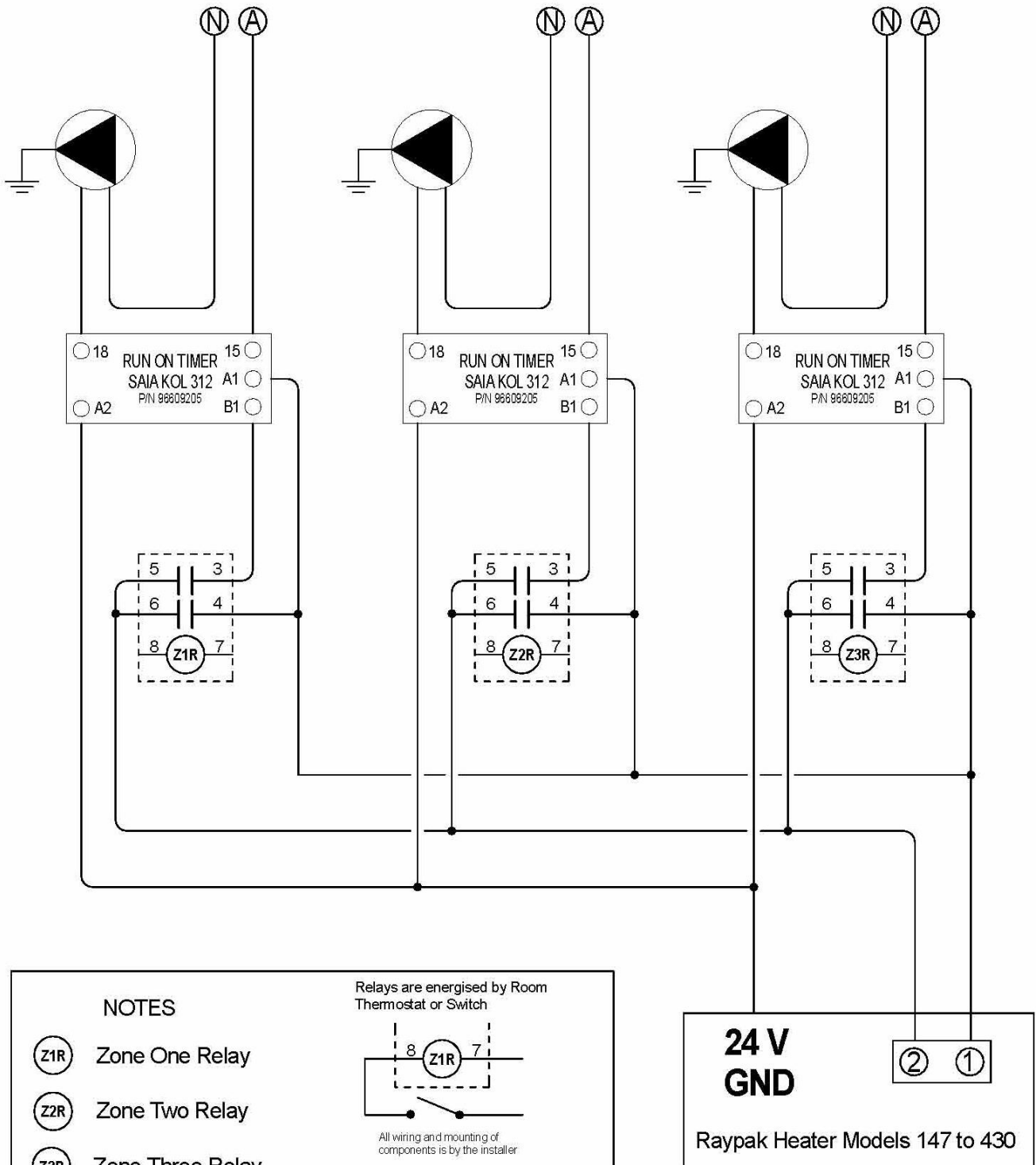

NOTES

- Zone One Relay
- Zone Two Relay
- Zone Three Relay
- Water Pump

Relays are energised by Room Thermostat or Switch

All wiring and mounting of components is by the installer

BE CAREFUL!
There is no limit to the amount of Zones. However, make sure that the boiler transformer has enough capacity to power the relays and Run on Timer (Economasters). Another transformer will be necessary if that is the case.

LOCATION OF CONTROLS

THERMOSTAT

On/Off Models

On/Off type water heaters are fitted with an Eliwell IC902 electronic thermostat (Item 1 in the diagram) with its sensor located in the inlet side of the water heater header. This type of control is used where the system load is constant (e.g. hot water supplied from a storage tank or in floor slab heating).

NOTE: If the water heater is connected to a storage tank with a tank thermostat fitted, the water heater thermostat should be set slightly higher than the tank thermostat setting

Modulating Models

For Modulating Models, temperature control is performed by the gas control which has its sensor located in the outlet side of the water heater header (see below).

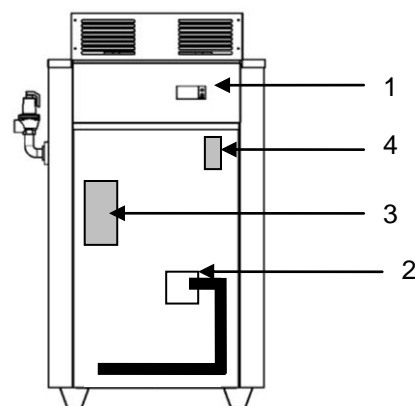

200 - 430

GAS CONTROL (ITEM 2 IN THE DIAGRAM)

On/Off Models

On/Off type water heaters are fitted with a Honeywell SV9605 smart valve. This gas control incorporates the ignition electronics and provides the gas supply to the pilot and main burners.

Modulating Models

Modulating type water heaters are fitted with a Robertshaw 7000 series modulating gas control. The gas control modulates the gas rate to match the required heating load. Modulating water heaters are usually installed on a heating system with radiators or a fan coil.

RATING LABEL (ITEM 3 IN THE DIAGRAM)

Details the model number, serial number, gas type, burner pressure, water pressure and electrical specifications of the water heater are given on this label.

HIGH LIMIT (ITEM 4 IN THE DIAGRAM)

A manual reset over temperature switch which will shut down the water heater in the event of a fault with the temperature control or water flow. When the system water temperature has cooled sufficiently the high limit can be reset by pressing the red button.

SAFETY PRECAUTIONS



Ceramic fire tile refractories are used in Raypak water heaters. Refractories must be treated with care because they can be harmful by inhalation and irritating to the skin, eyes and respiratory system.

DURING FIRST FIRING OF THE WATER HEATER

- Fumes and smoke may be produced.
- Avoid breathing fumes and ventilate the area to clear.
- Production of smoke should cease within 30 minutes.

WHEN HANDLING

- Minimise airborne dust.
- Wear an approved mask or respirator.
- Avoid any contact with the skin and eyes.
- Wear suitable loose-fitting, long-sleeved clothing or disposable overalls.
- Wear gloves and eye protection.
- Consult Occupational Health and Safety Authorities for any further information.

AFTER HANDLING

- Rinse any exposed skin areas with clean water.
- Wash work clothing separately.

REMOVAL OF USED PRODUCT

- Follow the precautions as detailed in the section 'WHEN HANDLING' above, over-exposure to dust formed after service may cause respiratory disease as cristobalite, a form of crystalline silica, may be formed above 900 degrees Celsius.
- Seal used product in a disposable bag and dispose of via normal garbage collection methods.

Consult Occupational Health and Safety Authorities for further information regarding removal of used ceramic fibre lining.

COMMISSIONING

COMMISSIONING MUST ONLY BE UNDERTAKEN BY AN APPROPRIATELY LICENSED PERSON WHO IS FAMILIAR WITH SAFE COMMISSIONING PROCEDURES.



Ceramic fire tile refractories are used in Raypak water heaters. Refractories must be treated with care because they can be harmful by inhalation and irritating to the skin, eyes and respiratory system.

Refer to “[Safety Precautions](#)” on page 26 for the precautions to be taken when the water heater is first operated.

PRE-START CHECKS

- Ensure all packaging materials have been removed from the water heater.
- Conduct a visual inspection of the water heater and equipment for any damage or installation problems and report as necessary.
- Ensure that the water heater is clean and the surrounding area is clear of all combustible and flammable materials.
- Remove all liquids and chemicals from the plant room and check that combustion air openings are not obstructed.
- Test ALL gas connections for leaks, using soapy water. **NOT A NAKED FLAME**
- Ensure the water heater is filled with water (refer to “[To Fill the Water Heater](#)” on page 28).
- Check that the correct power supply is available and the circulation pump is supplied from the same electrical circuit as the water heater.
- Check that the ventilation to the plant room complies with the requirements, of AS 5601 and local authority regulations.
- If mechanical ventilation or power fluing is provided, check the operation of the fan(s) and interlocks.
- Check that the flue complies with the appropriate regulations and is fitted with an approved cowl.
- Ensure that the main gas isolation valve is closed.

OPERATIONAL CHECKS

- Turn on the water heater and circulation pump and verify the flow switch operation - if fitted (refer to “[To Turn on the Water Heater](#)” on page 28).
- Test the operation of the water heater with no gas flow to confirm its operation up to lockout stage, then turn off the power.
- Open the gas isolation valve and switch on power to the water heater.
- With the main burner lit and at high fire, check the inlet gas pressure (refer to “[Gas Inlet Pressure](#)” on page 29).
- Check the water heater gas train and components for gas leaks using soapy water. **NOT A NAKED FLAME**
- Set the burner gas pressure to that shown on the rating label (refer to “[Gas Pressure Adjustment](#)” on page 29).
- Make a visual check of the burners. The flame should be blue with a well-defined pattern. A yellow or floating flame indicates restricted air openings or incorrect burner pressure setting.
- Verify that the high limit is operating and set correctly (refer to “[High Limit Adjustment](#)” on page 33).
- Check that the flue on an indoor installation is drawing correctly.
- Check operation of the water pressure relief valve.
- It is normal for the water heater to produce some smoke and possibly condensation for the first thirty (30) minutes of operation from new (refer to “[Safety Precautions](#)” on page 26).

⚠ WARNING: Upon completion of the installation and commissioning of the water heater, leave this guide with the householder or a responsible officer. **DO NOT** leave this guide inside of the cover of the water heater, as it may interfere with the safe operation of the water heater or ignite when the water heater is turned on.

Explain to the householder or a responsible officer the functions and operation of the water heater.

OPERATING THE WATER HEATER

FOR YOUR SAFETY READ BEFORE LIGHTING

TO FILL THE WATER HEATER

Water Heating Applications

- Open all of the hot water tap(s) in the building (don't forget the showers) and supply cock(s) and valve(s) in the system.
- Open the isolation valves fully on the cold, flow / return and hot water branches to the storage tank(s) installed in a bank.
- Open the cold water isolation valve on the cold water line to the storage tank(s).
Air will be forced out of the taps.
- Close each tap as water flows freely from it.
- Check the pipe work for leaks.

Mechanical/Process Heating Applications

- If a header tank is fitted, ensure it is filled with water.
- Open the isolation valve on the inlet line to the water heater.
- Bleed air from the system at all high points to ensure that the entire system is filled with water.
- Check the pipe work for leaks.

TO TURN ON THE WATER HEATER

⚠ WARNING! If you smell gas do not attempt to turn on the water heater.

The power supply to the water heater must not be switched on until the system is filled with water.

- Fill the system with water (refer to ["To Fill the Water Heater"](#) on page 28)
- Open the gas isolation valve fully at the inlet to the water heater.
- Plug in the power supply cord at the power outlet.
- Switch on the electrical supply at the power outlet to the water heater.

NOTE: If the water heater is correctly installed, this will also activate the circulating pump.

The water heater will operate automatically when a call for heat occurs.

TO TURN OFF THE WATER HEATER

If it is necessary to turn off the water heater on completion of the installation, such as on a building site or where the premises is vacant, then:

- Switch off the electrical supply at the power outlet to the water heater
NOTE: If the water heater is correctly installed, this will also shut down the circulating pump.
- Close the gas isolation valve at the inlet to the water heater.
- Close the cold water isolation valve at the inlet to the water heater.
- Close the isolation valves on the cold and hot water branches to shut down an individual water heater in a bank (water heating applications only).

TO RESET THE WATER HEATER

If the system water temperature is abnormally low, the ignition system may have locked out. The ignition system can be reset as follows:

- Turn the power to the water heater off.
- Wait five (5) minutes.
- Turn the power to the water heater on.

If the water heater still fails to operate, call your nearest Rheem Service Department or Accredited Service Agent to arrange for an inspection.

GAS INLET PRESSURE

IMPORTANT – CHECK the gas supply pressure at the inlet to the water heater with the water heater and all other gas burning appliances in the premises operating (burners alight). The minimum gas supply pressures are:

Natural Gas - 1.13 kPa

Propane - 2.75 kPa

If this minimum cannot be achieved, it may indicate the meter or the gas line to the water heater is undersized. It is important to ensure that an adequate gas supply pressure is available to the water heater when other gas burning appliances, on the same gas supply, are operating.

GAS PRESSURE ADJUSTMENT

On/Off Models

To adjust the burner pressure on a water heater with the Honeywell Smart Valve, proceed as follows:

- Remove the gas control cover.
- Remove the screw and washer from the outlet pressure tap.
- Attach a manometer to the outlet pressure tap.
- Remove the cap from the pressure regulator adjuster.
- With the main burner operating, adjust the pressure regulator (clockwise to increase or anti-clockwise to decrease) to achieve the burner pressure as specified on the rating label (refer to “[Location of Controls](#)” on page 25).
- Turn off the water heater.
- Replace the cap on the pressure regulator adjuster.
- Disconnect the manometer and replace the pressure tap screw and washer.
- Check for gas leaks, using soapy water.
- Replace the gas control cover.

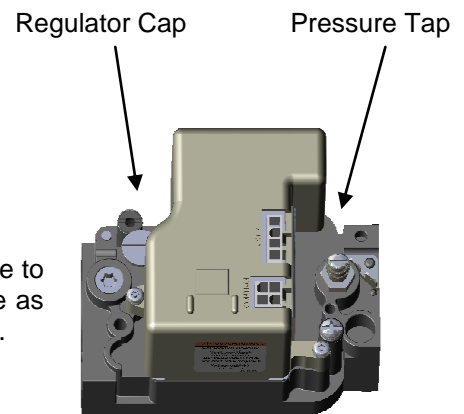

Modulating Models

To adjust the burner pressure on a water heater with the Robertshaw 7000 Series modulating gas control, proceed as follows:

- Remove the gas control cover.
- Remove the screw and washer from the outlet pressure tap on the gas control.
- Attach a manometer to the outlet pressure tap.
- Remove the cap from the Jeavons gas pressure regulator.
- Operate the main burner at high fire, This can usually be achieved by turning the temperature control to the ‘HI’ position. Refer to “[Temperature Control](#)” on page 33.
- Adjust the pressure regulator (clockwise to increase or anti-clockwise to decrease) to achieve the burner pressure as specified on the rating label (refer to “[Location of Controls](#)” on page 25).
- Turn off the water heater.
- Replace the cap on the pressure regulator adjuster.
- Disconnect the manometer and replace the pressure tap screw and washer.
- Check for gas leaks, using soapy water.
- Replace the gas control cover.

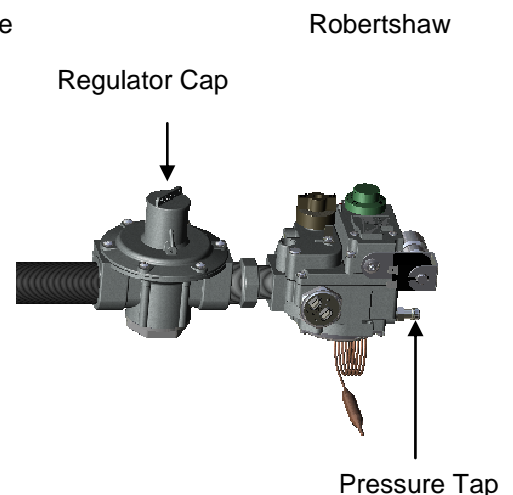

TEMPERATURE CONTROL

HOTTER WATER INCREASES THE RISK OF SCALD INJURY.





This water heater can deliver water at temperatures which can cause scalding.

Water heating applications: It is necessary and we recommend that a temperature limiting device be fitted between the water heating system and the hot water outlets in any ablution and public areas such as bathrooms, ensuites or public amenities, to reduce the risk of scalding. The installing plumber may have a legal obligation to ensure the installation of this water heater meets the delivery water temperature requirements of AS/NZS 3500.4 so that scalding water temperatures are not delivered to a bathroom, ensuite, or other ablution or public area.

THERMOSTAT ADJUSTMENT

On/Off models (Eliwell Thermostat)

KEYS AND MENUS

UP key		Scrolls through the menu items Increases the values
DOWN key		Scrolls through the menu items Decreases the values
FNC key		ESC function (exit)
SET key		Accesses the setpoint Accesses the menus Confirms the commands



The instrument has two main menus: the “Machine Status” and “Programming” menu.

ACCESSING AND USING MENUS

The instrument is programmed by menus. To access a menu, press and quickly release the “SET” key (“Machine status menu”) or press the “SET” key for over 5 seconds (“Programming” menu). To access the contents of each folder, indicated by the relevant label, just press the “SET” key once. You can now scroll through the contents of each folder, modify it or use its functions. If you do not use the keyboard for over 15 seconds (time-out) or if you press the “FNC” key once, the last value shown on the display is confirmed and you return to the previous screen mask.

MACHINE STATUS MENU

To access the “Machine Status” menu, press and quickly release the “SET” key. The “Set” folder label appears. To view the Setpoint value, press the “SET” key again. The Setpoint value appears on the display. To change the Setpoint value, use the “UP” and “DOWN” keys within 15 seconds. If the parameter is LOC = y the Setpoint cannot be changed.

PROGRAMMING MENU

To enter the “Programming” menu, press the “SET” key for more than 5 seconds. If specified, the access PASSWORD will be requested, (parameter “PA1”), and the label of the first folder will follow. To scroll through the other folders, use the “UP” and “DOWN” keys. To enter the folder, press “SET”. The label of the first visible parameter appears. To scroll through the other parameters, use the “UP” and “DOWN” keys. To change the parameter, press and release “SET” then set the desired value with the “UP” and “DOWN” keys, and confirm with the “SET” key, to move to the next parameter.

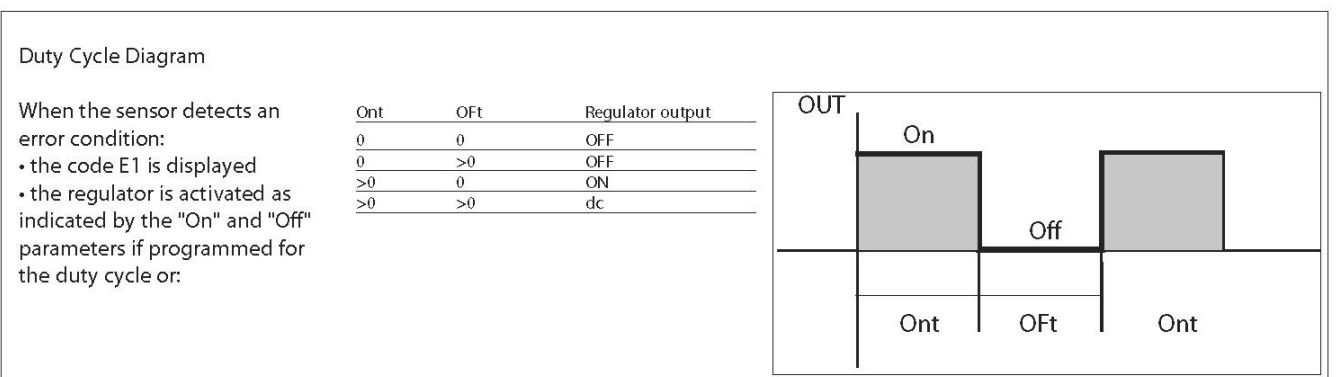
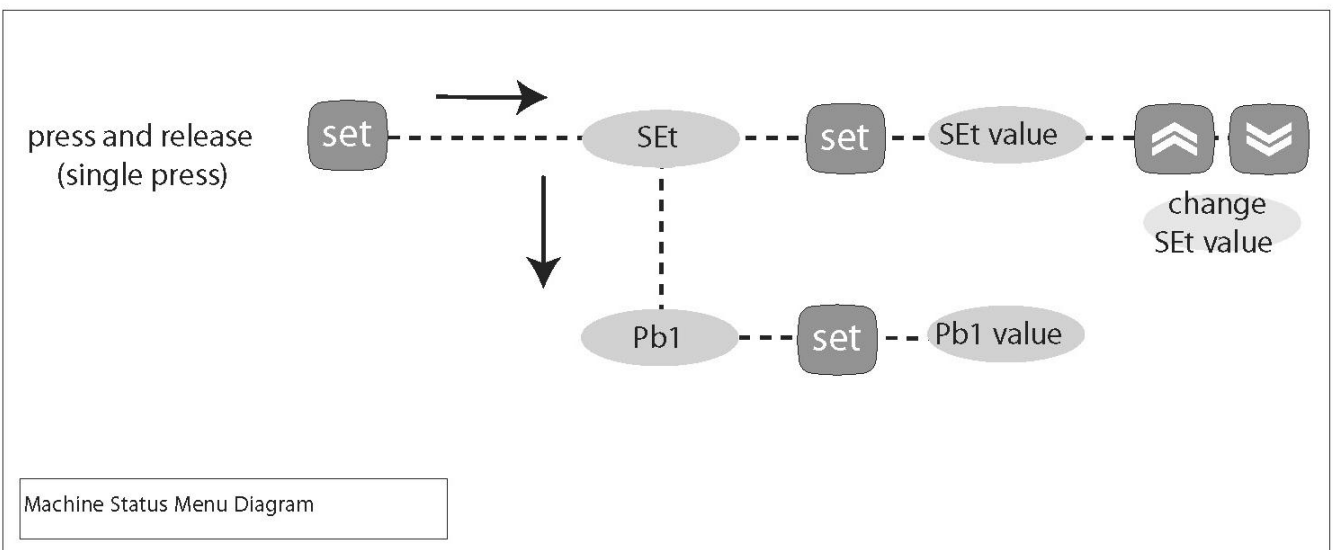
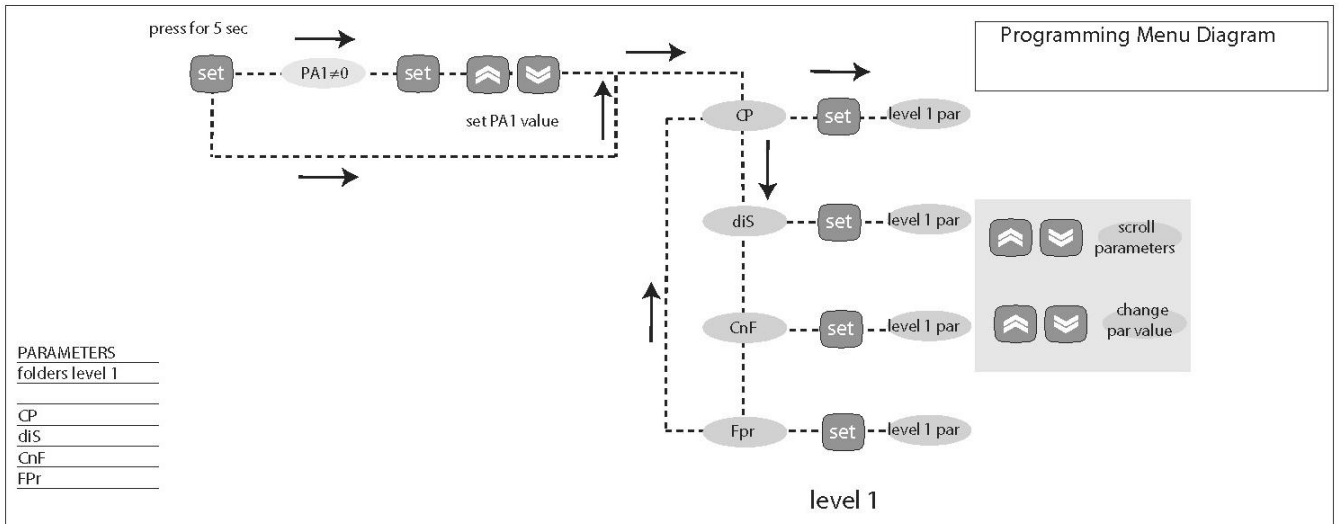

WIRING

1 - 2	N.C. regulator relay output	OUT
1 - 3	N.O. regulator relay output	OUT
6 - 7	Power supply	• model 230V: 3 VA max. • model 12V: 1,5 VA max.
8 - 9	Sensor input (thermostat)	Pb1
A	TTL input for Copy Card	

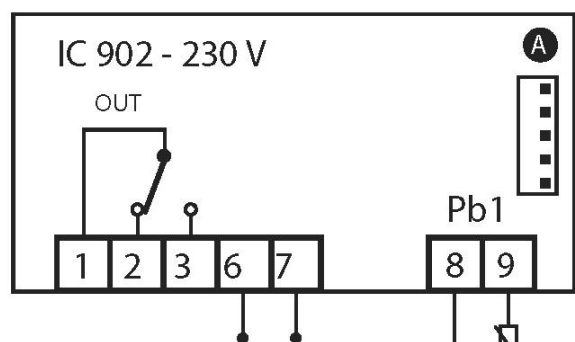

Programming Parameters

Level	Parameter	Unit	Minimum	Maximum	Raypak Setting
CP	Set point differential (diF)	°C/°F	0.1	30	2
	Set point Maximum (HSE)	°C/°F	-55	302	80
	Set point Minimum (LSE)	°C/°F	-55	302	20
	Heat / Cool mode (HC)	H/C			H
	(Ont)				
	(Oft)				
	Delay, time relay on (dOn)	sec	0	250	0
	Delay, time relay off (dOF)	min	0	250	0
dis	(dbi)	min	0	250	0
	Delay time at start up (OdO)	min	0	250	0
	Key pad lock (LOC)	y/n			n
	Password (PA1)	num	0	250	0
	View decimal point (ndt)	y/n			
CnF	Calibration offset (CA1)	°C°F	-12	12	0
	Units°C or°F (dro)	0/1			0
	Probe type selection (HOO)	0/1			1
Fpr	Device version (reL)				
	Reserved (tAB)				
Fpr	Upload to copy card (UL)				
	Download from copy card (dL)				

MODULATING MODELS (ROBERTSHAW 7000DSTRDHHC MODULATING VALVE)

The water temperature is selected by turning the temperature adjustment knob on the Robertshaw 7000 Series modulating valve to a number which corresponds to the table opposite. The gas control cover must be removed to gain access to the adjustment knob and must be replaced after the temperature adjustment has been made.



Dial No	Temp °C
Lo	43
1	49
2	55
3	62
4	68
5	74
6	80
7	86
8	93
HI	99

HIGH-LIMIT THERMOSTAT ADJUSTMENT

A Honeywell high limit thermostat is used on both On/Off and Modulating water heaters (refer to "[Location of Controls](#)" on page 25). The thermostat has a capillary style temperature sensor located in a well (pocket) fitted in the outlet header and senses the temperature of the water leaving the water heater.

The high limit temperature setting is adjusted by removing the front cover (loosen one Phillips-head screw) and turning the adjuster.

The high limit is reset by pressing the red button on the front of the thermostat. It may be necessary to allow the system water temperature to cool sufficiently before the high limit can be reset.

In general, the high limit should be set approximately 15°C above the operating temperature, however the following maximum limits must be observed:

- **Water Heating Applications:** 90°C maximum.
- **Mechanical/Process Heating Applications:** 99°C maximum for vented systems and 90°C maximum for unvented systems.

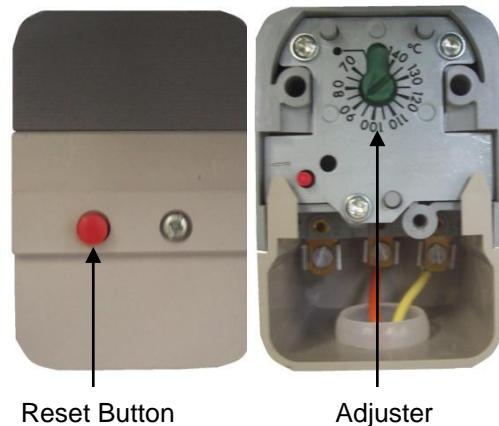

SERVICE PROCEDURES

ONLY AN AUTHORISED PERSON MAY REPAIR OR SERVICE A GAS APPLIANCE.



Ceramic fire tile refractories are used in Raypak water heaters. Refractories must be treated with care because they can be harmful by inhalation and irritating to the skin, eyes and respiratory system.

Refer to “[Safety precautions](#)” on page 26 for the precautions to be taken when servicing the water heater.

SIX MONTHLY SERVICE PROCEDURE

1. Isolate power to the water heater.
2. Operate the pressure relief valve (PRV) manually to check that the drain is clear and the valve reseals.
3. Remove burner access door and header access panels
4. Visually inspect combustion chamber area for build up of debris and clean if necessary.
5. Check the water heater thoroughly for any damage.
6. Check the heat exchanger and water seal areas for leaks and signs of sooting.
7. Check air vents and louvers, clean as required.
8. Restore power and check operation of the ignition system and all safety devices.
9. Check operation and calibration of all temperature control devices.
10. Perform a leak test on all gas unions using soapy water solution.
11. Check and monitor the operation of the water heater for at least ten (10) minutes.
 - With the burner lit, make a visual check of the main burner and pilot flame. Yellow flames indicate some restriction of the combustion air openings or incorrect burner gas pressure setting.
 - A bright orange, luminous flame is not normal and can cause sooting under prolonged operation.
12. Refit burner access door and header access panels.
13. Clean and remove any dust and debris from the water heater and its immediate area.

ANNUAL SERVICE PROCEDURE

1. Conduct the Six Monthly Service Procedure detailed above PLUS
2. Isolate gas, electricity and water supplies.
3. Disconnect and remove the burner tray.
4. Check igniter electrode and flame rod - clean and re-align if required.
5. Check main burner injectors – clean if required.
6. Clean burner bars.
7. Inspect external area of heat exchanger, clean fins and baffles.
8. Refit the burner tray and reconnect the gas train.
9. Restore gas, electricity and water supplies.
10. Perform a leak test on the gas train using soapy water solution.
11. Check burner pressure - adjust if required. Refer to “[Gas Pressure Adjustment](#)” on page 29
12. Refit all panels and the burner access door.

During the maintenance procedures detailed above all damaged or faulty components should be reported to the householder or responsible officer and arrangements made to effect immediate repairs.

DO NOT return the water heater to service where an unsafe condition exists.

⚠ WARNING! Operation of the water heater when faulty or incorrectly adjusted will result in rapid and severe damage which is not covered by warranty.

WATER SUPPLIES

This water heater must be installed in accordance with this advice to be covered by the Raypak warranty.

This water heater is manufactured to suit the water conditions of most public reticulated water supplies. However, there are some known water supplies which can have detrimental effects on the water heater and its operation and/or life expectancy. If you are unsure of your water quality, you may be able to obtain information from your local water supply authority. This water heater should only be connected to a water supply which complies with these guidelines for the Raypak warranty to apply.

SATURATION INDEX

The saturation index (SI) is used as a measure of the water's corrosive or scaling properties.

In a corrosive water supply, the water can attack copper parts and cause them to fail. Where the saturation index is less than -1.0 , the water is very corrosive and warranty does not apply to a copper heat exchanger in a continuous flow water heater.

Where the saturation index exceeds $+0.40$, the water is very scaling. An expansion control valve must be fitted on the cold water line after the non-return valve to protect and for the Raypak warranty to apply to the pressure relief valve.

In a scaling water supply calcium carbonate is deposited out of the water onto any hot metallic surface. Where the saturation index exceeds $+0.80$, warranty does not apply to a copper heat exchanger in a continuous flow water heater.

Water which is scaling may be treated with a water softening device to reduce the saturation index of the water.

Refer to the [Saturation Index chart](#) on page 35.

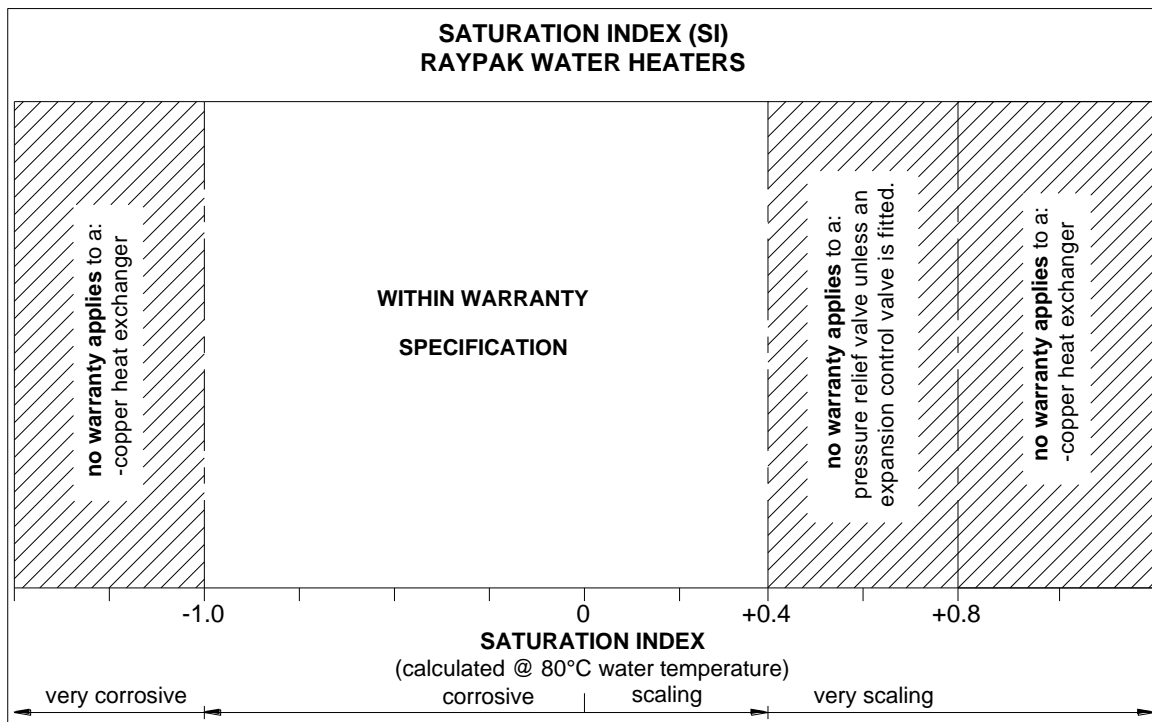

CHANGE OF WATER SUPPLY

The changing or alternating from one water supply to another can have a detrimental effect on the operation and / or life expectation of a water heater cylinder and a temperature pressure relief valve.

Where there is a changeover from one water supply to another, e.g. a rainwater tank supply, bore water supply, desalinated water supply, public reticulated water supply or water brought in from another supply, then water chemistry information should be sought from the supplier or it should be tested to ensure the water supply meets the requirements given in these guidelines for the Raypak warranty to apply.

This page is intentionally blank.

This page is intentionally blank.

This page is intentionally blank.

WARRANTY

RAYPAK WATER HEATER WARRANTY – AUSTRALIA ONLY

RAYPAK WATER HEATER MODELS B0200, B0280, B0350, B0430

1. THE RHEEM WARRANTY – GENERAL

- 1.1 This warranty is given by Rheem Australia Pty Limited ABN 21 098 823 511 of 1 Alan Street, Rydalmere New South Wales.
- 1.2 Rheem offer a trained and qualified national service network who will repair or replace components at the address of the water heater subject to the terms of the Rheem warranty. Rheem Service, in addition can provide preventative maintenance and advice on the operation of your water heater. The Rheem Service contact number is available 7 days a week on 131031 with Service personnel available to take your call from 8am to 8pm daily (hours subject to change).
- 1.3 For details about this warranty, you can contact us on 131031 or by email at warrantyenquiry@rheem.com.au (not for service bookings).
- 1.4 The terms of this warranty are set out in section 2 and apply to water heaters manufactured after 1st January 2012.
- 1.5 If a subsequent version of this warranty is published, the terms of that warranty will apply to water heaters manufactured after the date specified in the subsequent version.

2. TERMS OF THE RHEEM WARRANTY AND EXCLUSIONS TO IT

- 2.1 The decision of whether to repair or replace a faulty component is at Rheem's sole discretion.
- 2.2 If you require a call out and we find that the fault is not covered by the Rheem warranty, you are responsible for our standard call out charge. If you wish to have the relevant component repaired or replaced by Rheem, that service will be at your cost.
- 2.3 Where a failed component or cylinder is replaced under this warranty, the balance of the original warranty period will remain effective. The replacement does not carry a new Rheem warranty.
- 2.4 Where the water heater is installed outside the boundaries of a metropolitan area as defined by Rheem or further than 25 km from either a regional Rheem branch office or an Accredited Rheem Service Agent's office, the cost of transport, insurance and travelling between the nearest branch office or Rheem Accredited Service Agent's office and the installed site shall be the owner's responsibility.
- 2.5 Where the water heater is installed in a position that does not allow safe or ready access, the cost of that access, including the cost of additional materials handling and/or safety equipment, shall be the owner's responsibility. In other words, the cost of dismantling or removing cupboards, doors or walls and the cost of any special equipment to bring the water heater to floor or ground level or to a serviceable position is not covered by this warranty.
- 2.6 This warranty only applies to the original and genuine Rheem water heater in its original installed location and any genuine Rheem replacement parts.
- 2.7 The Rheem warranty does not cover faults that are a result of:
 - a) Accidental damage to the water heater or any component (for example: (i) Acts of God such as floods, storms, fires, lightning strikes and the like; and (ii) third party acts or omissions).
 - b) Misuse or abnormal use of the water heater.
 - c) Installation not in accordance with the Owner's Guide and Installation Instructions or with relevant statutory and local requirements in the State or Territory in which the water heater is installed.
 - d) Connection at any time to a water supply that does not comply with the water supply guidelines as outlined in the Owner's Guide and Installation Instructions.
 - e) Repairs, attempts to repair or modifications to the water heater by a person other than Rheem Service or a Rheem Accredited Service Agent.
 - f) Faulty plumbing or faulty power supply.
 - g) Failure to maintain the water heater in accordance with the Owner's Guide and Installation Instructions.
 - h) Transport damage.
 - i) Fair wear and tear from adverse conditions (for example, corrosion).
 - j) Cosmetic defects.
- 2.8 Subject to any statutory provisions to the contrary, this warranty excludes any and all claims for damage to furniture, carpet, walls, foundations or any other consequential loss either directly or indirectly due to leakage from the water heater, or due to leakage from fittings and/ or pipe work of metal, plastic or other materials caused by water temperature, workmanship or other modes of failure.
- 2.9 If the water heater is not sized to supply the hot water demand in accordance with the guidelines in the Rheem water heater literature, any resultant fault will not be covered by the Rheem warranty.

3. WHAT IS COVERED BY THE RHEEM WARRANTY FOR THE WATER HEATERS DETAILED IN THIS DOCUMENT

3.1 Rheem will repair or replace a faulty component of your water heater if it fails to operate in accordance with its specifications as follows:

What components are covered	The period in which the fault must appear in order to be covered	What coverage you receive
All components	Year 1	Repair and/or replacement of the faulty component, free of charge, including labour.
Heat Exchanger / Tube Bundle	Years 2 to 5	Replacement heat exchanger or tube bundle, free of charge. Installation and repair labour costs are the responsibility of the owner.

4. ENTITLEMENT TO MAKE A CLAIM UNDER THIS WARRANTY

- 4.1 To be entitled to make a claim under this warranty you need to:
- Be the owner of the water heater or have consent of the owner to act on their behalf.
 - Contact Rheem Service without undue delay after detection of the defect and, in any event, within the applicable warranty period.
- 4.2 You are **not** entitled to make a claim under this warranty if your water heater:
- Does not have its original serial numbers or rating labels.
 - Is not installed in Australia.

5. HOW TO MAKE A CLAIM UNDER THIS WARRANTY

- 5.1 If you wish to make a claim under this warranty, you need to:
- Contact Rheem on 131031 and provide owner's details, address of the water heater, a contact number and date of installation of the water heater or if that's unavailable, the date of manufacture and serial number (from the rating label on the water heater).
 - Rheem will arrange for the water heater to be tested and assessed on-site.
 - If Rheem determines that you have a valid warranty claim, Rheem will repair or replace the water heater in accordance with this warranty.
- 5.2 Any expenses incurred in the making of a claim under this warranty will be borne by you.

6. THE AUSTRALIAN CONSUMER LAW

- 6.1 Our goods come with guarantees that cannot be excluded under the *Australian Consumer Law*. You are entitled to a replacement or refund for a major failure and for compensation for any other reasonably foreseeable loss or damage. You are also entitled to have the goods repaired or replaced if the goods fail to be of acceptable quality and the failure does not amount to a major failure.
- 6.2 The Rheem warranty (set out above) is in addition to any rights and remedies that you may have under the *Australian Consumer Law*.

RHEEM AUSTRALIA PTY LTD, A.B.N. 21 098 823 511, www.rheem.com.au

RAYPAK AUSTRALIA PTY LTD A.B.N. 65 078 743 414, www.raypak.com.au

For Service Telephone 131 031 AUSTRALIA or 0800 657 335 NEW ZEALAND