



# Installation and Owner's Manual

## IMPORTANT INFORMATION

Read This Document First

On completion, sign and leave with owner

# **airo**heat®

## Heat Pump Water Heater

Model: D2FHG4HW0C



Installation Details

Owner's Information

Warranty

For advice, repairs and service, call:

1300 365 115 (Australia)

0800 729 389 (New Zealand)



Carefully remove all packaging and transit protection from the heater before installation. Dispose of the packaging responsibly using re-cycling facilities where they exist.

This appliance must be installed by a licensed tradesperson and in accordance with:

- Manufacturer's instructions
- AS/NZS 3500.4 "National Plumbing & Drainage Code Hot Water Supply Systems – Acceptable Solutions"
- Adherence to local authority and OH&S regulations
- Victorian PIC Requirements

Specifications and materials may change without notice.

Effective for Airoheat® water heaters manufactured and sold after 1st January 2012.

H4120 025941 Rev. B



## Contents

Welcome To Dux Hot Water	1
Rough-In Diagram	2
Installation Instructions	3
Installation Declaration	12
Owner's Manual	13
Troubleshooting	18
System Maintenance	20
Safety Information	21
Warranty	22
Other Information	25



## Welcome To Dux Hot Water

Your decision to purchase a Dux Hot Water system will reward you for many years to come.

Since 1915, the Dux range has seen continuous research and development, resulting in many breakthroughs in the efficiency, reliability and longevity of hot water systems.

Dux water heaters are manufactured in Australia in a state-of-the-art facility, using a Quality Endorsed Company production system.

This is your assurance that you have purchased the highest quality water heater available, one that will provide continuous hot water for all your needs – safely, economically, and for many years to come.

To be upfront about it, we want Dux to be your brand of choice. So you can depend on us to provide more than just a hot water system.

You can rely on Dux products and choose them with confidence. We'll make sure you have the information, the quality and the innovation you're looking for, including the latest energy-saving alternatives. If you should ever have a problem – and we'll bet you won't – you'll find that we're easy to get hold of, friendly to talk to and quick to act. Our service is all about providing anything you need as soon as you need it.

Go with Dux and you'll have a dependable, economical, efficient hot water system designed to perform well, year after year. And that's a promise.





# Rough-In Diagram

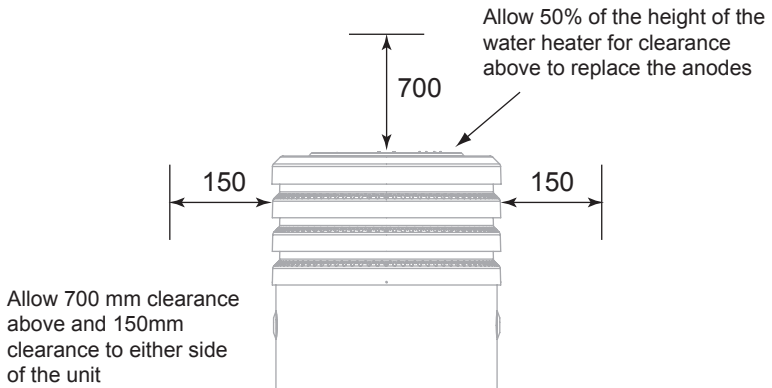
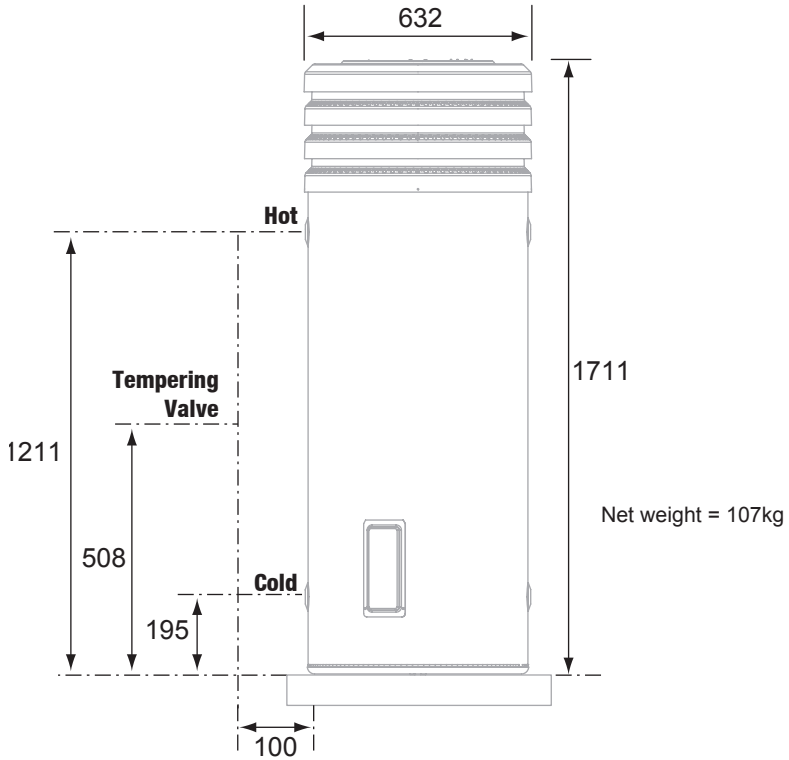



# Installation Instructions

## Regulatory Requirements

This water heater must be installed by a licensed tradesperson, and in accordance with:

- AS/NZS3500.4.2 “National Plumbing and Drainage Code Hot Water Supply Systems – Acceptable Solutions”.
- AS/NZS3000.
- Local authority regulations.
- Outside Australia and New Zealand, please refer to local plumbing and building codes and regulations.
- Notice to Victorian customers from the Victorian Plumbing Industry Commission – this water heater must be installed by a licensed person as required by the *Victorian Building Act* (1993). Only a licensed person will give you a compliance certificate, showing that the work complies with all the relevant Standards and only a licensed person will have insurance protecting their workmanship for 6 years.



**Note: This water heater and heat pump components are not suitable for pool heating.**

## Specifications

The net weight of the heat pump is 107kg.

Dimensions are shown in the rough-in diagram in this manual.



# Installation Instructions

## Transport and Handling



**Critical: When moving the unit, it must be close to vertical at all times.**

**When using a trolley to move the unit, ensure it is not tilted more than 45° from the vertical.**

**Non-compliance will void warranty and severely affect product performance and operation.**

Never tilt unit more than 45° from vertical

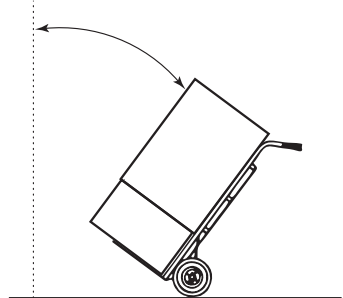

## Step 1

- Arrive at site and conduct a safety audit.
- Safety audits can also be known as Work Method Statements (WMS) or Job Site Analysis (JSA).
- Park your vehicle as close as allowable to your installation.
- Unload all materials in a safe manner.
- Position all materials in a convenient position near the work area.
- The existing tank (if applicable) should be drained and removed in a responsible manner.



**Note: Do not commence a job where the risks cannot be controlled.**



**Note: Do not drain on to grass or garden beds.**



# Installation Instructions

## Placement of New Tank

### Step 2

- The water heater **must** be installed outdoors, close to the most frequently used hot water outlet.
- Optimum installation location is on the warmest side of house.
- The location must consider noise impact on living areas. Avoid positioning near bedrooms or neighbours' bedrooms. Although the running noise level is very low (51 dB(A)) it can be expected that the heat pump will run during the night.
- Adequate access must be available to the relief valve and anodes.
- Safely position the new unit on a level surface in accordance with all plumbing and building regulations.
- A properly drained overflow tray must be used where property damage could occur from water spillage. (See AS/NZS3500.4.2 for further details.)

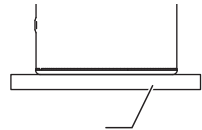
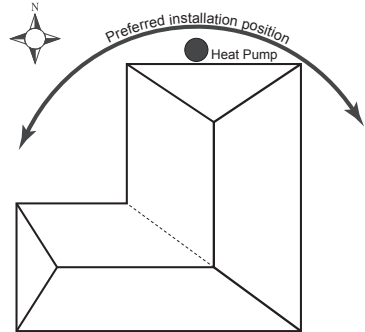

Install a plinth under the water heater where the water heater is subjected to wet conditions



**Note: The warranty does not cover consequential damage due to leakage of the water heater.**



# Installation Instructions

- Allow 200m<sup>3</sup> of free space surrounding the unit. This provides clear ambient airflow assisting the product's performance.
- The area must also be clear of debris such as leaves and tree branches.
- Allow 700 mm clearance above and 150mm clearance to either side of the unit as shown in the Rough-In Diagram on page 2.
- Ensure there are no obstructions placed on top of the unit.
- Total clearance required from ground to install unit is approximately 2410mm.

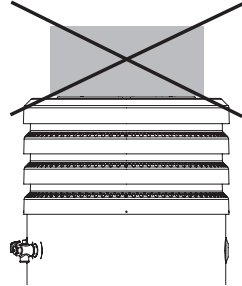

## Plumbing Connections

### Step 3

- Refer to the Rough-In Diagram on page 2 for detailed information on position of plumbing.
- An approved isolating valve, non-return valve, line strainer (optional but recommended), and union must be fitted between the supply main and the RP $\frac{3}{4}$ /20 socket in the water heater.
- All fittings must be approved by the relevant installation Authority.

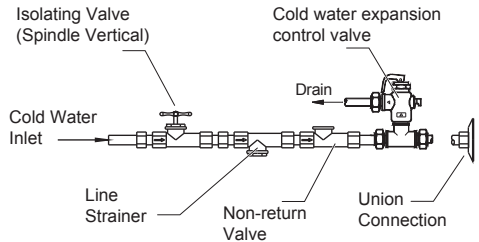

**Note: For S.A. and W.A., it is a state requirement that a cold water expansion control valve be fitted on the cold water supply line between the non-return valve and the water heater.**





## Installation Instructions

- This water heater is designed for direct connection to water supply pressures of no greater than **800kPa**.
- Where the mains pressure can exceed or fluctuate beyond 800kPa, a pressure limiting device (complying with AS1357) must be fitted.

### PTR Valve

- Connect the supplied PTR valve into the top socket marked "RELIEF VALVE" and discharge according to plumbing regulations.
- PTR Valves for the unit are rated at **1000kpa**.
- The drain line from this valve must run in a continuously downward direction with the discharge end left permanently open to atmosphere.



**Warning: A separate drain line must be run for this relief valve. It is not permitted to couple drain lines from relief valves into a single common drain line.**

- The PTR Valve is not intended to enable connection of the water heater to supplementary energy sources such as solar panels or slow combustion stoves (refer AS/ NZS 3500.4.2 for guidance on these types of installations)



# Installation Instructions

## Cold and Hot Water Connections

- Connect the cold water pipe to the storage tank, according to local regulations and the Plumbing Code.
- The hot water line should be connected to the hot water outlet.

## Tempering Valve

- A tempering valve is **mandatory**.
- Ensure it is commissioned correctly. Incorrect commissioning can lead to a lack of hot water.
- We recommend using an **orange top** Reliance brand tempering valve.

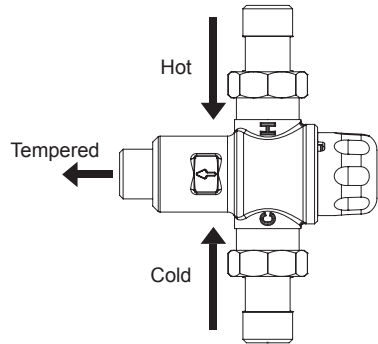

## Condensation Drain Line

- A condensation drain line is required to be fitted to carry discharge clear of water heater.
- Condensate drain line should **not** be connected to the PTR Valve drain line but can exit to the same point.

## Insulation

- It is recommended that all hot water lines are insulated with high temperature, UV resistant 13mm closed cell insulation.



# Installation Instructions

## Electrical Connections

### Step 4

---

- A properly authorised electrical contractor must connect the unit.
- The unit is rated at 10 amps (2 core and earth) so the power mains supplying the unit must have a 10 amp minimum double pole circuit breaker fitted.
- The electrical connection must comply with local supply authority regulations and AS3000.
- The unit must be connected to:
  - CONTINUOUS TARIFF, single phase 240 volt AC supply.
  - Tariff 33 (QLD only), single phase 240 volt AC supply.
- The mains AC supply connection is located under a plate located on the side of the tank.
- A qualified electrician may remove the access cover by undoing the two screws on the cover and sliding the cover downward to disengage it.



**Caution: The water heater must be filled with water before turning on the electricity supply.**

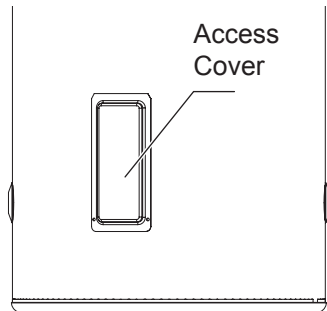



# Installation Instructions

## Commissioning The System

### Step 5

- Fill and pressurise the unit with water **BEFORE** switching on.



**Critical: Switching on the unit without water will damage it.**

- Turn on the power supply. The Hotlogic control system will then check the unit's operating parameters. If conditions are suitable and there is enough energy available in the surrounding air, the fan and compressor will turn on.
- There will be a delay of approximately **30 seconds** from the time the main power is switched on before the compressor and fan begin operating.
- The unit is self regulating so there are no internal adjustments to be made during commissioning.
- Bleed air from system through a hot water tap **not** via the PTR Valve.
- Ensure the Hotlogic® unit is displaying the green power LED once unit has been switched on.
- If the Hotlogic® unit is not displaying the green power LED, refer to the table of Hotlogic Operational Codes on page 13.
- Contact DUX Service 1300 165 115 if problems arise.

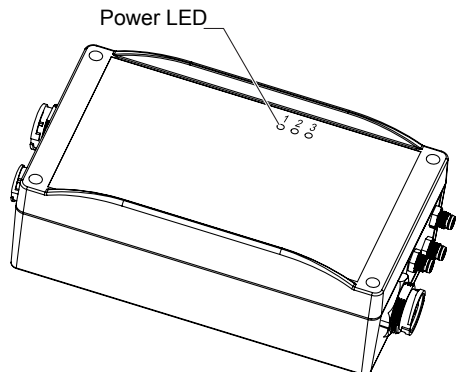



# Installation Instructions

## Conditioning Cycle

### Step 6

---

- When the unit is operated for the first time, it runs through a conditioning cycle.
- Once this has occurred, it is important to conduct a draw off of hot water, and allow the unit to re-heat prior to testing water temperature.
- Do the following:
  - After filling the tank with water, allow time for the initial heat up cycle.
  - Once its first heat up cycle is complete, empty approximately 60 litres of hot water from the tank through the PTR valve outlet.
  - Then allow the water in the tank to re-heat.
  - Once the re-heat cycle is complete, measure the water temperature at the PTR outlet again.
  - The temperature will be approximately 60° C.
- If for any reason the unit does not start, the water is cold and the Hotlogic unit is not displaying any LED lights, an electrician should test that power is available to the heat pump.
- Note: There are no installer serviceable parts within the heat pump module.



# Installation Declaration

Location of Installation: .....  
.....  
.....

Tank Serial Number: .....

Tank Model Number: .....

Date Installed: .....

Dux Hot Water terms and conditions of warranty will apply only if the below is signed by the installer. This notifies Dux Hot Water that all the requirements of proper installation have been carried out by the installer in accordance with the commissioning checklist and all other requirements noted in this manual supplied with the heat pump water heater.

Upon completion of installation, this document should be given to the home owner in its entirety. When required by Dux Hot Water, the home owner will provide this document as evidence that the installation of the heat pump water heater was carried out in accordance with installation requirements.

### Declaration

I have installed the heat pump water heater in accordance with the above instructions. If the instructions have not been followed then I understand that the terms and conditions of warranty will be void.

Name: .....

Signed: .....

Company: .....

Date: .....



# Owner's Manual

## Hotlogic Operational Codes

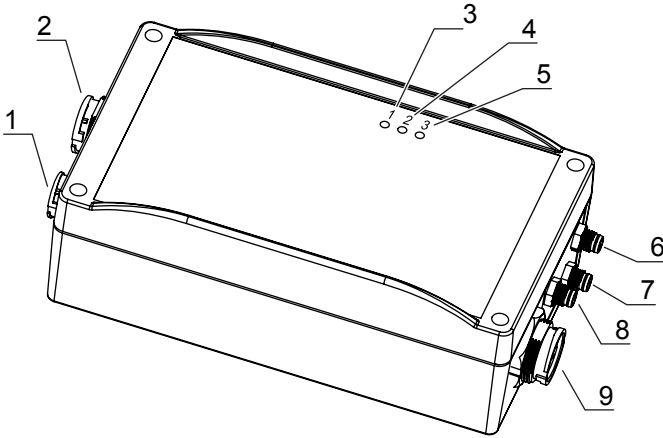

Hotlogic Components	
1	To power
2	To compressor
3	Power LED
4	Sensor LED
5	Output LED
6	To ambient sensor
7	To pressure switch
8	To tank sensor
9	To fan

LED 1 (Power)	LED 2 (Sensor)	LED 3 (Output)	Explanation
Alternating		Off	Power on initialisation (LEDs blink Red-Green alternately)
Green	Green	Green	Fan on (Compressor on/off)
Green	Flashing Red	Off	Sensor error (1 blink = ambient sensor, 2 blinks = tank sensor)
Green	Green	Red	Over Pressure Switch tripped



# Owner's Manual



Refrigeration View



Cut-through View



Main Component View





# Owner's Manual

## Safety

This appliance is not intended for use by persons (including children) with reduced physical, sensory or mental capabilities, or lack of experience and knowledge, unless they have been given supervision or instruction concerning use of the appliance by a person responsible for their safety.

Children and animals should be supervised to ensure that they do not interfere with the appliance.

## How Does The Heat Pump Module Work?

A heat pump uses complex thermodynamic principles to extract energy from ambient air and transfer this energy to water that is in contact with the unit's immersed heat exchanger. The heat pump's operational principles are similar to those used in a normal domestic refrigerator, except in reverse. In a refrigerator, heat energy is drawn from inside the refrigerator (making things cold), concentrated by the compressor then dissipated to the atmosphere via the condenser coil located on the back of the refrigerator cabinet.

In a heat pump system, outside air is drawn into the unit and across an evaporator coil by a fan. The evaporator coil captures the energy in the air and transfers that to cold liquid refrigerant, contained inside the evaporator, causing the refrigerant to increase in temperature and evaporate into a warm gas.

The warm gas on exiting the evaporator passes into a compressor where compression causes the temperature of the gas to increase further, becoming a superheated (hot) gas.

The superheated gas is pumped from the compressor to a water immersed condenser coil, where it gives up its heat energy to the water. When the superheated gas gives up energy, it condenses back to a liquid, and on exiting the condenser coil, it passes through an expansion control valve (TX valve).

The TX valve acts as an automatically adjusting tap that controls the amount of liquid refrigerant that is allowed to pass, once more, into the evaporator. This is necessary to constantly match the amount of liquid entering the evaporator to the available energy in the air passing through the evaporator so that the entire liquid refrigerant that enters evaporates and exits as a gas only.

## How Do I Operate The System?

The operation of your water heater is fully automatic, so you only need to connect the water and electricity supply and then turn on the electricity.

The heat pump module is electrically connected to the storage tank and will start automatically when the water temperature in the storage tank falls below 55°C and continue to run until the water temperature of the complete tank



# Owner's Manual

has been increased to 60°C or slightly above. To condition the unit properly allow the heat pump to go through one heat up cycle, before use, then wait 24 hours before using the hot water.

## Water Quality

Your water heater has been manufactured to suit all water conditions in “All Water Areas” present in Australia. Please note that harsh water supplies can have a detrimental effect on a water heater and its life expectancy. If you are unsure about your water quality, you can obtain information from your local water supply authority.

Water can also contain material known to create lime scale where lime scale can build up and block safety fittings. One measure of this water quality is known as the saturation index. If the saturation index is greater than 0.40 and therefore subject to lime scale, a cold water expansion control valve should be fitted to the unit, as shown in the diagram on page 6.

## How Long Will The Heat Pump Run Each Day?

The length of time that the unit will run each day will vary dependent upon the amount of hot water being used by the household and the average outdoor ambient temperature and humidity.

Generally the unit will run longer in winter and at night when the outside air temperature contains less energy.

## What Is Subzero (De-icing Function)?

Depending on the level of humidity, ice may begin to form at around 5°C on the evaporator coil, which has the potential to affect the system's performance.

The system's Hotlogic controller determines if conditions conducive to icing exist, and triggers the de-icing cycle as a result.

The de-icing cycle interrupts the flow of heated refrigerant, shuts down the compressor, and runs the fan in reverse, drawing air through the evaporator coil and past the louvers. It is this airflow which de-ices the evaporator coil. Once de-icing has occurred, the system allows the heated refrigerant to flow, and heating recommences.

## Does The Heat Pump Need Sunlight To Operate?

Heat pump water heaters extract their energy from the surrounding air and not from sunlight. For this reason they can efficiently produce hot water any time day or night and even on cloudy or overcast days. It is not uncommon for your system to operate during the night.



**Caution: All water heaters have the ability to produce hot water in a surprisingly short time. To reduce the risk of scald injury, it is mandatory under the requirements of Australian Standards AS3500 that an**



# Owner's Manual

**Australian Standards approved temperature control valve be fitted to the hot water supply pipe work. This valve should be checked at regular intervals to ensure its operation and settings remain correct.**

## Why Is There Condensation Coming From The Unit?

Condensation production is normal for all devices that use refrigeration principles. Air conditioners are a good example of systems that produce water condensation.

Condensation occurs when relatively warm moist air passes through the cold evaporator. Moisture contained in the air condenses (deposits) onto the evaporator fins, then runs down into the drainage system located under the evaporator. It is this water that you see flowing from the condensate drain of the system.

The amount of condensation will vary with the humidity of the location, so the amount of condensate that flows from the module will also vary.

When condensate is created, it runs into the "Condensate Tray" which sits on top of the storage tank. This then runs out through the "Condensate Drain" which is a feature of the tray.

A plastic drain pipe is attached to this drain allowing easy access for the plumber to attach the condensate drain

line away from the heater. The louvre incorporates a condensate drain cover, to offer protection to the drain.

## What Should I Do During Holidays?

If you are going to be away for a week or more, it is advisable to turn off the electricity supply to the system. While there is no damage likely if the electricity is left on, you will consume energy through storage tank heat losses which can be avoided.

**Warning:** If the hot water system is not used for two weeks or more, a quantity of hydrogen gas, which is highly flammable, may accumulate in the water heater. To dissipate this gas safely, it is recommended that a hot tap be turned on for several minutes at a sink, basin or bath, but not a dishwasher, clothes washer, or other appliance. During this procedure, there must be no smoking, open flame or any other electrical appliance operating nearby. If hydrogen is discharged through the tap, it will probably make an unusual noise similar to air escaping.



## Troubleshooting

### What Should I Check Before Making A Service Call?

If, after checking the troubleshooting points in the following section, the problem has not been identified, please contact the distributor from whom you purchased the system.

**Note:** It is important to know that there are no user serviceable components in the system, so it is recommended that no covers be removed and no adjustments made to the system settings by anyone other than an authorised representative.

### Water Discharge From Pressure & Temperature Relief Valve (PTR)

It is not unusual for a small quantity of water to discharge during the heating of water in your storage tank. The amount of discharge will depend on hot water usage and size of the storage tank. As a guide, it will discharge 3% of the storage capacity of water in the heating period.

### Continuous Trickle From PTR

This is most likely due to a build up of foreign matter. In this case, try gently raising the easing lever on the PTR Valve for a few seconds, then release gently. This may dislodge a small particle of foreign matter and rectify the fault.

### Steady Flow From PTR

This may be caused by excessive water supply pressure, a faulty PTR Valve, or a

faulty thermostat. Turn off the electricity supply, turn off the water, and contact your Dux agent.

### No Hot Water

- Is the Pressure & Temperature Relief Valve discharging too much water?
- Do you have the correct size water heater for your requirements? Sizing details are available from your Dux supplier.
- Is one outlet (such as the shower) using more hot water than you think?
- Carefully review the family's hot water usage and if necessary check the shower flow rates with a bucket, measuring the amount of water used over that period of time. If it is not possible to adjust water usage patterns, an inexpensive flow control valve can easily be fitted to the shower outlet.
- Consider that during night time heating, the time taken to heat the tank can take longer (less energy in the air) so you may find that the tank has not fully recovered from a period of heavy usage the previous evening.
- Consider that often the hot water usage of showers, washing machines and dishwashers can be under estimated. Review these appliances to determine if your daily usage is greater than the storage volume of your water heater. For example, if



## Troubleshooting

you have a 250 litre storage tank and you are using 390 litres of water, it is possible that there will be certain times of the day where there is insufficient hot water. It is also advisable to inspect tap washers etc. for leakage and replace if necessary.

### High Electricity Bills

- Is the Pressure & Temperature Relief Valve discharging too much water?
- Is one outlet (e.g. the shower) using more hot water than you think?
- Is there a leaking hot water pipe or dripping hot water tap? A small leak can waste a large quantity of hot water.
- Replace faulty tap washers and have your plumber rectify any leaking pipe work.

### The Unit Does Not Run

Check that the power supply is turned on and that the house circuit breakers or fuses are on and operational.



## System Maintenance

The heat pump water heater is designed to eliminate system maintenance other than that detailed in this manual.

Personally inspecting or servicing any part of the system is not recommended.

Should you decide to personally inspect the system, it is essential that you observe all normal safety practices.

### **Most importantly, the electricity supply must be turned OFF.**

Every 5 years, you should contact the local service agent to replace all safety valves and anodes to ensure continued system life and operational safety.

### **Six Monthly Service – By Owner**

Operate the Pressure & Temperature Relief Valve for approximately 10 seconds by operating the easing lever on the valve to ensure water is relieved to waste through the relief drain pipe. Check to ensure the valve closes correctly.

### **Five Year Service – By Authorised Personnel Only**

The five yearly services should be carried out by a licensed tradesperson where it is recommended that this service be carried out by your local Dux agent.

The service should include the following:

- Replace the Pressure & Temperature Relief Valve.
- Replace the anodes (in locations

where the potable water has a TDS greater than 600 ppm, this service is recommended every 3 years). All models are equipped with 2 sacrificial anodes, accessible through the top cover.

- Flush the water heater by doing the following:
  - (i) Turn off the power.
  - (ii) Turn off the cold water supply to the water heater at the isolating valve.
  - (iii) Gently operate the easing lever on the Pressure & Temperature Relief Valve to release the pressure in the water heater.
  - (iv) Disconnect the cold water inlet union to the heater and attach a drain hose.
  - (v) Gently operate the Pressure & Temperature Relief Valve to let air into the heater and allow water to escape through the hose.
  - (vi) To flush the heater, carry out steps (i) to (iv) above. Disconnect the hot water inlet union and attach a water supply hose to the heater. Turn on the water supply.
  - (vii) Flush the heater until clear water appears, then reconnect all fittings, fill the heater and restore the electricity supply.

### **Draining the Water Heater**

To drain the water heater, follow steps i to v above until no more water escapes from the appliance.



## Safety Information

For safe performance this water heater is fitted with:

- a Hotlogic controller
- a refrigerant over-pressure cut-out
- a compressor thermal cut-out
- a combination Pressure & Temperature Relief (PTR) Valve.



**Important: These devices must not be tampered with or removed. The water heater must not be operated unless these devices are fitted and in working order.**

### Electrical Cover

The electrical cover should be removed only by an electrician. The electrical power supply switch must be turned off and the fuse removed at the main electrical supply switchboard before the water heater's electrical cover is removed.

### PTR Valve

The PTR Valve should be checked for adequate performance or replaced at intervals not exceeding 5 years, or less in areas where local regulations apply.

The lever on the relief valve should be pulled to operate the valve at least once every six months.



**Danger: Failure to operate the relief valve easing gear at least once every six months may result in the water heater exploding. Continuous leakage of water from the valve may indicate a problem with the water heater.**

**Note:** The PTR valve and the drain outlet pipe must not be sealed or blocked. It is normal for the valve to overflow during heating cycles.



## Warranty

### Dux Hot Water Unit

**Manufactured by Dux Manufacturing Limited (“Dux”)**

### Terms of Warranty and Replacement Guarantee

All Airoheat water heaters manufactured and sold after 1 January 2011 are backed by a comprehensive one (1) year full parts and labour warranty (conditions apply – see below).

Furthermore, the Airoheat tank includes a guarantee to replace your hot water unit if the inner cylinder fails within five (5) years (conditions apply – see below).

The terms of the Warranty and replacement guarantee are set out below.

#### **1 Year Comprehensive Warranty**

Your hot water system and its components (“Unit”) are covered by 1 year (parts and labour) warranty against defective factory materials or workmanship.

This warranty period commences from the date of installation of the Unit providing you have proof of this installation date. Where the date of completion of installation is not known or cannot be proven, then this warranty will commence one (1) month after the date of manufacture (refer to the data label on the unit).

#### **2 Year Refrigerant Components Replacement Guarantee**

If a refrigerant component fails, within a further one (1) year after the end of the initial warranty period, Dux will provide a full refrigerant parts and labour replacement guarantee for these components, at the nearest approved Dux agent or Dux office to the owner's home. Under this replacement guarantee, the transport, installation and labour costs of delivering the replacement components are included.

#### **5 Year Replacement Guarantee**

If an inner cylinder fails on a Dux hot water unit within a further four (4) years after the end of the initial one (1) year warranty period, Dux will provide a free replacement hot water unit at the nearest approved Dux agent or Dux office to the owner's home. Under this replacement guarantee, the transport, installation and labour costs of delivering the replacement hot water unit and removing and replacing the existing hot water unit will be the responsibility of the owner of the existing hot water unit.

#### **Conditions of Warranty and Replacement Guarantee**

The benefits provided to you by the warranty and replacement guarantee (collectively “Warranty”) are in addition to the guarantees and other rights and remedies available to you under the Australian Consumer Law (“ACL”).





## Warranty

If the Unit fails to conform to this Warranty during the applicable period, Dux will replace any failed component or where necessary, in the absolute discretion of Dux, replace the Unit free of charge including reasonable labour costs incurred in normal business working hours.

This Warranty only applies to defects which have arisen solely from faulty materials or workmanship in the Unit and does not apply to other defects which may have arisen as a result of, without limitation, the following: accidental damage, abuse, misuse, maltreatment, abnormal stress or strain, harsh or adverse water conditions including excessive water pressure or temperature, neglect of any kind or otherwise as a result of any use of the Unit contrary to the product manual or other instructions provided by Dux. Alterations or repair of the Unit other than by an accredited and licensed service agent or technician are not covered. Attachment of accessories or use of non genuine replacement parts other than those manufactured or approved by Dux are not covered by this Warranty.

This Warranty applies only to the Unit and does not cover any ancillary plumbing or electrical parts supplied by the installer such as pressure limiting valve, tempering valve, line strainer, stop cocks, non-return valve, electrical switches, pumps or fuses, or faulty installation.

The Unit must be installed by a licensed plumber in accordance with information set out in the manual supplied with the Unit and/or any relevant statutory requirements.

In addition to this Warranty, certain legislation (including the ACL) may give you rights which cannot be excluded, restricted or modified. This Warranty must be read subject to such legislation and nothing in this Warranty has the effect of excluding, restricting or modifying those rights.

If Dux fails to meet a guarantee under the ACL, your remedy for such failure may be limited to any one or more of the following:

- replacement of the Unit;
- repair of the Unit;
- refunding the cost of the Unit;
- payment of reasonable costs of having the Unit repaired;
- payment in respect of the reduced value of the Unit.

Any defective part of the Unit must be returned to the point of sale before replacement can be considered under the terms of this Warranty. If the costs of returning any defective parts are unreasonable, please contact Dux on 1300 365 115 (Australia) or 0800 729 389 (New Zealand) so that we can arrange a collection if appropriate.



## Warranty

Warranty claims can be made at the point of sale or by posting or faxing a warranty claim to Dux (contact details listed below) within one (1) month of the appearance of a defect. Warranty claims under this extended warranty must include the following details:

- Date of Purchase;
- Location of Purchase;
- Proof of Purchase;
- Date of Installation;
- Contact Details
- Product Serial Number

### Contact Details

Dux' contact details are as follows:

#### Business Address:

Dux Manufacturing Limited  
Lackey Road  
Moss Vale, NSW, 2577  
Australia

#### Telephone:

1300 365 115 (Australia)  
0800 729 389 (New Zealand)

#### Facsimile:

(61 2) 4868 0257

#### Email:

[duxaftersales@gwagroup.com.au](mailto:duxaftersales@gwagroup.com.au)

**Note:** If the Unit is located in a position that does not comply with the installation instructions or relevant

statutory requirements, then this Warranty does not cover major dismantling or removal of cupboards, doors, walls or special equipment and/or excessive labour, at the determination of Dux, to make the Unit accessible for repair or replacement.

As required by legislation, including under the ACL, any claims for damage to furniture, carpets, walls, foundations or any other consequential loss either directly or indirectly due to defects of any kind in a Unit will only be met by Dux where the damage could be considered reasonably foreseeable.

Our goods come with guarantees that cannot be excluded under the Australian Consumer Law. You are entitled to a replacement or refund for a major failure and for compensation for any other reasonably foreseeable loss or damage. You are also entitled to have the goods repaired or replaced if the goods fail to be of acceptable quality and the failure does not amount to a major failure.



# Other Information

Product Warranty is applicable only in Australia and New Zealand.

See page 22 for terms of warranty.

*Privacy Act Amendment (2000):* If and whenever warranty service is required, your personal details will be given to an Authorised Dux Service Agent only for the express purpose of carrying out the arranged warranty service work agreed by you the client and Dux Manufacturing Limited.

### Your Details

For future convenience, fill in the following details and retain with your original invoice for your own records.

Surname:.....Given Name(s):.....

Address:.....

Town/Suburb:.....

State/Territory:..... Postcode:.....

Date of Purchase:..... Purchased From:.....

Model:..... Serial Number (located on back cover):.....

Date of Manufacture:.....

(Details on Data Label on water heater)

### Installer's Details:

Date of Installation:..... Installer's Name:.....

Address:.....

Installer's Signature:.....

### Service Details:

Date of Service:..... Serviced By:.....

Work Carried Out:.....

.....

.....

Signature of Service Agent:.....



# airoheat®

## Heat Pump Water Heater

For advice, repairs and service, call:

1300 365 115 (Australia)

0800 729 389 (New Zealand)



### Please Register Your Water Heater



Please take a moment to fill out your details for warranty registration at:

[www.dux.com.au/warranty](http://www.dux.com.au/warranty)

or use your smartphone to scan this code:



This will ensure all your current details are registered with us for prompt warranty service if required.

### Preventative Maintenance



Maintaining your hot water system will help extend its lifespan and reduce running costs.

Please register for preventative maintenance at:

[www.dux.com.au/maintenance](http://www.dux.com.au/maintenance)

Serial Number

