

INSTALLATION and maintenance manual

Table of Contents

Model Nomenclature	1
Introduction	2
Initial Inspection	2
General Description	2
Moving and Storage	2
Safety Considerations	2
Location	2
Installation	2
Condensate Drain	3
Duct System	3
Electrical	4
Piping	4
Well Water Systems	5
Cooling Tower / Boiler Application	5
Earth Coupled Systems	5
System Checkout	7
Unit Start-Up	7
Maintenance	8
Operating Pressures & Temperatures	9
Unit Check-Out	16
Trouble Shooting	17

MODEL NOMENCLATURE

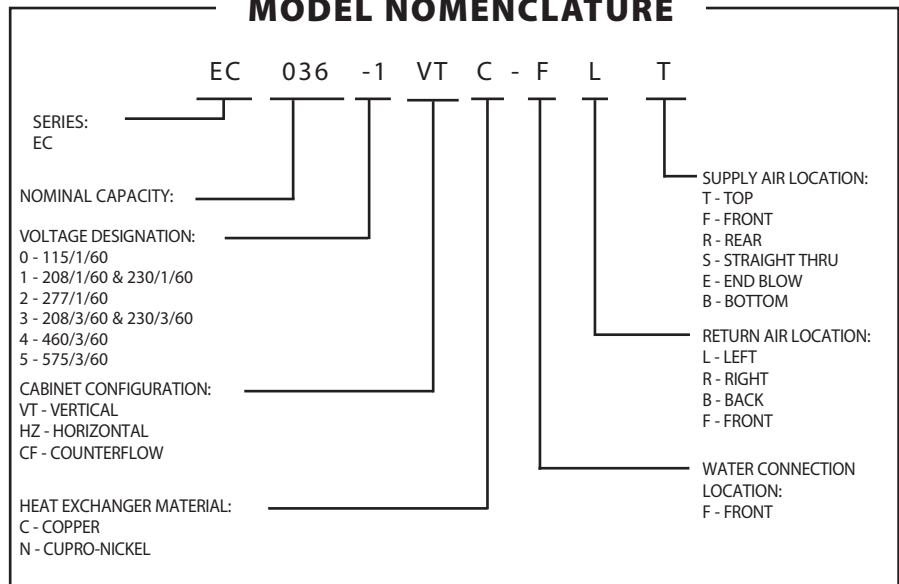

INTRODUCTION:

The EC Series uses scroll and reciprocating compressors and refrigerant R-410A to achieve high efficiency levels, quiet operation and reliable performance.

The new refrigerant provides performance similar to that of R-22 with one major advantage. Refrigerant R-410A is an HFC so it does not contain any ozone depleting HCFC's or CFC's.

INITIAL INSPECTION:

Be certain to inspect all cartons or crates on each unit as received at the job site before signing the freight bill. Verify that all items have been received and that there are no visible damages; note any shortages or damages on all copies of the freight bill. In the event of damage or shortage, remember that the purchaser is responsible for filing the necessary claims with the carrier. Concealed damages not discovered until after removing the units from the packaging must be reported to the carrier within 24 hours of receipt.

GENERAL DESCRIPTION:

The EC Water-to-Air Heat Pumps provide the best combination of performance and efficiency available. Safety devices are built into each unit to provide the maximum system protection possible when properly installed and maintained.

The EC Water-to-Air Heat Pumps are Underwriters Laboratories (UL), (CE) and (CUL) listed for safety. The EC Water-to-Air Heat Pumps are designed to operate with entering liquid temperature between 50° F and 100° F. With the extended range option, the heat pump can operate with entering liquid temperatures between 25° F and 110° F.

NOTE: 50° F Min. EWT for well water applications with sufficient water flow to prevent freezing. Antifreeze solution is required for all closed loop applications.

Cooling Tower/ Boiler and Earth Coupled (GeoThermal) applications should have sufficient antifreeze solution to protect against extreme conditions and equipment failure. Frozen water coils are not covered under warranty.

WARNING: This product should not be used for temporarily heating/cooling during construction. Doing so may effect the units warranty.

MOVING AND STORAGE:

If the equipment is not needed for immediate installation upon its arrival at the job site, it should be left in its shipping carton and stored in a clean, dry area. Units must only be stored or moved in the normal upright position as indicated by the "UP" arrows on each carton at all times. If unit stacking is required, stack units as follows: Vertical units less than 6 tons, no more than two high. Horizontal units less than 6 tons, no more than three high. "Do not stack units larger than 6 tons."

SAFETY CONSIDERATIONS:

CAUTION: R-410A systems operate at higher pressures than standard R-22 systems. Do not use R-22 service equipment or components on R-410A equipment.

Installation and servicing of this equipment can be hazardous due to system pressure and electrical components. Only trained and qualified personnel should install, repair, or service the equipment. Untrained personnel can perform basic functions of maintenance such as cleaning coils and replacing filters.

WARNING: Before performing service or maintenance operations on the system, turn off main power to the unit. Electrical shock could cause personal injury or death.

When working on equipment, always observe precautions described in the literature, tags, and labels attached to the unit. Follow all safety codes. Wear safety glasses and work gloves. Use a quenching cloth for brazing, and place a fire extinguisher close to the work area.

LOCATION:

Locate the unit in an indoor area that allows easy removal of the filter and access panels, and has enough room for service personnel to perform maintenance or repair. Provide sufficient room to make water, electrical, and duct connection(s). If the unit is located in a confined space such as a closet, provisions must be made for return air to freely enter the space. On horizontal units, allow adequate room below the unit for a condensate drain trap and do not locate the unit above supply piping. These units are not approved for outdoor installation; therefore, they must be installed inside the structure being conditioned. Do not locate in areas that are subject to freezing.

INSTALLATION:

WARNING: Remove all shipping blocks under blower housing. Loosen compressor mounting bolts.

MOUNTING VERTICAL UNITS:

Vertical units up to five tons are available in left, right, front, or rear air return configurations. Vertical units should be mounted level on a vibration absorbing pad slightly larger than the base to minimize vibration transmission to the building structure. It is not necessary to anchor the unit to the floor. (See Figure #1). Vertical units larger than five tons

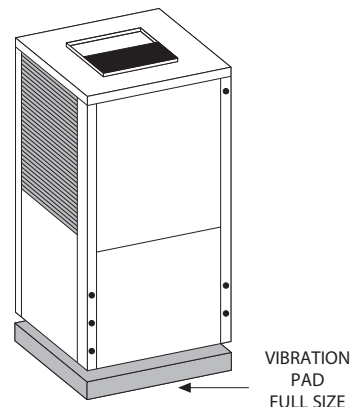

(Figure #1)

should be vibration isolated according to the design engineers specifications.

MOUNTING HORIZONTAL UNITS:

While horizontal units may be installed on any level surface strong enough to hold their weight, they are typically suspended above a ceiling by threaded rods. The rods are usually attached to the unit corners by hanger bracket kits (P/N 930-004, or 006). (See Figure #2). The rods must be securely anchored to the ceiling. Refer to the hanging bracket assembly and installation instructions for details. Units larger than six tons include an integral angle iron frame with mounting holes present. (See unit horizontal detail drawing). Horizontal units installed above the ceiling must conform to all local codes. An auxiliary drain pan if required by code, should be at least four inches larger than the bottom of the heat pump. Plumbing connected to the heat pump must not come in direct contact with joists, trusses, walls, etc..

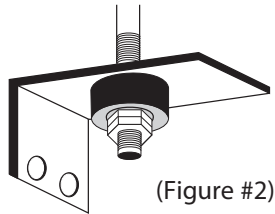

(Figure #2)

Some applications require an attic floor installation of the horizontal unit. In this case the unit should be set in a full size secondary drain pan on top of a vibration absorbing mesh. The secondary drain pan prevents possible condensate overflow or water leakage damage to the ceiling. The secondary drain pan is usually placed on a plywood base isolated from the ceiling joists by additional layers of vibration absorbing mesh. In both cases, a 3/4" drain connected to this secondary pan should be run to an eave at a location that will be noticeable. If the unit is located in a crawl space, the bottom of the unit must be at least 4" above grade to prevent flooding of the electrical parts due to heavy rains.

CONDENSATE DRAIN:

WARNING: If equipped with float style condensate overflow switch, final adjustment must be made in the field.

A drain line must be connected to the heat pump and pitched away from the unit a minimum of 1/8" per foot to allow the condensate to flow away from the unit.

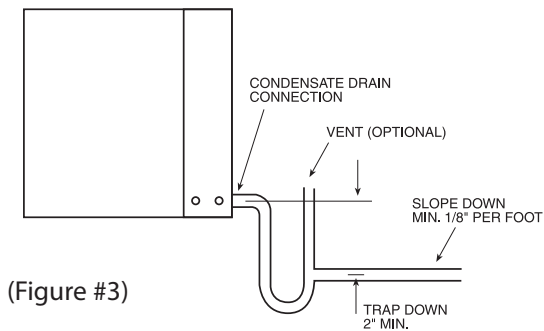

(Figure #3)

This connection must be in conformance with local plumbing codes. A trap must be installed in the condensate line to insure free condensate flow. (Units are not internally trapped). A vertical air vent is sometimes required to avoid

air pockets. (See Figure #3). The length of the trap depends on the amount of positive or negative pressure on the drain pan.

A second trap must not be included. The horizontal unit should be pitched approximately 1/4" towards the drain in both directions, to facilitate condensate removal. (See Figure #4)

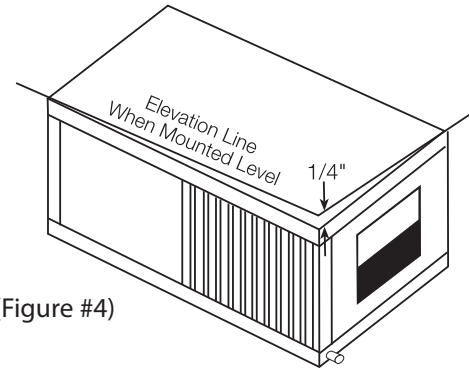

(Figure #4)

DUCT SYSTEM:

All EC models are provided with a return air duct flange, while a supply air outlet collar is provided on all models except the 6 thru 12 ton horizontal models to facilitate duct connections. Refer to the individual data specification sheet for physical dimensions of the collar and flange.

A flexible connector is recommended for supply and return air connections on metal duct systems. All metal ducting should be insulated with a minimum of one inch duct insulation to avoid heat loss or gain and prevent condensate forming during the cooling operation. Application of the unit to uninsulated duct work is not recommended as the unit's performance will be adversely affected. Do not connect discharge ducts directly to the blower outlet. The factory provided air filter must be removed when using a filter back return air grill. The factory filter should be left in place on a free return system.

If the unit will be installed in a new installation with new duct work, the installation should be designed using current ASHRAE procedures for duct sizing. If the unit will be connected to an existing duct system, a check should be made to assure that the duct system has the capacity to handle the air required for the unit application. If the duct system is too small, larger duct work must be installed. Be certain to check for existing leaks and repair.

The duct system and all diffusers should be sized to handle the designed air flow quietly. To maximize sound attenuation of the unit blower, the supply and return air plenums should be insulated. There should be no direct straight air path thru the return air grille into the heat pump. The return air inlet to the heat pump must have at least one 90 degree turn away from the space return air grille. If air noise or excessive air flow are a problem, the blower speed can be changed to a lower speed to reduce air flow.

ELECTRICAL:

All field wiring must comply with local and national fire, safety and electrical codes. Power to the unit must be within the operating voltage range indicated on the unit's nameplate. On three phase units, phases must be balanced within 2%.

Properly sized fuses or HACR circuit breakers must be installed for branch circuit protection. See equipment rating plate for maximum size. The unit is supplied with an opening for attaching conduit. Be certain to connect the ground lead to the ground lug in the control box. Connect the power leads as indicated on the unit wiring diagram.

THERMOSTAT CONNECTIONS:

Thermostat wiring is connected to the 5-position (6-position on dual compressor models) low voltage terminal block located in the upper portion of the electrical box. The thermostat connections and their functions are as follows:

C	Transformer 24 VAC Common
O	Reversing Valve (energized in cooling)
Y	Compressor contactor
Y1	1ST stage compressor contractor (dual-compressor unit)
Y2	2ND stage compressor contractor (dual-compressor unit)
R	Transformer 24 VAC Hot
G	Fan

SAFETY DEVICES AND THE UPM CONTROLLER

Each EC unit is factory provided with a Unit Protection Module (UPM) that controls compressor operation and monitors the safety controls that protect the unit.

Safety controls include the following:

- High pressure switches located in the refrigerant discharge lines. One per refrigeration circuit.
- Low pressure switches located in the unit refrigerant suction lines. One per refrigeration circuit.
- Optional freeze protection sensor located on the leaving side of the water coil prevents unit operation below 35°F. A freeze stat pin located on the board may be put in the YES or NO position depending whether the freeze stat is ordered.

NOTE: The factory default is in the YES position. If the freeze stat option is not ordered the pin must be relocated to the NO position.

- Optional Condensate overflow protection sensor located in the drain pan(s) of the unit and wired to the UPM board.

The UPM includes the following features:

- **ANTI-SHORT CYCLE TIMER** – 5 minute delay on break timer to prevent compressor short cycling.
- **RANDOM START** – Each controller has a unique random start delay ranging from 270 to 300 seconds.
- **LOW PRESSURE BYPASS TIMER** - The low pressure switch is bypassed for 120 seconds after compressor

start-up to prevent nuisance low pressure lockouts during cold start-up in the heating mode.

- **BROWNOUT/SURGE/POWER INTERRUPTION PROTECTION** – a 20 millisecond window is monitored for the above condition. Should any of these conditions be detected, the 5-minute delay on break timer and the random start timer delay are initiated.
- **MALFUNCTION OUTPUT** – The controller has a set of wet contacts for remote fault indication.
- **TEST SERVICE PIN** – A jumper pin is provided to reduce all time delay settings to 5 seconds during troubleshooting or verification of unit operation. Note that operation of the unit in test mode can lead to accelerated wear and premature failure of the unit.
- **L.E.D. FAULT INDICATION** – Two L.E.D. indicators are provided as follows:

- **GREEN:** Power L.E.D. indicates 18 – 30 VAC present at the board.
- **RED:** Fault indicator with blink codes as follows:

SINGLE COMPRESSOR UNITS (UPM-I)	
One blink	High pressure lockout
Two blinks	Low pressure lockout
Three blinks	Freeze sensor lockout
Four blinks	Condensate overflow
Five blinks	Brownout Conditions
DUAL COMPRESSOR UNITS (UPM-II)	
One blink	1st Stage high pressure lockout
Two blinks	1st Stage low pressure lockout
Three blinks	2nd Stage high pressure lockout
Four blinks	2nd Stage low pressure lockout
Five blinks	Freeze Protection lockout
Six blinks	Condensate overflow lockout

- **INTELLIGENT RESET** - If a fault condition is initiated the 5 minute delay on break time period and the random start timer are initiated and the unit will restart after these delays expire. During this period the fault LED will indicate the cause of the fault. If the fault condition still exists or reoccurs before one hour, the unit will go into a hard lockout and requires a manual lockout reset. A condensate overflow fault will cause the unit to go into a hard lockout immediately.
- **LOCKOUT RESET** - A hard lockout can be reset by turning the unit thermostat off and then back on or by shutting off unit power at the circuit breaker.

NOTE: The blower motor will remain active during a lockout condition.

PIPING:

Supply and return piping must be as large as the unit connections on the heat pump (larger on long runs). Never use flexible hoses of a smaller inside diameter than that of

the water connections on the unit. EC Units are supplied with either a copper or optional cupro-nickel condenser. Copper is adequate for ground water that is not high in mineral content. Should your well driller express concern regarding the quality of the well water available or should any known hazards exist in your area, we recommend proper testing to assure the well water quality is suitable for use with water source equipment. In conditions anticipating moderate scale formation or in brackish water a cupro-nickel heat exchanger is recommended.

Both the supply and discharge water lines will sweat if subjected to low water temperature. These lines should be insulated to prevent damage from condensation.

All manual flow valves used in the system must be ball valves. Globe and gate valves must not be used due to high pressure drop and poor throttling characteristics. Never exceed the recommended water flow rates. Serious damage or erosion of the water to refrigerant heat exchanger could occur.

Always check carefully for water leaks and repair appropriately. Units are equipped with female pipe thread fittings. Consult the specification sheets for sizes. Teflon tape sealer should be used when connecting water piping connections to the units to insure against leaks and possible heat exchanger fouling. Do not overtighten the connections. Flexible hoses should be used between the unit and the rigid system to avoid possible vibration. Ball valves should be installed in the supply and return lines for unit isolation and unit water flow balancing.

Pressure/temperature ports are recommended in both the supply and return lines for system flow balancing. The water flow can be accurately set by measuring the water-to-refrigerant heat exchangers water side pressure drop. See the unit specification sheets for the water flow and pressure drop information.

CAUTION: Water piping exposed to extreme, low ambient temperatures is subject to freezing.

WELL WATER SYSTEMS: (50° F EWT Min.)

(Figure #5)

When a water well is used exclusively for supplying water to the heat pump, the pump should operate only when the heat pump operates. A 24 volt, double pole single throw (DP/ST) contactor can be used to operate the well pump with the heat pump.

When two or more units are supplied from one well, the pump can be wired to operate independently from either unit. Two 24-volt double pole single throw relays wired in parallel are required. An upsized VA transformer may be required in either case.

The discharge water from the heat pump is not contaminated in any manner and can be disposed of in various ways depending on local codes (i.e. discharge well, dry well, storm sewer, drain field, stream, pond, etc.)

COOLING TOWER / BOILER APPLICATION:

(Figure #6)

To assure adequate cooling and heating performance, the

cooling tower and boiler water loop temperature should be maintained between 50°F to 75°F in the heating mode and 60°F to 110°F in the cooling mode. In the cooling mode, heat is rejected from the unit into the water loop. A cooling tower provides evaporative cooling to the loop fluid; thus, maintaining a constant supply temperature to the unit. When utilizing an open cooling tower, chemical water treatment is mandatory to ensure the water is free of corrosive materials.

A secondary heat exchanger (plate frame between the unit and the open cooling tower) may also be used. It is imperative that all air is eliminated from the closed loop side of the heat exchanger to prevent condenser fouling.

In the heating mode, heat is absorbed from the water loop to the unit. A boiler can be utilized to maintain the loop within the proper temperature range.

No unit should be connected to the supply or return piping until the water system has been completely cleaned and flushed to remove dirt, piping chips or other foreign material. Supply and return hoses should be connected together during this process to ensure the entire system is properly flushed. After the cleaning and flushing has taken place the unit may be connected to the water loop and should have all valves wide open.

EARTH COUPLED SYSTEMS: (Figure #7)

Operation of an EC Series unit on a closed loop application requires the extended range option.

NOTE: Closed loop and pond applications require specialized design knowledge. No attempt at these installations should be made unless the dealer has received specialized training.

Utilizing Ground Loop Pumping Package (GLP), makes the installation easy. Anti-freeze solutions must be utilized when low evaporating conditions are expected to occur. Refer to the installation manuals for more specific instructions.

IN-WARRANTY MATERIAL RETURN:

When contacting your FHP Representative for service or replacement parts, refer to the model and serial number of the unit as stamped on the data plate attached to the unit.

All warranty material returned to the factory for credit must be accompanied by a material return material tag. Enter the information as called for on the tag in order to expedite handling and insure prompt issuance of credits.

Freight charges for all items returned to the factory shall be prepaid. The return of the part does not constitute an order for a replacement. Therefore, a purchase order must be entered through your nearest representative. The order shall include the part number, model number, and serial number of the unit involved. If the part is within the warranty period, and after our inspection of the returned part proves that the failure is due to faulty material or workmanship a credit or replacement part will be issued.

All warranty parts shall be returned freight prepaid to:

FHP Manufacturing Company
601 N.W. 65TH Court • Fort Lauderdale, FL 33309

(Figure #5)

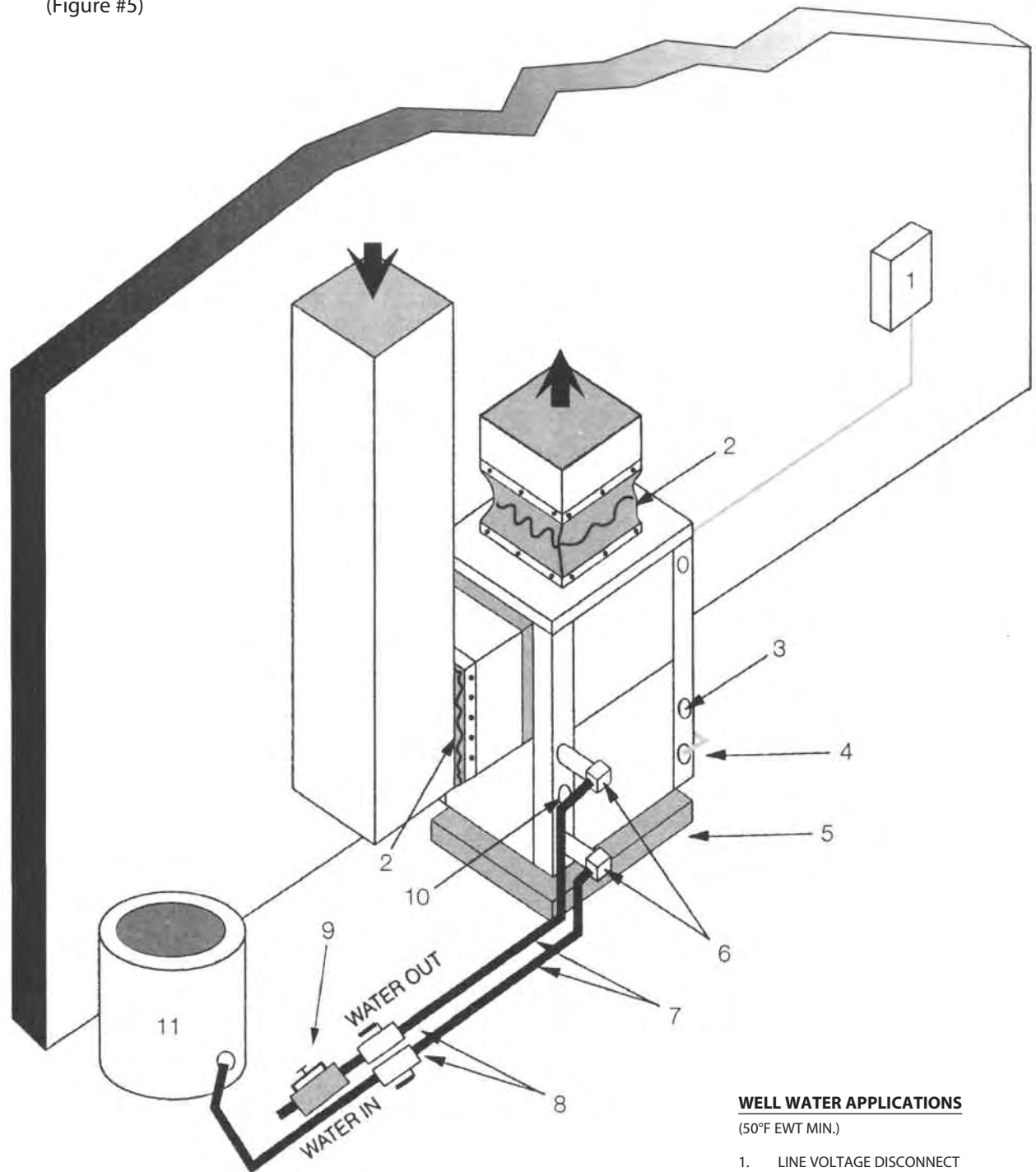

WELL WATER APPLICATIONS

(50°F EWT MIN.)

- 1. LINE VOLTAGE DISCONNECT
- 2. FLEX DUCT CONNECTION
- 3. LOW VOLTAGE CONTROL CONNECTION
- 4. LINE VOLTAGE CONNECTION
- 5. VIBRATION PAD
- 6. P/T PORTS
- 7. HOSE KITS (Optional)
- 8. BALL VALVES
- 9. SOLENOID VALVE SLOW CLOSING
- 10. CONDENSATE DRAIN CONNECTION
- 11. PRESSURE TANK (Optional)

NOTE: SEE FIGURE #3 FOR CONDENSATE DRAIN CONNECTION

SYSTEM CHECKOUT:

- After completing the installation, and before energizing the unit, the following system checks should be made:
- Verify that the supply voltage to the heat pump is in accordance with the nameplate ratings.
- Make sure that all electrical connections are tight and secure.
- Check the electrical fusing and wiring for the correct size.
- Verify that the low voltage wiring between the thermostat and the unit is correct.
- Verify that the water piping is complete and correct.
- Check that the water flow is correct, and adjust if necessary.
- Check the blower for free rotation, and that it is secured to the shaft.
- Verify that vibration isolation has been provided.
- Unit is serviceable. Be certain that all access panels are secured in place.

UNIT START-UP:

1. Set the thermostat to the highest setting.
2. Set the thermostat system switch to "COOL", and the fan switch to the "AUTO" position. The reversing valve solenoid should energize. The compressor and fan should not run.
3. Reduce the thermostat setting approximately 5 degrees below the room temperature.
4. Verify the heat pump is operating in the cooling mode.
5. Turn the thermostat system switch to the "OFF" position. The unit should stop running and the reversing valve should deenergize.
6. Leave the unit off for approximately (5) minutes to allow for system equalization.
7. Turn the thermostat to the lowest setting.
8. Set the thermostat switch to "HEAT".
9. Increase the thermostat setting approximately 5 degrees above the room temperature.
10. Verify the heat pump is operating in the heating mode.

(Figure #6)

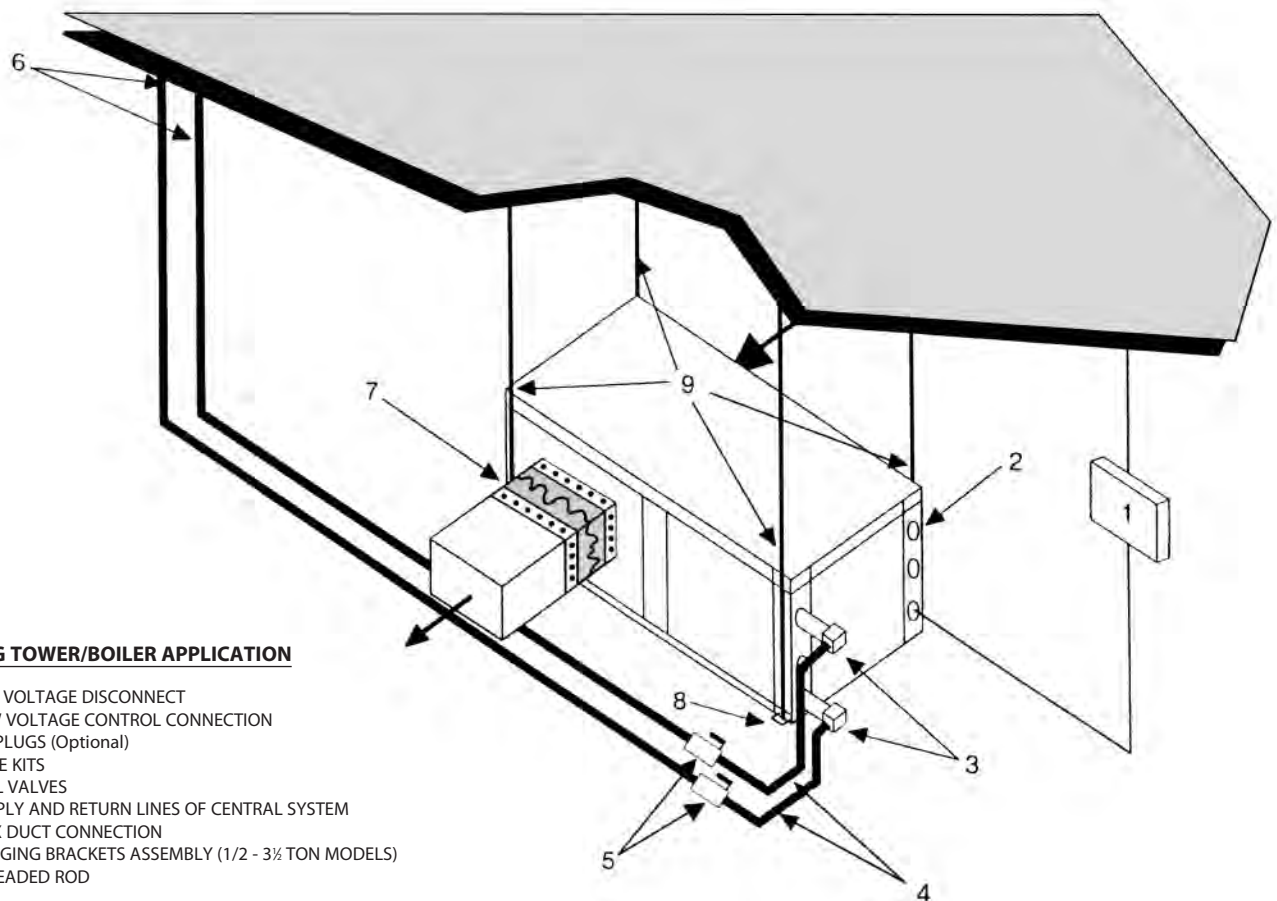

COOLING TOWER/BOILER APPLICATION

1. LINE VOLTAGE DISCONNECT
2. LOW VOLTAGE CONTROL CONNECTION
3. P/T PLUGS (Optional)
4. HOSE KITS
5. BALL VALVES
6. SUPPLY AND RETURN LINES OF CENTRAL SYSTEM
7. FLEX DUCT CONNECTION
8. HANGING BRACKETS ASSEMBLY (1/2 - 3/4 TON MODELS)
9. THREADED ROD

NOTE: SEE FIGURE #3 FOR CONDENSATE DRAIN CONNECTION

11. Set the thermostat to maintain the desired space temperature.
12. Check for vibrations, leaks, etc...
13. Instruct the owner on the unit and thermostat operation.

MAINTENANCE:

1. Filter changes or cleanings are required at regular intervals. The time period between filter changes will depend upon type of environment the equipment is used in. In a single family home, that is not under construction, changing or cleaning the filter every 60 days is sufficient. In other applications, such as motels, where daily vacuuming produces a large amount of lint, filter changes may need to be as frequent as biweekly.
2. An annual "checkup" is recommended by a licensed refrigeration mechanic. Recording the performance measurements of volts, amps, and water temperature differences (both heating and cooling) is recommended. This data should be compared to the information on the unit's data plate and the data taken at the original startup of the equipment.

3. Lubrication of the blower motor is not required, however, may be performed on some motors to extend motor life. Use SAE-20 non-detergent electric motor oil.
4. The condensate drain should be checked annually by cleaning and flushing to insure proper drainage.
5. Periodic lockouts almost always are caused by air or water flow problems. The lockout (shutdown) of the unit is a normal protective measure in the design of the equipment. If continual lockouts occur call a mechanic immediately and have them check for: water flow problems, water temperature problems, air flow problems or air temperature problems. Use of the pressure and temperature charts for the unit may be required to properly determine the cause.

(Figure #7)

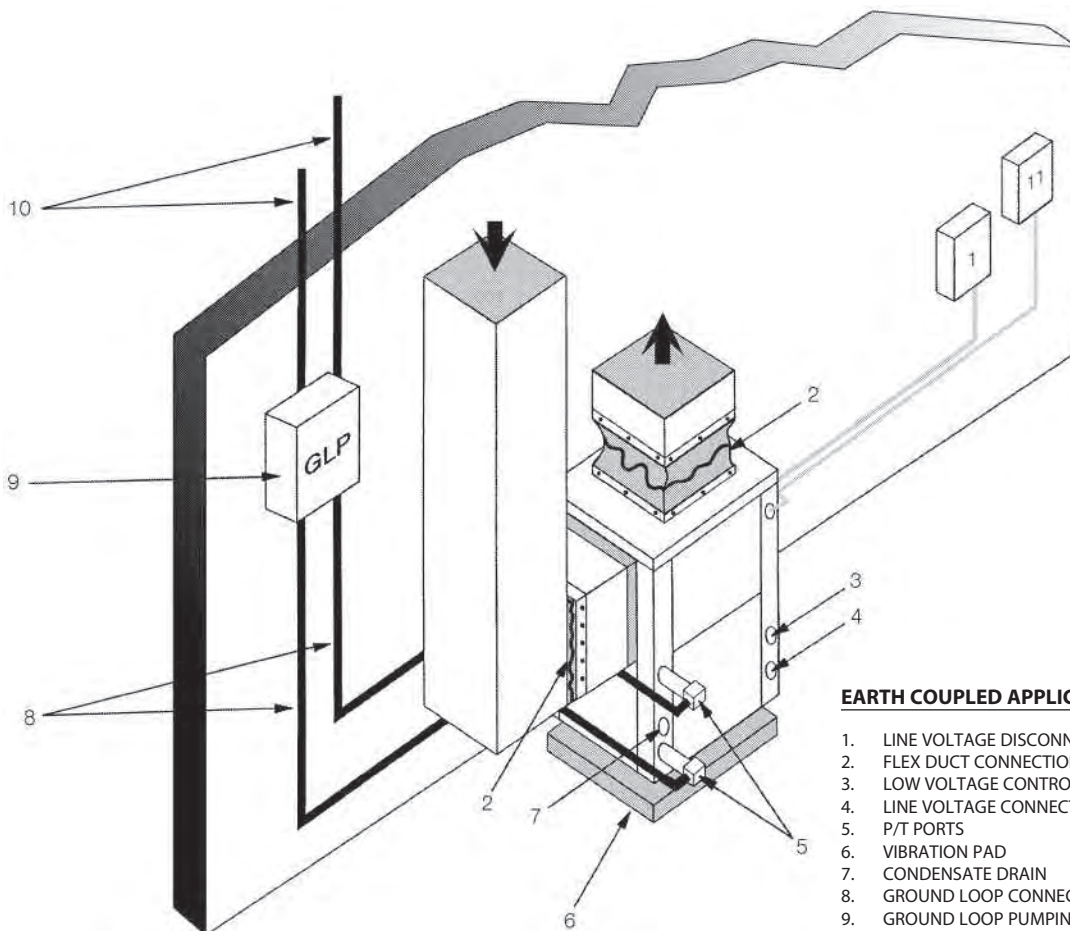

EARTH COUPLED APPLICATION

1. LINE VOLTAGE DISCONNECT (UNIT)
2. FLEX DUCT CONNECTION
3. LOW VOLTAGE CONTROL CONNECTION
4. LINE VOLTAGE CONNECTION (UNIT)
5. P/T PORTS
6. VIBRATION PAD
7. CONDENSATE DRAIN
8. GROUND LOOP CONNECTION KIT
9. GROUND LOOP PUMPING PACKAGE (GL001-1 or 002-1)
10. POLYETHYLENE WITH INSULATION
11. LINE VOLTAGE DISCONNECT (ELECTRIC HEATER)

NOTE: SEE FIGURE #3 FOR CONDENSATE DRAIN CONNECTION

Operating Temperatures & Pressures, EC007-012

			OPERATING DATA								
			COOLING				HEATING				
MODEL	ENTERING WATER TEMP, °F	WATER FLOW GPM	SUCTION PRESSURE PSIG	DISCHARGE PRESSURE PSIG	WATER TEMP RISE, °F	AIR TEMP DROP, °F	SUCTION PRESSURE PSIG	DISCHARGE PRESSURE PSIG	WATER TEMP DROP, °F	AIR TEMP RISE, °F	
EC007	30°	1.4					65-80	282-344	6-7	14-17	
		1.9					73-89	294-359	3-4	15-18	
	40°	1.4	106-129	146-178	17-21	18-22	80-98	299-365	7-9	16-20	
		1.9	102-124	133-162	10-13	19-23	89-108	311-380	4-5	17-21	
	50°	1.4	115-141	180-220	17-20	17-21	95-116	315-385	9-11	19-23	
		1.9	111-135	163-200	10-12	18-23	105-128	329-402	5-7	20-24	
	60°	1.4	124-152	213-261	16-19	17-21	109-133	332-406	11-13	21-26	
		1.9	120-146	194-237	10-12	18-22	121-148	346-423	6-8	22-27	
	70°	1.4	134-163	247-302	15-19	17-20	124-151	349-427	12-15	23-28	
		1.9	128-157	225-275	9-11	18-21	138-168	364-444	7-9	25-30	
	80°	1.4	143-175	281-343	14-18	16-20	138-169	366-447	14-17	26-31	
		1.9	137-168	255-312	9-11	17-21	154-188	381-466	8-10	27-33	
	90°	1.4	152-186	315-385	14-17	16-19	153-187	383-468	16-19	28-34	
		1.9	146-179	286-350	8-10	17-20	170-208	399-487	9-12	29-36	
	100°	1.4	161-197	349-426	13-16	15-19					
		1.9	155-190	317-387	8-10	16-20					
	EC009	30°	1.8					91-111	251-307	5-6	21-25
			2.4					95-116	256-313	3-4	22-26
40°		1.8	112-137	144-176	14-17	22-27	107-130	267-327	6-7	24-29	
		2.4	106-130	137-167	10-12	23-28	112-137	273-333	4-5	25-30	
50°		1.8	116-142	177-217	13-16	21-26	123-150	284-347	7-9	27-33	
		2.4	111-135	169-206	9-12	22-27	129-158	289-353	5-6	28-34	
60°		1.8	121-148	211-258	13-16	21-26	139-170	300-366	8-10	30-37	
		2.4	115-140	200-245	9-11	22-27	146-179	306-374	6-7	32-39	
70°		1.8	126-154	245-299	13-15	20-25	156-190	316-386	9-12	33-41	
		2.4	119-146	232-284	9-11	21-26	163-200	322-394	7-8	35-43	
80°		1.8	130-159	278-340	12-15	20-24	172-210	332-406	11-13	36-44	
		2.4	124-151	264-323	9-11	21-26	180-220	339-414	8-9	38-47	
90°		1.8	135-165	312-381	12-15	19-24	188-230	349-426	12-15	39-48	
		2.4	128-157	296-362	9-10	20-25	197-241	355-434	8-10	41-51	
100°		1.8	140-171	345-422	12-14	19-23					
		2.4	133-162	328-401	8-10	20-24					
EC012		30°	2.6					73-89	266-325	5-6	15-18
			3.0					77-94	272-333	3-4	16-19
	40°	2.6	117-143	189-231	14-17	18-22	86-105	279-341	6-7	17-21	
		3.0	112-137	178-217	8-9	19-24	90-110	286-350	4-5	18-22	
	50°	2.6	126-154	221-270	14-17	18-21	162-198	293-358	7-8	20-24	
		3.0	121-148	207-253	8-9	19-23	170-208	300-366	5-6	21-25	
	60°	2.6	131-160	252-308	13-16	17-21	110-134	306-374	8-10	22-27	
		3.0	125-153	237-290	8-9	18-22	115-141	314-383	6-7	23-29	
	70°	2.6	135-165	284-347	13-16	17-20	122-150	320-391	9-11	24-30	
		3.0	130-158	266-326	7-9	18-22	129-157	327-400	6-8	26-32	
	80°	2.6	140-171	320-391	13-16	16-20	134-164	333-407	11-13	27-33	
		3.0	134-164	300-367	7-9	17-21	141-172	341-417	7-9	28-35	
	90°	2.6	144-176	360-440	13-16	16-19	147-179	347-424	12-14	29-36	
		3.0	138-169	338-414	7-9	17-21	154-188	355-434	8-10	31-38	
	100°	2.6	149-182	405-495	13-15	15-19					
		3.0	143-174	381-465	7-9	16-20					

This chart shows approximate temperatures and pressures for a unit in good repair. The values shown are meant as a guide only and should not be used to estimate system charge. This chart assumes rated air flow and 80° d.b./67° w.b. entering air temperature in cooling, 70° d.b. entering air temperature in heating. Heating data at entering fluid temperatures below 50° assumes the use of antifreeze. Operation in shaded area requires the extended range option.

As a result of continuing research and development, specifications are subject to change without notice.

Operating Temperatures & Pressures, EC015-024

			OPERATING DATA								
			COOLING				HEATING				
MODEL	ENTERING WATER TEMP, °F	WATER FLOW GPM	SUCTION PRESSURE PSIG	DISCHARGE PRESSURE PSIG	WATER TEMP RISE, °F	AIR TEMP DROP, °F	SUCTION PRESSURE PSIG	DISCHARGE PRESSURE PSIG	WATER TEMP DROP, °F	AIR TEMP RISE, °F	
EC015	30°	2.8					74-90	244-299	3-4	13-15	
		3.8					78-95	251-306	2-3	13-16	
	40°	2.8	122-149	183-224	14-18	19-23	87-106	257-314	4-5	15-18	
		3.8	117-143	172-210	8-10	20-24	91-111	263-322	3-3	16-19	
	50°	2.8	131-160	214-261	14-18	18-22	164-201	269-329	5-6	17-20	
		3.8	126-154	201-245	8-10	19-24	173-211	276-337	3-4	18-22	
	60°	2.8	136-166	244-298	14-17	18-22	111-136	282-344	6-7	19-23	
		3.8	131-160	230-281	8-10	19-23	117-143	289-353	4-5	20-24	
	70°	2.8	141-172	275-336	14-17	17-21	124-152	294-360	7-8	21-25	
		3.8	135-165	258-316	8-10	18-22	131-160	302-369	5-6	22-27	
	80°	2.8	145-178	310-378	14-17	17-20	136-166	307-375	8-9	23-28	
		3.8	140-171	291-356	8-10	18-22	143-175	314-384	5-6	24-30	
	90°	2.8	150-183	349-426	14-17	16-20	149-182	319-390	8-10	25-30	
		3.8	144-176	328-401	8-9	17-21	156-191	327-400	6-7	26-32	
	100°	2.8	155-189	392-480	13-16	16-19					
		3.8	149-182	369-451	8-9	17-21					
	EC018	30°	3.0					65-80	282-344	6-7	14-17
			5.0					73-89	294-359	3-4	15-18
40°		3.0	121-148	184-225	17-21	18-22	80-98	299-365	7-9	16-20	
		5.0	117-143	167-204	10-13	19-23	89-108	311-380	4-5	17-21	
50°		3.0	123-151	222-271	17-20	17-21	95-116	315-385	9-11	19-23	
		5.0	119-145	202-247	10-12	18-23	105-128	329-402	5-7	20-24	
60°		3.0	125-153	260-318	16-19	17-21	109-133	332-406	11-13	21-26	
		5.0	120-147	237-289	10-12	18-22	121-148	346-423	6-8	22-27	
70°		3.0	127-155	298-365	15-19	17-20	124-151	349-427	12-15	23-28	
		5.0	122-149	271-331	9-11	18-21	138-168	364-444	7-9	25-30	
80°		3.0	129-158	336-411	14-18	16-20	138-169	366-447	14-17	26-31	
		5.0	124-152	306-374	9-11	17-21	154-188	381-466	8-10	27-33	
90°		3.0	131-160	374-458	14-17	16-19	153-187	383-468	16-16	28-34	
		5.0	126-154	340-416	8-10	17-20	170-208	399-487	9-12	29-36	
100°		3.0	133-162	413-504	13-16	15-19					
		5.0	128-156	375-458	8-10	16-20					
EC024		30°	5.0					72-87	296-361	5-6	21-25
			7.0					75-92	301-368	3-4	22-26
	40°	5.0	114-139	155-190	14-17	22-27	88-107	314-384	6-7	24-29	
		7.0	108-132	147-180	10-12	23-28	92-112	321-392	4-5	25-30	
	50°	5.0	116-142	192-234	13-16	21-26	104-127	333-407	7-9	27-33	
		7.0	111-135	182-222	9-12	22-27	109-133	340-415	5-6	28-34	
	60°	5.0	119-146	228-279	13-16	21-26	120-146	352-430	8-10	30-37	
		7.0	113-138	217-265	9-11	22-27	125-153	359-439	6-7	32-39	
	70°	5.0	122-149	264-323	13-15	20-25	136-166	371-453	9-12	33-41	
		7.0	116-142	251-307	9-11	21-26	142-174	378-462	7-8	35-43	
	80°	5.0	125-152	301-368	12-15	20-24	152-185	389-476	11-13	36-44	
		7.0	118-145	286-349	9-11	21-26	159-194	397-485	8-9	38-47	
	90°	5.0	127-156	337-412	12-15	19-24	168-205	408-499	12-15	39-48	
		7.0	121-148	320-392	9-10	20-25	176-215	416-509	8-10	41-51	
	100°	5.0	130-159	374-457	12-14	19-23					
		7.0	124-151	355-434	8-10	20-24					

This chart shows approximate temperatures and pressures for a unit in good repair. The values shown are meant as a guide only and should not be used to estimate system charge. This chart assumes rated air flow and 80° d.b./67° w.b. entering air temperature in cooling, 70° d.b. entering air temperature in heating. Heating data at entering fluid temperatures below 50° assumes the use of antifreeze. Operation in shaded area requires the extended range option.

As a result of continuing research and development, specifications are subject to change without notice.

Operating Temperatures & Pressures, EC030-042

			OPERATING DATA							
			COOLING				HEATING			
MODEL	ENTERING WATER TEMP, °F	WATER FLOW GPM	SUCTION PRESSURE PSIG	DISCHARGE PRESSURE PSIG	WATER TEMP RISE, °F	AIR TEMP DROP, °F	SUCTION PRESSURE PSIG	DISCHARGE PRESSURE PSIG	WATER TEMP DROP, °F	AIR TEMP RISE, °F
EC030	30°	3.5					73-89	266-325	5-6	15-18
		7.5					77-94	272-333	3-4	16-19
	40°	3.5	117-143	189-231	14-17	18-22	86-105	279-341	6-7	17-21
		7.5	112-137	178-217	8-9	19-24	90-110	286-350	4-5	18-22
	50°	3.5	126-154	221-270	14-17	18-21	162-198	293-358	7-8	20-24
		7.5	121-148	207-253	8-9	19-23	170-208	300-366	5-6	21-25
	60°	3.5	131-160	252-308	13-16	17-21	110-134	306-374	8-10	22-27
		7.5	125-153	237-290	8-9	18-22	115-141	314-383	6-7	23-29
	70°	3.5	135-165	284-347	13-16	17-20	122-150	320-391	9-11	24-30
		7.5	130-158	266-326	7-9	18-22	129-157	327-400	6-8	26-32
	80°	3.5	140-171	320-391	13-16	16-20	134-164	333-407	11-13	27-33
		7.5	134-164	300-367	7-9	17-21	141-172	341-417	7-9	28-35
90°	3.5	144-176	360-440	13-16	16-19	147-179	347-424	12-14	29-36	
	7.5	138-169	338-414	7-9	17-21	154-188	355-434	8-10	31-38	
100°	3.5	149-182	405-495	13-15	15-19					
	7.5	143-174	381-465	7-9	16-20					
EC036	30°	4.5					74-90	244-299	3-4	13-15
		9.0					78-95	251-306	2-3	13-16
	40°	4.5	122-149	183-224	14-18	19-23	87-106	257-314	4-5	15-18
		9.0	117-143	172-210	8-10	20-24	91-111	263-322	3-3	16-19
	50°	4.5	131-160	214-261	14-18	18-22	164-201	269-329	5-6	17-20
		9.0	126-154	201-245	8-10	19-24	173-211	276-337	3-4	18-22
	60°	4.5	136-166	244-298	14-17	18-22	111-136	282-344	6-7	19-23
		9.0	131-160	230-281	8-10	19-23	117-143	289-353	4-5	20-24
	70°	4.5	141-172	275-336	14-17	17-21	124-152	294-360	7-8	21-25
		9.0	135-165	258-316	8-10	18-22	131-160	302-369	5-6	22-27
	80°	4.5	145-178	310-378	14-17	17-20	136-166	307-375	8-9	23-28
		9.0	140-171	291-356	8-10	18-22	143-175	314-384	5-6	24-30
90°	4.5	150-183	349-426	14-17	16-20	149-182	319-390	8-10	25-30	
	9.0	144-176	328-401	8-9	17-21	156-191	327-400	6-7	26-32	
100°	4.5	155-189	392-480	13-16	16-19					
	9.0	149-182	369-451	8-9	17-21					
EC041 EC042	30°	6.0					64-78	248-303	5-6	15-18
		10.0					67-82	254-311	3-4	16-19
	40°	6.0	109-134	183-224	18-22	19-23	75-91	261-319	6-8	17-21
		10.0	105-128	172-210	10-12	20-25	79-96	267-327	4-5	18-23
	50°	6.0	118-144	214-261	18-22	19-23	142-173	273-334	8-10	20-24
		10.0	113-138	201-245	10-12	20-24	149-182	280-342	5-7	21-26
	60°	6.0	122-149	244-298	17-21	18-22	96-117	286-349	9-11	22-27
		10.0	117-143	230-281	10-12	19-24	101-123	293-358	6-8	24-29
	70°	6.0	126-154	275-336	17-21	18-22	107-131	299-365	11-13	25-30
		10.0	121-148	258-316	10-12	19-23	113-138	306-374	7-9	26-32
	80°	6.0	130-159	310-378	17-21	17-21	117-143	311-380	12-15	27-33
		10.0	125-153	291-356	10-12	18-22	123-151	319-390	8-10	29-35
90°	6.0	134-164	349-426	17-20	17-20	128-157	324-396	13-16	29-36	
	10.0	129-158	328-401	9-12	18-22	135-165	332-406	9-11	31-38	
100°	6.0	139-170	392-480	16-20	16-20					
	10.0	133-163	369-451	9-11	17-21					

This chart shows approximate temperatures and pressures for a unit in good repair. The values shown are meant as a guide only and should not be used to estimate system charge. This chart assumes rated air flow and 80° d.b./67° w.b. entering air temperature in cooling, 70° d.b. entering air temperature in heating. Heating data at entering fluid temperatures below 50° assumes the use of antifreeze. Operation in shaded area requires the extended range option.

As a result of continuing research and development, specifications are subject to change without notice.

Operating Temperatures & Pressures, EC048-070

			OPERATING DATA								
			COOLING				HEATING				
MODEL	ENTERING WATER TEMP, °F	WATER FLOW GPM	SUCTION PRESSURE PSIG	DISCHARGE PRESSURE PSIG	WATER TEMP RISE, °F	AIR TEMP DROP, °F	SUCTION PRESSURE PSIG	DISCHARGE PRESSURE PSIG	WATER TEMP DROP, °F	AIR TEMP RISE, °F	
EC048 EC051	30°	6.0					71-87	277-339	6-7	15-19	
		10.0					75-92	284-347	4-5	16-20	
	40°	6.0	118-144	194-237	21-25	19-23	84-102	291-356	7-9	18-22	
		10.0	113-138	182-223	12-14	20-24	88-108	299-365	5-6	19-23	
	50°	6.0	127-155	226-276	21-25	18-22	159-194	305-373	9-11	20-25	
		10.0	122-149	213-260	12-14	19-24	167-204	313-383	6-7	21-26	
	60°	6.0	131-160	259-316	21-25	18-22	108-132	320-391	10-13	23-28	
		10.0	126-154	243-297	12-14	19-23	113-138	328-400	7-9	24-29	
	70°	6.0	136-166	291-355	20-25	17-21	120-147	334-408	12-15	25-31	
		10.0	130-159	273-334	12-14	18-22	126-154	342-418	8-10	27-32	
	80°	6.0	140-171	328-401	20-24	17-20	131-161	348-425	14-17	27-34	
		10.0	135-165	308-377	11-14	18-22	138-169	356-436	9-11	29-36	
	90°	6.0	145-177	369-451	20-24	16-20	144-176	362-442	15-18	30-37	
		10.0	139-170	347-424	11-14	17-21	151-185	371-453	10-12	32-39	
	100°	6.0	149-183	415-508	19-24	16-19					
		10.0	143-175	391-477	11-14	17-21					
	EC060 EC061	30°	8.0					68-84	256-313	5-7	19-23
			12.0					73-89	261-319	4-5	20-25
40°		8.0	113-138	173-212	18-22	19-23	81-99	277-339	7-8	22-26	
		12.0	110-134	162-198	12-14	20-24	86-105	283-346	5-6	23-28	
50°		8.0	116-142	207-253	17-21	19-23	93-114	299-365	8-9	24-29	
		12.0	112-137	193-236	12-14	19-24	99-121	305-373	6-7	25-31	
60°		8.0	118-145	240-293	17-21	18-23	106-129	321-392	9-11	26-32	
		12.0	115-140	224-274	11-14	19-23	113-138	327-400	7-8	28-34	
70°		8.0	121-148	273-334	17-21	18-22	118-145	342-418	10-12	29-35	
		12.0	117-143	255-312	11-14	19-23	126-154	349-427	8-9	30-37	
80°		8.0	123-151	307-375	16-20	18-22	131-160	364-444	11-14	31-38	
		12.0	120-146	287-350	11-13	19-23	139-170	371-454	8-10	33-40	
90°		8.0	126-154	340-416	16-20	18-22	143-175	385-471	12-15	33-41	
		12.0	122-149	318-388	11-13	18-22	152-186	393-480	9-11	35-43	
100°		8.0	128-157	373-456	16-19	17-21					
		12.0	125-152	349-426	11-13	18-22					
EC070		30°	12.0					68-84	256-313	5-7	19-23
			16.0					73-89	261-319	4-5	20-25
	40°	12.0	117-143	182-222	15-19	21-26	81-99	277-339	7-8	22-26	
		16.0	114-139	170-208	11-14	22-27	86-105	283-346	5-6	23-28	
	50°	12.0	120-147	215-263	15-18	20-25	93-114	299-365	8-9	24-29	
		16.0	117-143	201-246	11-14	21-26	99-121	305-373	6-7	25-31	
	60°	12.0	123-150	248-304	14-17	20-24	106-129	321-392	9-11	26-32	
		16.0	119-146	232-284	11-13	21-25	113-138	327-400	7-8	28-34	
	70°	12.0	126-154	282-344	14-17	19-24	118-145	342-418	10-12	29-35	
		16.0	122-149	263-322	10-13	20-25	126-154	349-427	8-9	30-37	
	80°	12.0	129-157	315-385	13-16	19-23	131-160	364-444	11-14	31-38	
		16.0	125-153	294-360	10-12	19-24	139-170	371-454	8-10	33-40	
	90°	12.0	132-161	348-426	13-16	18-22	143-175	385-471	12-15	33-41	
		16.0	128-156	326-398	10-12	19-23	152-186	393-480	9-11	35-43	
	100°	12.0	134-164	382-466	12-15	17-21					
		16.0	131-160	357-436	9-11	18-22					

This chart shows approximate temperatures and pressures for a unit in good repair. The values shown are meant as a guide only and should not be used to estimate system charge. This chart assumes rated air flow and 80° d.b./67° w.b. entering air temperature in cooling, 70° d.b. entering air temperature in heating. Heating data at entering fluid temperatures below 50° assumes the use of antifreeze. Operation in shaded area requires the extended range option.

As a result of continuing research and development, specifications are subject to change without notice.

Operating Temperatures & Pressures, EC072-120

			OPERATING DATA								
			COOLING				HEATING				
MODEL	ENTERING WATER TEMP, °F	WATER FLOW GPM	SUCTION PRESSURE PSIG	DISCHARGE PRESSURE PSIG	WATER TEMP RISE, °F	AIR TEMP DROP, °F	SUCTION PRESSURE PSIG	DISCHARGE PRESSURE PSIG	WATER TEMP DROP, °F	AIR TEMP RISE, °F	
EC072	30°	10.0					65-80	282-344	6-7	14-17	
		16.0					73-89	294-359	3-4	15-18	
	40°	10.0	121-148	184-225	17-21	18-22	80-98	299-365	7-9	16-20	
		16.0	117-143	167-204	10-13	19-23	89-108	311-380	4-5	17-21	
	50°	10.0	123-151	222-271	17-20	17-21	95-116	315-385	9-11	19-23	
		16.0	119-145	202-247	10-12	18-23	105-128	329-402	5-7	20-24	
	60°	10.0	125-153	260-318	16-19	17-21	109-133	332-406	11-13	21-26	
		16.0	120-147	237-289	10-12	18-22	121-148	346-423	6-8	22-27	
	70°	10.0	127-155	298-365	15-19	17-20	124-151	349-427	12-15	23-28	
		16.0	122-149	271-331	9-11	18-21	138-168	364-444	7-9	25-30	
	80°	10.0	129-158	336-411	14-18	16-20	138-169	366-447	14-17	26-31	
		16.0	124-152	306-374	9-11	17-21	154-188	381-466	8-10	27-33	
	90°	10.0	131-160	374-458	14-17	16-19	153-187	383-468	16-19	28-34	
		16.0	126-154	340-416	8-10	17-20	170-208	399-487	9-12	29-36	
	100°	10.0	133-162	413-504	13-16	15-19					
		16.0	128-156	375-458	8-10	16-20					
	EC096	30°	13.0					72-87	296-361	5-6	21-25
			22.0					75-92	301-368	3-4	22-26
40°		13.0	114-139	155-190	14-17	22-27	88-107	314-384	6-7	24-29	
		22.0	108-132	147-180	10-12	23-28	92-112	321-392	4-5	25-30	
50°		13.0	116-142	192-234	13-16	21-26	104-127	333-407	7-9	27-33	
		22.0	111-135	182-222	9-12	22-27	109-133	340-415	5-6	28-34	
60°		13.0	119-146	228-279	13-16	21-26	120-146	352-430	8-10	30-37	
		22.0	113-138	217-265	9-11	22-27	125-153	359-439	6-7	32-39	
70°		13.0	122-149	264-323	13-15	20-25	136-166	371-453	9-12	33-41	
		22.0	116-142	251-307	9-11	21-26	142-174	378-462	7-8	35-43	
80°		13.0	125-152	301-368	12-15	20-24	152-185	389-476	11-13	36-44	
		22.0	118-145	286-349	9-11	21-26	159-194	397-485	8-9	38-47	
90°		13.0	127-156	337-412	12-15	19-24	168-205	408-499	12-15	39-48	
		22.0	121-148	320-392	9-10	20-25	176-215	416-509	8-10	41-51	
100°		13.0	130-159	374-457	12-14	19-23					
		22.0	124-151	355-434	8-10	20-24					
EC120		30°	16.0					73-89	266-325	5-6	15-18
			32.0					77-94	272-333	3-4	16-19
	40°	16.0	117-143	189-231	14-17	18-22	86-105	279-341	6-7	17-21	
		32.0	112-137	178-217	8-9	19-24	90-110	286-350	4-5	18-22	
	50°	16.0	126-154	221-270	14-17	18-21	162-198	293-358	7-8	20-24	
		32.0	121-148	207-253	8-9	19-23	170-208	300-366	5-6	21-25	
	60°	16.0	131-160	252-308	13-16	17-21	110-134	306-374	8-10	22-27	
		32.0	125-153	237-290	8-9	18-22	115-141	314-383	6-7	23-29	
	70°	16.0	135-165	284-347	13-16	17-20	122-150	320-391	9-11	24-30	
		32.0	130-158	266-326	7-9	18-22	129-157	327-400	6-8	26-32	
	80°	16.0	140-171	320-391	13-16	16-20	134-164	333-407	11-13	27-33	
		32.0	134-164	300-367	7-9	17-21	141-172	341-417	7-9	28-35	
	90°	16.0	144-176	360-440	13-16	16-19	147-179	347-424	12-14	29-36	
		32.0	138-169	338-414	7-9	17-21	154-188	355-434	8-10	31-38	
	100°	16.0	149-182	405-495	13-15	15-19					
		32.0	143-174	381-465	7-9	16-20					

This chart shows approximate temperatures and pressures for a unit in good repair. The values shown are meant as a guide only and should not be used to estimate system charge. This chart assumes rated air flow and 80° d.b./67° w.b. entering air temperature in cooling, 70° d.b. entering air temperature in heating. Heating data at entering fluid temperatures below 50° assumes the use of antifreeze. Operation in shaded area requires the extended range option.

As a result of continuing research and development, specifications are subject to change without notice.

Operating Temperatures & Pressures, EC150-210

			OPERATING DATA								
			COOLING				HEATING				
MODEL	ENTERING WATER TEMP, °F	WATER FLOW GPM	SUCTION PRESSURE PSIG	DISCHARGE PRESSURE PSIG	WATER TEMP RISE, °F	AIR TEMP DROP, °F	SUCTION PRESSURE PSIG	DISCHARGE PRESSURE PSIG	WATER TEMP DROP, °F	AIR TEMP RISE, °F	
EC150	30°	22.0					74-90	244-299	3-4	13-15	
		38.0					78-95	251-306	2-3	13-16	
	40°	22.0	122-149	183-224	14-18	19-23	87-106	257-314	4-5	15-18	
		38.0	117-143	172-210	8-10	20-24	91-111	263-322	3-3	16-19	
	50°	22.0	131-160	214-261	14-18	18-22	164-201	269-329	5-6	17-20	
		38.0	126-154	201-245	8-10	19-24	173-211	276-337	3-4	18-22	
	60°	22.0	136-166	244-298	14-17	18-22	111-136	282-344	6-7	19-23	
		38.0	131-160	230-281	8-10	19-23	117-143	289-353	4-5	20-24	
	70°	22.0	141-172	275-336	14-17	17-21	124-152	294-360	7-8	21-25	
		38.0	135-165	258-316	8-10	18-22	131-160	302-369	5-6	22-27	
	80°	22.0	145-178	310-378	14-17	17-20	136-166	307-375	8-9	23-28	
		38.0	140-171	291-356	8-10	18-22	143-175	314-384	5-6	24-30	
	90°	22.0	150-183	349-426	14-17	16-19	149-182	319-390	8-10	25-30	
		38.0	144-176	328-401	8-9	17-21	156-191	327-400	6-7	26-32	
	100°	22.0	155-189	392-480	13-16	16-19					
		38.0	149-182	369-451	8-9	17-21					
	EC180	30°	25.0					64-78	248-303	5-6	15-18
			45.0					67-82	254-311	3-4	16-19
40°		25.0	109-134	183-224	18-22	19-23	75-91	261-319	6-8	17-21	
		45.0	105-128	172-210	10-12	20-25	79-96	267-327	4-5	18-23	
50°		25.0	118-144	214-261	18-22	19-23	142-173	273-334	8-10	20-24	
		45.0	113-138	201-245	10-12	20-24	149-182	280-342	5-7	21-26	
60°		25.0	122-149	244-298	17-21	18-22	96-117	286-349	9-11	22-27	
		45.0	117-143	230-281	10-12	19-24	101-123	293-358	6-8	24-29	
70°		25.0	126-154	275-336	17-21	18-22	107-131	299-365	11-13	25-30	
		45.0	121-148	258-316	10-12	19-23	113-138	306-374	7-9	26-32	
80°		25.0	130-159	310-378	17-21	17-21	117-143	311-380	12-15	27-33	
		45.0	125-153	291-356	10-12	18-22	123-151	319-390	8-10	29-35	
90°		25.0	134-164	349-426	17-20	17-20	128-157	324-396	13-16	29-36	
		45.0	129-158	328-401	9-12	18-22	135-165	332-406	9-11	31-38	
100°		25.0	139-170	392-480	16-20	16-20					
		45.0	133-163	369-451	9-11	17-21					
EC210		30°	28.0					71-87	277-339	6-7	15-19
			52.0					75-92	284-347	4-5	16-20
	40°	28.0	118-144	194-237	21-25	19-23	84-102	291-356	7-9	18-22	
		52.0	113-138	182-223	12-14	20-24	88-108	299-365	5-6	19-23	
	50°	28.0	127-155	226-276	21-25	18-22	159-194	305-373	9-11	20-25	
		52.0	122-149	213-260	12-14	19-24	167-204	313-383	6-7	21-26	
	60°	28.0	131-160	259-316	21-25	18-22	108-132	320-391	10-13	23-28	
		52.0	126-154	243-297	12-14	19-23	113-138	328-400	7-9	24-29	
	70°	28.0	136-166	291-355	20-25	17-21	120-147	334-408	12-15	25-31	
		52.0	130-159	273-334	12-14	18-22	126-154	342-418	8-10	27-32	
	80°	28.0	140-171	328-401	20-24	17-20	131-161	348-425	14-17	27-34	
		52.0	135-165	308-377	11-14	18-22	138-169	356-436	9-11	29-36	
	90°	28.0	145-177	369-451	20-24	16-20	144-176	362-442	15-18	30-37	
		52.0	139-170	347-424	11-14	17-21	151-185	371-453	10-12	32-39	
	100°	28.0	149-183	415-508	19-24	16-19					
		52.0	143-175	391-477	11-14	17-21					

This chart shows approximate temperatures and pressures for a unit in good repair. The values shown are meant as a guide only and should not be used to estimate system charge. This chart assumes rated air flow and 80° d.b./67° w.b. entering air temperature in cooling, 70° d.b. entering air temperature in heating. Heating data at entering fluid temperatures below 50° assumes the use of antifreeze. Operation in shaded area requires the extended range option.

As a result of continuing research and development, specifications are subject to change without notice.

Operating Temperatures & Pressures, EC240-360

			OPERATING DATA								
			COOLING				HEATING				
MODEL	ENTERING WATER TEMP, °F	WATER FLOW GPM	SUCTION PRESSURE PSIG	DISCHARGE PRESSURE PSIG	WATER TEMP RISE, °F	AIR TEMP DROP, °F	SUCTION PRESSURE PSIG	DISCHARGE PRESSURE PSIG	WATER TEMP DROP, °F	AIR TEMP RISE, °F	
EC240	30°	32.0					68-84	256-313	5-7	19-23	
		64.0					73-89	261-319	4-5	20-25	
	40°	32.0	113-138	172-210	18-22	19-23	81-99	277-339	7-8	22-26	
		64.0	110-134	161-196	12-14	20-24	86-105	283-346	5-6	23-28	
	50°	32.0	116-142	206-252	17-21	19-23	93-114	299-365	8-9	24-29	
		64.0	112-137	193-236	12-14	19-24	99-121	305-373	6-7	25-31	
	60°	32.0	118-145	241-294	17-21	18-23	106-129	321-392	9-11	26-32	
		64.0	115-140	225-275	11-14	19-23	113-138	327-400	7-8	28-34	
	70°	32.0	121-148	275-336	17-21	18-22	118-145	342-418	10-12	29-35	
		64.0	117-143	257-314	11-14	19-23	126-154	349-427	8-9	30-37	
	80°	32.0	123-151	309-378	16-20	18-22	131-160	364-444	11-14	31-38	
		64.0	120-146	289-353	11-13	19-23	139-170	371-454	8-10	33-40	
	90°	32.0	126-154	344-420	16-20	18-22	143-175	385-471	12-15	33-41	
		64.0	122-149	321-392	11-13	18-22	152-186	393-480	9-11	35-43	
	100°	32.0	128-157	378-462	16-19	17-21					
		64.0	125-152	353-432	11-13	18-22					
	EC300	30°	45.0					68-84	256-313	5-7	19-23
			75.0					73-89	261-319	4-5	20-25
40°		45.0	117-143	210-256	15-19	21-26	81-99	277-339	7-8	22-26	
		75.0	114-139	196-239	11-14	22-27	86-105	283-346	5-6	23-28	
50°		45.0	120-147	243-297	15-18	20-25	93-114	299-365	8-9	24-29	
		75.0	117-143	227-277	11-14	21-26	99-121	305-373	6-7	25-31	
60°		45.0	123-150	276-337	14-17	20-24	106-129	321-392	9-11	26-32	
		75.0	119-146	258-315	11-13	21-25	113-138	327-400	7-8	28-34	
70°		45.0	126-154	309-378	14-17	19-24	118-145	342-418	10-12	29-35	
		75.0	122-149	289-353	10-13	20-25	126-154	349-427	8-9	30-37	
80°		45.0	129-157	343-419	13-16	19-23	131-160	364-444	11-14	31-38	
		75.0	125-153	320-391	10-12	19-24	139-170	371-454	8-10	33-40	
90°		45.0	132-161	376-459	13-16	18-22	143-175	385-471	12-15	33-41	
		75.0	128-156	351-429	10-12	19-23	152-186	393-480	9-11	35-43	
100°		45.0	134-164	409-500	12-15	17-21					
		75.0	131-160	382-467	9-11	18-22					
EC360		30°	50.0					65-80	282-344	6-7	14-17
			90.0					73-89	294-359	3-4	15-18
	40°	50.0	121-148	184-225	17-21	18-22	80-98	299-365	7-9	16-20	
		90.0	117-143	167-204	10-13	19-23	89-108	311-380	4-5	17-21	
	50°	50.0	123-151	222-271	17-20	17-21	95-116	315-385	9-11	19-23	
		90.0	119-145	202-247	10-12	18-23	105-128	329-402	5-7	20-24	
	60°	50.0	125-153	260-318	16-19	17-21	109-133	332-406	11-13	21-26	
		90.0	120-147	237-289	10-12	18-22	121-148	346-423	6-8	22-27	
	70°	50.0	127-155	298-365	15-19	17-20	124-151	349-427	12-15	23-28	
		90.0	122-149	271-331	9-11	18-21	138-168	364-444	7-9	25-30	
	80°	50.0	129-158	336-411	14-18	16-20	138-169	366-447	14-17	26-31	
		90.0	124-152	306-374	9-11	17-21	154-188	381-466	8-10	27-33	
	90°	50.0	131-160	374-458	14-17	16-19	153-187	383-468	16-19	28-34	
		90.0	126-154	340-416	8-10	17-20	170-208	399-487	9-12	29-36	
	100°	50.0	133-162	413-504	13-16	15-19					
		90.0	128-156	375-458	8-10	16-20					

This chart shows approximate temperatures and pressures for a unit in good repair. The values shown are meant as a guide only and should not be used to estimate system charge. This chart assumes rated air flow and 80° d.b./67° w.b. entering air temperature in cooling, 70° d.b. entering air temperature in heating. Heating data at entering fluid temperatures below 50° assumes the use of antifreeze. Operation in shaded area requires the extended range option.

As a result of continuing research and development, specifications are subject to change without notice.

UNIT CHECK-OUT SHEET

Customer Data

Customer Name _____ Date _____
 Address _____
 Phone _____ Unit Number _____

Unit Nameplate Data

Unit Make _____
 Model Number _____ Serial Number _____
 Refrigerant Charge (oz) _____
 Compressor: RLA _____ LRA _____
 Blower Motor: FLA (or NPA) _____ HP _____
 Maximum Fuse Size (Amps) _____
 Minimum Circuit Ampacity (Amps) _____

Operating Conditions

	Cooling Mode	Heating Mode
Entering / Leaving Air Temp	_____ / _____	_____ / _____
Entering Air Measured at:	_____	_____
Leaving Air Measured at:	_____	_____
Entering / Leaving Fluid Temp	_____ / _____	_____ / _____
Fluid Flow (gpm)	_____	_____
Fluid Side Pressure Drop	_____	_____
Suction / Discharge Pressure (psig)	_____ / _____	_____ / _____
Suction / Discharge Temp	_____ / _____	_____ / _____
Suction Superheat	_____	_____
Entering TXV / Cap Tube Temp	_____	_____
Liquid Subcooling	_____	_____
Compressor Volts / Amps	_____ / _____	_____ / _____
Blower Motor Volts / Amps	_____ / _____	_____ / _____

Auxiliary Heat

Unit Make _____
 Model Number _____ Serial Number _____
 Max Fuse Size (Amps) _____
 Volts / Amps _____ / _____
 Entering Air Temperature _____
 Leaving Air Temperature _____

TROUBLE SHOOTING

PROBLEM	POSSIBLE CAUSE	CHECKS AND CORRECTIONS
ENTIRE UNIT DOES NOT RUN	Power supply off	Apply power, close disconnect
	Blown fuse	Replace fuse or reset circuit breaker. Check for correct fuses.
	Voltage supply low	If voltage is below minimum voltage specified on unit data plate, contact local power company.
	Thermostat	Set the fan to "ON", the fan should run. Set thermostat to "COOL" and lowest temperature setting, the unit should run in the cooling mode (reversing valve energized). Set unit to "HEAT" and the highest temperature setting, the unit should run in the heating mode. If neither the blower or compressor run in all three cases, the thermostat could be miswired or faulty. To ensure miswired or faulty thermostat verify 24 volts is available on the condensing section low voltage terminal strip between "R" and "C", "Y" and "C", and "O" and "C". If the blower does not operate, verify 24 volts between terminals "G" and "C" in the air handler. Replace the thermostat if defective.
BLOWER OPERATES BUT COMPRESSOR DOES NOT	Thermostat	Check setting, calibration, and wiring.
	Wiring	Check for loose or broken wires at compressor, capacitor, or contactor.
	Safety controls	Check UPM board red default L.E.D. for Blink Code
	Compressor overload open	If the compressor is cool and the overload will not reset, replace compressor.
	Compressor motor grounded	Internal winding grounded to the compressor shell. Replace compressor. If compressor burnout, install suction filter dryer.
	Compressor windings open	After compressor has cooled, check continuity of the compressor windings. If the windings are open, replace the compressor.
UNIT OFF ON HIGH PRESSURE CONTROL	Discharge pressure too high	In "COOLING" mode: Lack of or inadequate water flow. Entering water temperature too warm. Scaled or plugged condenser. In "HEATING" mode: Lack of or inadequate air flow. Blower inoperative, clogged filter or restrictions in ductwork.
	Refrigerant charge	The unit is overcharged with refrigerant. Reclaim refrigerant, evacuate and recharge with factory recommended charge.
	High pressure	Check for defective or improperly calibrated high pressure switch.
UNIT OFF ON LOW PRESSURE CONTROL	Suction pressure too low	In "COOLING" mode: Lack of or inadequate air flow. Entering air temperature too cold. Blower inoperative, clogged filter, or restrictions in ductwork. In "HEATING" mode: Lack of or inadequate water flow. Entering water temperature too cold. Scaled or plugged condenser.
	Refrigerant charge	The unit is low on refrigerant. Check for refrigerant leak, repair, evacuate and recharge with factory recommended charge.
	Low pressure switch	Check for defective or improperly calibrated low pressure switch.
UNIT SHORT CYCLES	Unit oversized	Recalculate heating and or cooling loads.
	Thermostat	Thermostat installed near a supply air grill, relocate thermostat. Readjust heat anticipator.
	Wiring and controls	Loose connections in the wiring or a defective compressor contactor.
INSUFFICIENT COOLING OR HEATING	Unit undersized	Recalculate heating and or cooling loads. If excessive, possibly adding insulation and shading will rectify the problem.
	Loss of conditioned air by leaks	Check for leaks in duct work or introduction of ambient air through doors or windows.
	Airflow	Lack of adequate air flow or improper distribution of air. Replace dirty filter.
	Refrigerant charge	Low on refrigerant charge causing inefficient operation.
	Compressor	Check for defective compressor. If discharge is too low and suction pressure is too high, compressor is not pumping properly. Replace compressor.
	Reversing valve	Defective reversing valve creating bypass of refrigerant from discharge to suction side of compressor. Replace reversing valve.
	Operating pressures	Compare unit operating pressures to the pressure / temperature chart for the unit.
	TXV/Capillary Tube	Check for possible restriction or defect. Replace if necessary.
Moisture, noncondensables	The refrigerant system may be contaminated with moisture or noncondensables. Reclaim refrigerant, evacuate and recharge with factory recommended charge. Note: a liquid line dryer may be required.	

NOTES:

