

COMMERCIAL | WATER²AIR | EC LARGE SERIES

Reinventing Energy Efficiency



Key Features

Standard

- Coated Air Coils
- Stainless Steel Drain Pan
- Filter Drier
- TXV Valve
- Service Connections
- R410-A Refrigerant
- Coaxial Heat Exchanger Copper
- Blower Housing
- Unit Protection Module 2

- Scroll Compressor
- 4-Way Reversing Valve

Optional

- Four Sided Filter Rack
- Hot Gas Bypass
- Hot Gas Reheat
- Coaxial Heat Exchanger Cupronickel
- DDC Controls
- Geothermal
- Compressor Blanket



EC^{LARGE} SERIES

High Efficiency

FHP's EC Large Series is equipped with two-stage compressor power that brings high efficiency into any commercial project. If you are looking for more than a 6 tons unit, FHP offers the right size for your project up to 30 tons in various configurations to fit your needs. When equipped with the "Extended Range Option", the unit is suitable for geothermal applications.

Quiet Operation

The EC Large Series is engineered to be a very quiet unit for your commercial project. Features like the compressor blanket keep sound to an absolute minimum.

Environmentally Friendly

These highly efficient units not only will reduce your operating costs but play their part in reducing CO₂ emissions, a leading cause of global warming.

Quality

Rigorous factory testing virtually guarantees no hassle from the start while FHP's almost 40 years of experience in designing heat pumps for commercial applications is your assurance of a state of the art quality product. FHP's ISO 9001:2000 certified facilities provide consistent quality in every unit we build.

MODEL	DIMENSIONS					
	VERTICAL			HORIZONTAL		
	A (width)	B (depth)	C (height)	A (width)	B (depth)	C (height)
EC072	42.00	32.00	62.00	38.00	78.00	21.50
EC096	42.00	32.00	62.00	38.00	78.00	21.50
EC120	42.00	32.00	62.00	38.00	78.00	21.50
EC150	N/A	N/A	N/A	42.00	82.00	25.50
EC151	52.50	32.00	70.00	N/A	N/A	N/A
EC180	N/A	N/A	N/A	60.25	120.50	28.00
EC181	52.50	32.00	70.00	N/A	N/A	N/A
EC210	80.00	32.00	62.00	N/A	N/A	N/A
EC240	80.00	32.00	66.50	N/A	N/A	N/A
EC242	N/A	N/A	N/A	60.25	120.50	38.75
EC300	80.00	32.00	66.50	N/A	N/A	N/A
EC360	80.00	32.00	86.50	N/A	N/A	N/A

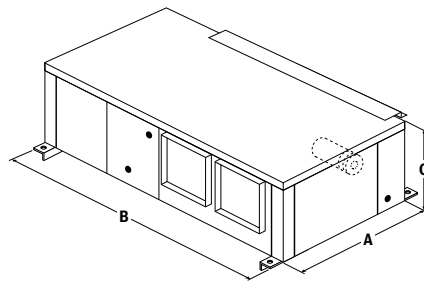

Vertical
EC 072 - 181

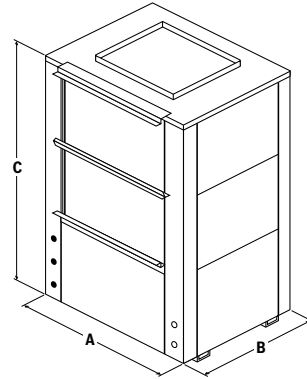

EC
LARGE
SERIES

Vertical
EC 210-360

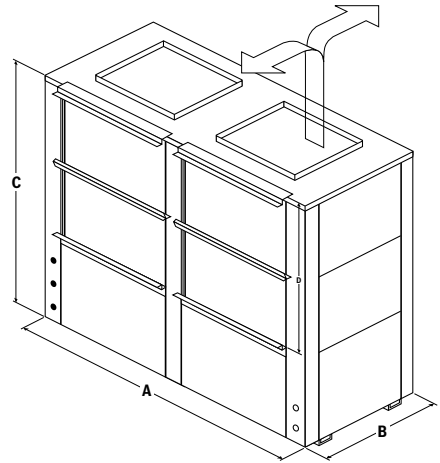

Horizontal
EC 072 - 242

MODEL	ARI / ISO 13256-1 PERFORMANCE DATA											
	ENTERING WATER TEMPERATURES											
	Water Loop (WLHP)				Ground Water (GWHP)				Ground Loop (GLHP)			
	86°F		68°F		59°F		50°F		77°F		32°F	
	CAPACITY AND EFFICIENCY DATA											
	COOLING CAPACITY	EER	HEATING CAPACITY	COP	COOLING CAPACITY	EER	HEATING CAPACITY	COP	COOLING CAPACITY	EER	HEATING CAPACITY	COP
EC072 *	72,000	13.0	92,000	4.5	80,400	18.6	72,400	3.8	75,600	14.2	54,800	3.2
EC096 *	96,000	14.0	116,000	4.8	116,000	20.6	93,200	4.2	104,000	15.4	73,600	3.5
EC120 *	124,000	13.2	158,000	4.4	134,000	18.3	123,000	3.9	127,000	14.7	100,000	3.2
EC150	157,000	16.0	181,000	5.6	185,000	24.0	140,000	5.0	166,000	17.9	107,000	4.2
EC151	147,000	16.0	181,000	5.6	175,000	24.0	140,000	5.0	155,000	17.9	107,000	4.2
EC180	182,000	14.2	204,000	5.0	195,000	20.0	156,000	4.2	185,000	15.4	118,000	3.5
EC181	170,000	14.2	204,000	5.0	185,000	20.0	156,000	4.2	175,000	15.4	118,000	3.5
EC210	220,000	14.6	270,000	5.1	292,000	22.5	204,000	4.5	250,000	17.2	152,000	3.9
EC240	248,000	14.4	315,000	5.0	310,000	21.1	250,000	4.5	275,000	16.0	180,000	3.9
EC242	248,000	14.4	315,000	5.0	310,000	21.1	250,000	4.5	275,000	16.0	180,000	3.9
EC300	295,000	13.0	376,000	4.2	365,000	18.8	300,000	3.8	318,000	14.0	222,000	3.2
EC360	386,000	14.8	435,000	4.4	472,000	22.0	342,000	4.0	412,000	16.4	252,000	3.3

*AHRI Certified



601 N.W. 65th Court, Ft. Lauderdale, FL 33309
 Phone: 954-776-5471 | Fax: 954-776-5529
 www.boschtaxcredit.com | www.fhp-mfg.com

