

Indoor & outdoor models available

Horizontal or vertical flue discharge

Pre-engineered solutions



COMMERCIAL CONTINUOUS FLOW incl. **COMMPAK®** & **MULTIPAK®**

THE RANGE

Rheem is the biggest name in commercial and industrial water heating. Our Commercial Continuous Flow Water Heater (CFWH) range meets all the demands expected of Rheem products – from luxury homes to the largest commercial hot water application imaginable.

Commpak®

- Pre-engineered and assembled for ease of installation
- Compact wall or floor mount design
- Mains pressure performance without the use of tanks
- Suitable for small to medium sized applications

Commpak Plus®

- Engineered to meet customer requirements
- Dual pumps provide back up and redundancy
- Staged system operation
- Suitable for large applications

Multipak®

- Plug and Play – simply connects to the plumbing services
- Staged delivery on demand
- 50°C and up to 82°C models
- Left or right hand plumbing

Individual Continuous Flow

- Indoor and outdoor models
- 50°C limited models
- Commercial models up to 82°C
- Full range of accessories including Rheem flue components



OUTDOOR MODEL

INDOOR MODEL



Commpak Plus®

COMMERCIAL CONTINUOUS FLOW WATER HEATING

Rheem Commercial CFWH have unique features that provide added safety and functionality.

- Up to 5.8 Star energy rating water heater²⁰
- Q-factor[®] provides constant temperature at the outlet rapidly
- Unique Flame Safe[®] technology detects heat exchanger faults and shuts the system down
- Frost protection is supplied standard
- Backed by Rheem's nationwide service network and a 5 year commercial warranty²¹
- Suitable from the smallest to the largest hot water demand applications using the Multipak[®] and Commpak[®] platforms
- 50°C models certified to AS3498 negate the need for further tempering²². 82°C models are suitable for sanitising applications
- EZ Link[®] two units together with a Deluxe Kitchen Temperature Controller for greater capacity. Max 60°C
- The range includes outdoor models and indoor models with Rheem supplied flue kits. Models are available for use on either natural or propane gas

CFWH TECHNICAL DATA

RHEEM COMMERCIAL CONTINUOUS FLOW		OUTDOOR MODELS		INDOOR MODELS	
Model		872027	876027	862027	866027
Delivery Temperature		up to 82°C	50°C per AS3498	up to 82°C	50°C per AS3498
Input	MJ/h	205	205	205	205
Output	kW	46	46	46	46
Gas Energy Rating	Stars	5.8	5.8	5.6	5.6
Flow Rate @ 25°C Rise	L/min	27	27	27	27
Minimum Flow Rate	L/min	2	2	2	2
Dimensions					
Height	mm	600	600	650	650
Width	mm	350	350	350	350
Depth	mm	225	225	250	250
Frost Protection		yes	yes	yes	yes
Approximate Weight	kg	23	23	23	23
Inlet/Outlet Connections	BSPM	R ³ / ₄ /20	R ³ / ₄ /20	R ³ / ₄ /20	R ³ / ₄ /20
Gas Connection	BSPM	R ³ / ₄ /20	R ³ / ₄ /20	R ³ / ₄ /20	R ³ / ₄ /20
Water Supply Pressure					
Maximum	kPa	1000	1000	1000	1000
Minimum	kPa	140	140	140	140
Gas Supply Pressure Range					
Natural Gas	kPa	1.13 – 3.5	1.13 – 3.5	1.13 – 3.5	1.13 – 3.5
Propane	kPa	2.75 – 3.5	2.75 – 3.5	2.75 – 3.5	2.75 – 3.5
Temperature Settings	°C	38, 40, 42, 43, 45, 50, 55, 60, 65, 70, 75, 82	38, 40, 42, 43, 45, 50	38, 40, 42, 43, 45, 50, 55, 60, 65, 70, 75, 82	38, 40, 42, 43, 45, 50
Factory Set Temperature	°C	60	50	60	50
Co-Axial Flue Specification					
Inner – Material/Diameter	mm	NA	NA	316SS/75	316SS/75
Outer – Material/Diameter	mm	NA	NA	Aluminised Steel/125	Aluminised Steel/125
Maximum Flue Run		NA	NA	9m & 3 x 90° Bends	9m & 3 x 90° Bends
Accessories					
Pipe Cover		299830	299830	NA	NA
Recess Box		299831	299831	NA	NA
Security Bracket		299868	299868	299868	299868
Security Cage		299867	299867	NA	NA
EZ Link [®] Kit Max 60°C (Deluxe Kitchen Controller not included)		290141	290141	290141	290141
Deluxe Temperature Controllers (Max 60°C)					
Kitchen		299858	299858	299858	299858
Bathroom 1		299859	299859	299859	299859
Bathroom 2		299860	299860	299860	299860

²⁰ Outdoor Model.

²¹ Warranty*: 5 years heat exchanger with a thermostat setting not exceeding 75°C, 12 months parts and labour. 12 months heat exchanger warranty when used with a thermostat

setting exceeding 75°C.

*Conditions apply: For full terms and conditions please contact Rheem or see Owner's Guide and Installation Instructions, available at www.rheem.com.au

²² 50°C limited systems are suitable for dead leg applications only. Further tempering may be required. Consult AS3500.4 for details.

COMMERCIAL CONTINUOUS FLOW

incl. **COMMPAK®** & **MULTIPAK®**

INDOOR INSTALLATION

The Rheem 27 CFWH is available in models suitable for indoor installation. The flue system is room sealed coaxial design manufactured from high grade stainless steel inner and aluminised steel outer.

The maximum flue length with no bends is 13.5m. Reduce the maximum length by 1.5m for every 90° bend and reduce the maximum length by 0.75m for every 45° bend.

Separate ventilation for combustion is not required as the air for combustion is supplied in the flue outer. The flue system can be installed with zero clearances from combustible materials. Flue termination must comply with the requirements of AS/NZS 5601.1.



RHEEM CONTINUOUS FLOW FLUE SYSTEM

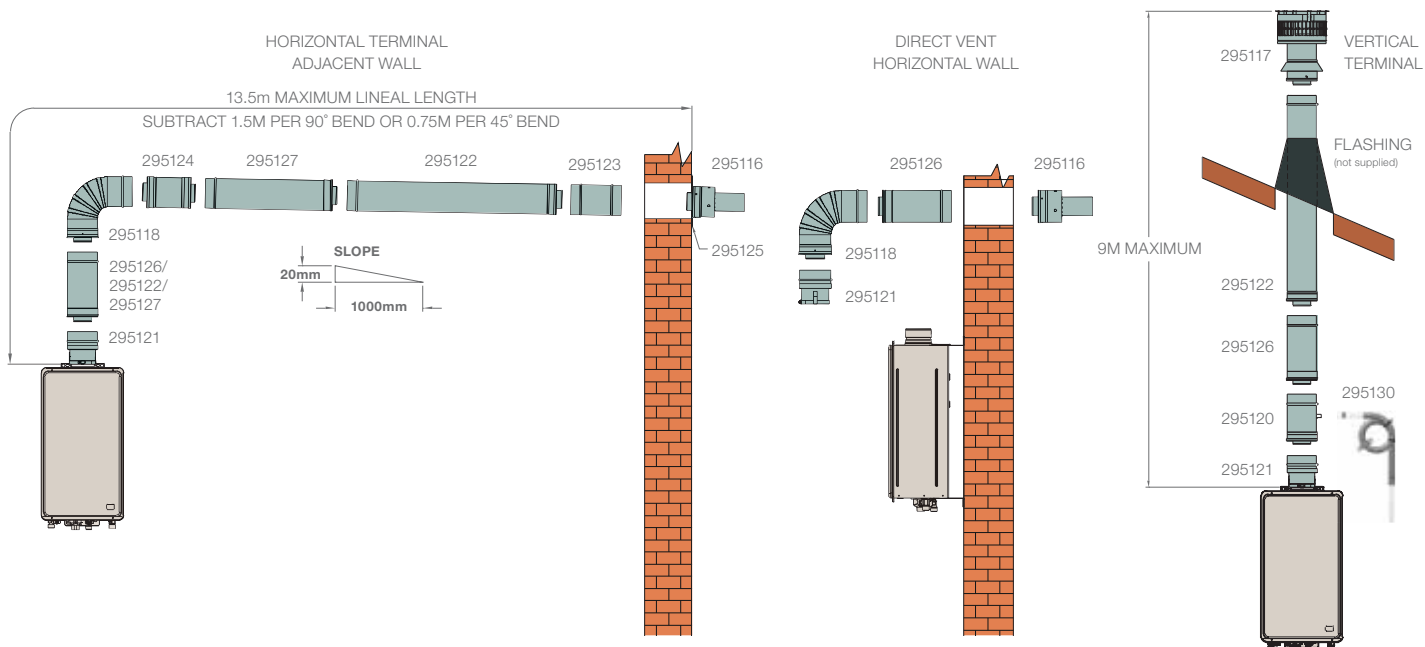

RHEEM CONTINUOUS FLOW FLUE COMPONENTS

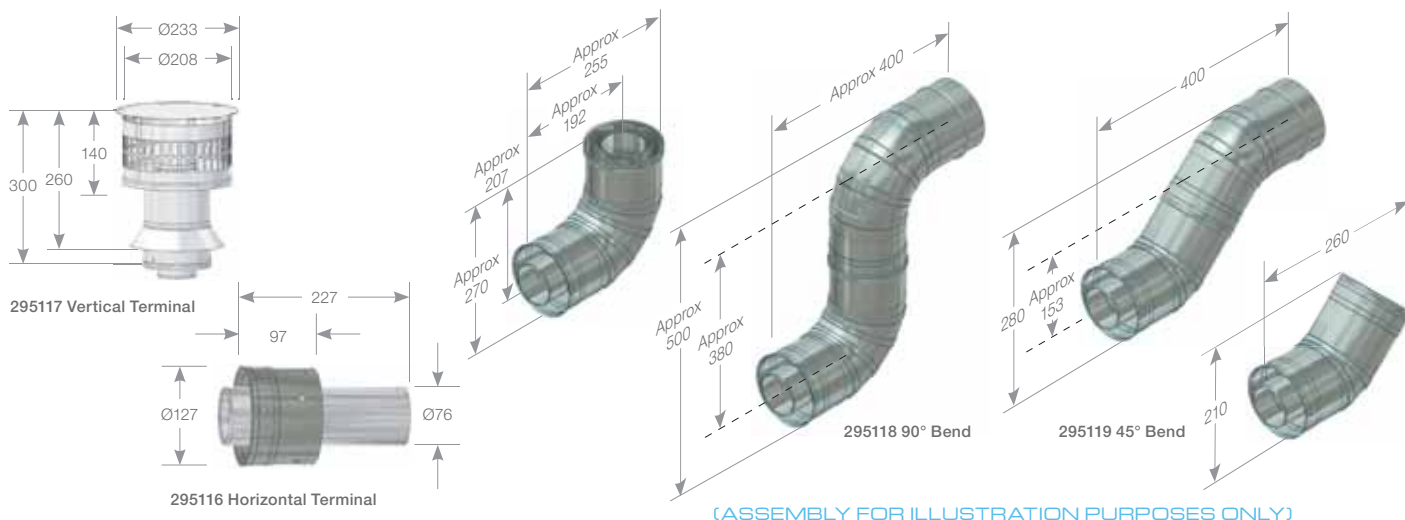

How to Size

Use the following as a guide to selecting the flue components required. The overall dimension of each flue piece is shown in the drawings. Allow approximately 35mm for insertion of each flue piece.

Determine the lineal distance and number of 45° and/or 90° bends between the top of the water heater and flue terminal. Note, the bottom edge of a vertical flue terminal must be 500mm

away from the nearest structure in accordance with AS/NZS 5601.1.

Flashing is required to be installed where a vertical flue section penetrates the roof line (not supplied).

Where a condensate drain section is installed, the hose must be connected and drained to the sewer waste or outside. A condensate trap must be installed and filled with water to prevent spillage of products of combustion.

- Flue penetrations through walls and ceilings must be sealed in accordance with local fire regulations
- Rheem CFWH are certified for installation with the terminals closer than that specified in AS/NZS 5601.1.

Adjacent water heaters may be installed with zero clearance between the water heaters.



Rheem indoor CFWH must only be installed using certified Rheem coaxial flue components. Do not use any other type of flue system. Carefully follow the installation instructions.

Use the following table as a guide to selecting Rheem Continuous Flow flue components:

P/NO	DESCRIPTION	WHERE USED
295116	Horizontal Terminal	Required where flue terminates horizontally
295117	Vertical Terminal	Required where flue terminates vertically
295118	90° Bend	Maximum of 3 per installation
295119	45° Bend	Maximum of 6 per installation (with no 90° bends)
295120	Condensate Drain	Can be located in vertical or horizontal section. Required for: – Vertically terminating flue systems – Horizontally terminating flue systems with vertical flue sections
295121	Water Heater / Flue Adapter	Required for each water heater to connect to flue system
295122	Straight Length 900mm	Long straight sections
295123	Female Female Adapter	Required to reverse flue pipe direction to allow condensate to drain away correctly from water heater in long horizontal sections of horizontally terminating flues
295124	Male Male Adapter	Required to reverse flue pipe direction to allow condensate to drain away correctly from water heater in long horizontal sections of horizontally terminating flues
295125	Trim Ring (optional)	Conceal internal and/or external hole in wall for horizontally terminating flues
295126	Straight Length 300mm	Short straight sections
295127	Adjustable Length 560 – 890mm	Allows to trim flue to exact length required
295129	Bracket	Support flue at intervals not exceeding 2m and after any bend
295130	Condensate Trap	Required with every condensate drain. Can be connected to a common waste



295130
Condensate Trap



295120 Condensate Drain



295123 FF Adapter



295129 – Bracket

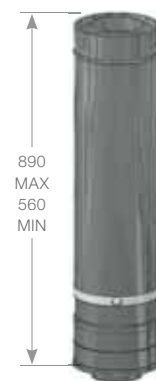

295127 – Adjustable Straight
560 – 890mm



295121 Flue Adapter/
Water heater



295124 MM Adapter



295126 Straight Length 300mm

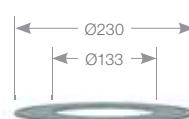

295125 Trim Ring



295122 – Straight
Length 900mm

COMMERCIAL CONTINUOUS FLOW

incl. **COMMPAK®** & **MULTIPAK®**

MULTIPAK®, COMMPAK® AND COMMPAK PLUS®

The Rheem Commpak range has been developed to provide a pre-engineered solution for commercial hot water applications. Starting with systems as small as two Commercial Continuous Flow through to systems as large as you can imagine.

All systems are pre-assembled on a sturdy aluminium frame, which can be wall or floor mounted depending on system size. A range of options are available with all systems.



Multipak®

The range starts with Multipak, which is a staged ignition system available in models comprising two to six Commercial Continuous Flow units. Typically used where large demands are required intermittently, such as in sports clubs. In 60°C temperature mode, Multipak is suitable for use in dead leg and recirculation systems. 50°C limited models are suitable for dead leg applications only.

Commpak®

Featuring mass-flow technology Commpak combines sophisticated electronics and pump technology to equalise hot and cold water pressures. A differential set point combined with the thermal mass in the system piping replicates storage. The result is mains pressure performance without the need for storage tanks reducing overall plant footprint and increasing plant efficiency. Commpak is suitable for small to medium commercial applications utilising up to six Commercial Continuous Flow units.

Commpak Plus®

Where large demands are required, Commpak Plus is the ideal choice. Starting with systems greater than six Commercial Continuous Flow units, Commpak Plus is engineered to meet customer requirements. In-line or back to back arrangements are available to meet plant room space availability. Dual pump and/or control systems are available which allows staging of the system as well as providing redundancy. Commpak Plus has BMS/BAS connectivity and systems are available in temperature delivery from 60°C to 82°C.



Multipak®



Commpak®



Commpak Plus®

Installation

Models designed to deliver temperatures in excess of 60°C can be used as an in line booster to solar pre-heat plant and can be used in conjunction with Rheem Guardian® to provide tempered or warm water.

The entire Commpak range can be specified for installation outdoors or indoors with Rheem supplied coaxial flue kits. Both indoor and outdoor Commercial Continuous Flow units are certified for installation with zero clearance between water heaters.

Multipak Models

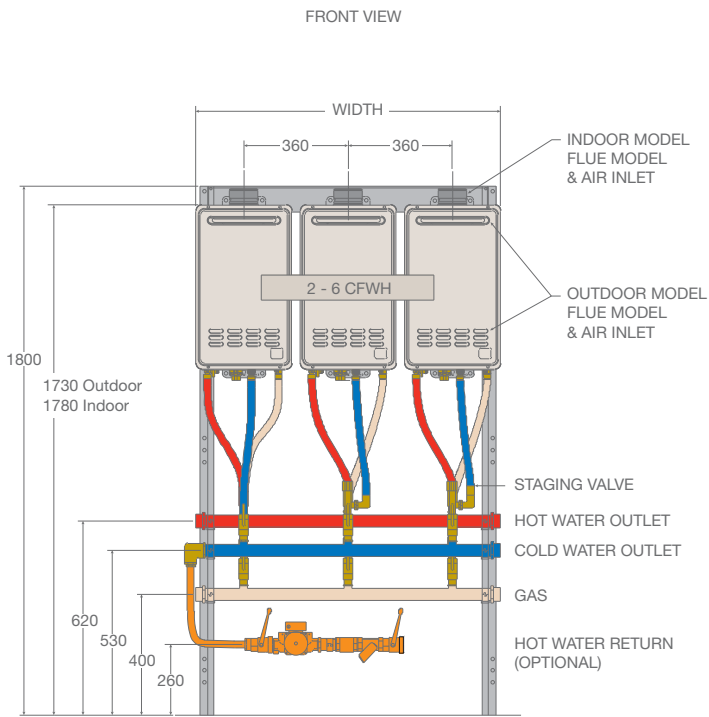

* These dimensions are applicable only for 2 and 3 water heater systems

SIDE VIEW FLOOR MOUNTING

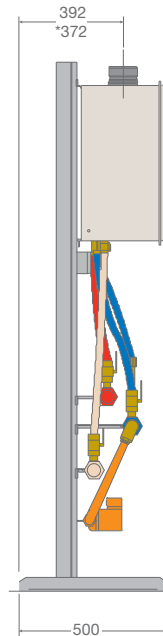

SIDE VIEW WALL MOUNTING

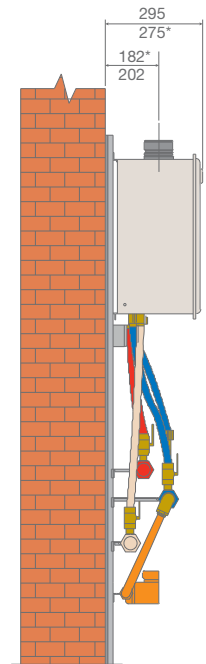

Commpak® Models

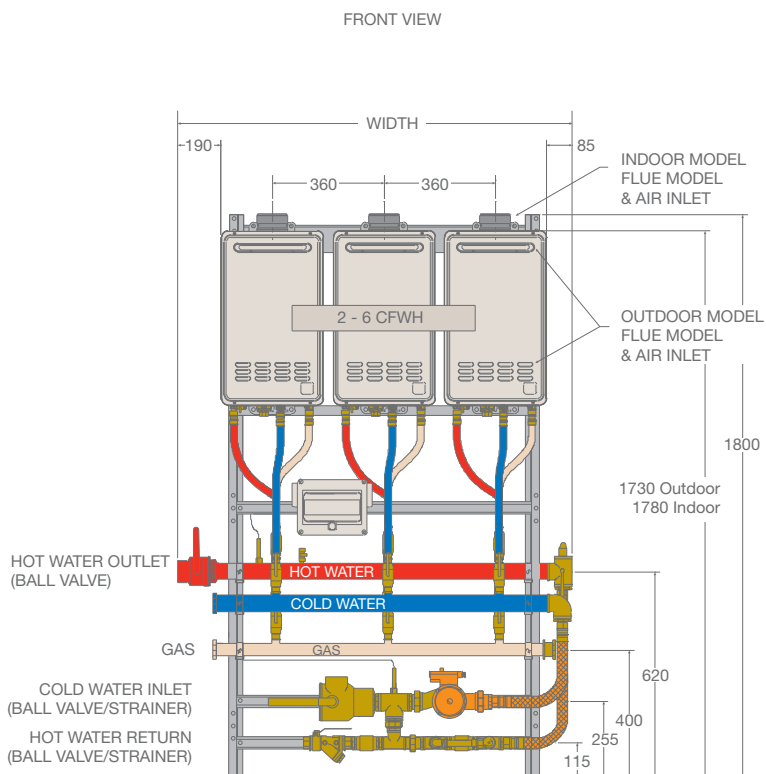

SIDE VIEW FLOOR MOUNTING

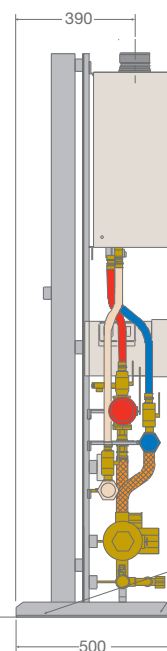

SIDE VIEW WALL MOUNTING

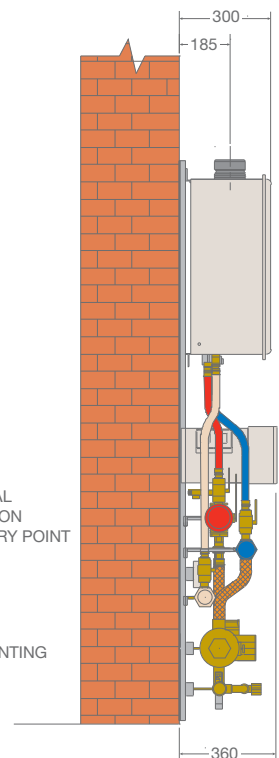

COMMERCIAL CONTINUOUS FLOW

incl. **COMMPAK®** & **MULTIPAK®**

COMMPAK AND MULTIPAK TECHNICAL DATA

MULTIPAK MODEL	INDOOR OUTDOOR	MPI 02 MPE 02	MPI 03 MPE 03	MPI 04 MPE 04	MPI 05 MPE 05	MPI 06 MPE 06
Input	MJ/h	410	615	820	1,025	1,230
Recovery Rate						
50°C rise	L/hr	1,584	2,376	3,168	3,960	4,752
25°C rise	L/hr	3,168	4,752	6,336	7,920	9,504
Maximum Flow Rate						
50°C rise	L/min	27	41	54	68	81
25°C rise	L/min	54	81	108	135	163
Minimum Flow Rate	L/min	2.0	2.0	2.0	2.0	2.0
Approx Weight	kg	95	120	185	210	235
Wall Mount		standard	standard	standard	standard	standard
Free Standing Frame (FSF)		optional	optional	optional	optional	optional
Cold Water	BSPF	RP1½/40	RP1½/40	RP1½/40	RP1½/40	RP1½/40
Hot Water	BSPF	RP1½/40	RP1½/40	RP1½/40	RP1½/40	RP1½/40
Gas	BSPM	R1½/40	R1½/40	R1½/40	R1½/40	R1½/40
Electrical Supply (240V/50Hz)	Amps	1.50	2.25	3.0	3.75	4.5
Electrical Connection		1.8m 10A Plug and Lead per CFWH				

COMMPAK MODEL	INDOOR OUTDOOR	CPI 02 CPE 02	CPI 03 CPE 03	CPI 04 CPE 04	CPI 05 CPE 05	CPI 06 CPE 06
Input	MJ/h	410	615	820	1,025	1,230
Recovery Rate						
50°C rise	L/hr	1,584	2,376	3,168	3,960	4,752
25°C rise	L/hr	3,168	4,752	6,336	7,920	9,504
Peak Flow Rate						
50°C rise	L/min	27	41	54	68	81
25°C rise	L/min	54	81	108	135	163
Approx Weight	kg	120	150	220	245	270
Wall Mount		standard	standard	–	–	–
Free Standing Frame (FSF)		optional	optional	standard	standard	standard
Cold Water	BSPF	RP2/50	RP2/50	RP2/50	RP2/50	RP2/50
Hot Water	BSPF	RP2/50	RP2/50	RP2/50	RP2/50	RP2/50
Gas	BSPM	R1½/40	R1½/40	R1½/40	R1½/40	R1½/40
Return	BSPF	RP1/25	RP1/25	RP1/25	RP1/25	RP1/25
Electrical Supply (240V/50Hz) ²³	Amps	3.62	4.62	5.62	6.62	7.92
Electrical Connection	Hard Wired	Hard Wired	Hard Wired	Hard Wired	Hard Wired	Hard Wired

COMMON SPECIFICATIONS		MPI 02, MPE 02, CPI 02, CPE 02	MPI 03, MPE 03, CPI 03, CPE 03	MPI 04, MPE 04, CPI 04, CPE 04	MPI 05, MPE 05, CPI 05, CPE 05	MPI 06, MPE 06, CPI 06, CPE 06
Dimensions						
Height (indoor / outdoor)	mm	1780/1730	1780/1730	1780/1730	1780/1730	1780/1730
Width (Multipak / Commpak)	mm	820/970	1,180/1,330	1,540/1,690	1,900/2,050	2,260/2,410
Depth (Wall Mount / Free Standing Frame)	mm	360/500	360/500	360/500	360/500	360/500
Clearance in Front (indoor / outdoor)	mm	600/800	600/800	600/800	600/800	600/800
Centre to Centre	mm	360	360	360	360	360
Frost Protection		Yes	Yes	Yes	Yes	Yes
Water Supply Pressure						
Maximum	kPa	800	800	800	800	800
Minimum	kPa	140	140	140	140	140
Gas Supply Pressure Range						
Natural	kPa	1.13 – 3.5	1.13 – 3.5	1.13 – 3.5	1.13 – 3.5	1.13 – 3.5
Propane	kPa	2.75 – 3.5	2.75 – 3.5	2.75 – 3.5	2.75 – 3.5	2.75 – 3.5

²³ Single pump add 1.62 Amps for dual pump option.