

SOLAR FRAMES

Variable Pitch Stand

Rheem solar collectors can be mounted on flat or near flat roofs using Variable Pitch Stands. The frames are galvanized inside and out and extruded aluminium collector rails and clamps offer corrosion protection. The angle of inclination can be set to 15, 20 or 25° to best suit latitude and site requirements.

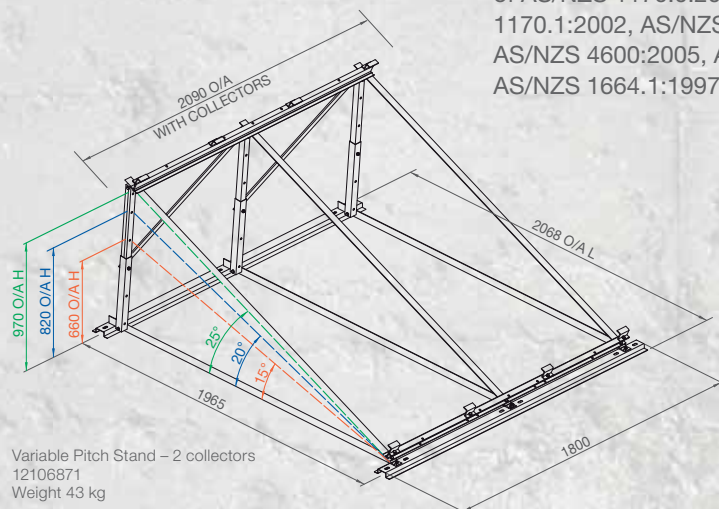

Variable Pitch Stand – 2 collectors
12106871
Weight 43 kg

With Pitch Frame

Rheem solar collectors are suitable for mounting on pitched roofs using Rheem roofing kits. Standard kits are used in most applications.

For cyclone regions C&D “With Pitch” kits are available if required. These are certified for use in terrain category 2 up to a height of 10 metres.

Rheem collector frames are designed in accordance with the relevant sections of AS/NZS 1170.0:2002, AS/NZS 1170.1:2002, AS/NZS 1170.2:2002, AS/NZS 4600:2005, AS4100-1998, AS/NZS 1664.1:1997, AS 1720.1-1997.

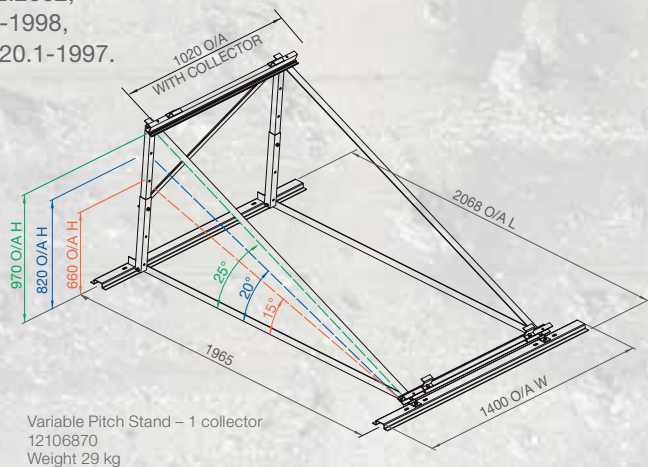

Variable Pitch Stand – 1 collector
12106870
Weight 29 kg



Design standards and requirements

It is the responsibility of the designer to determine the actual wind load acting on the solar frame and collector assembly for the installation site and satisfy themselves as to the suitability of the frame and collector assembly.

Fixing of frames to building members must be designed by a structural engineer to satisfy the design wind loads for the building.