

Rinnai

Energysaver Space Heater Co-Axial Flue System Installation Manual

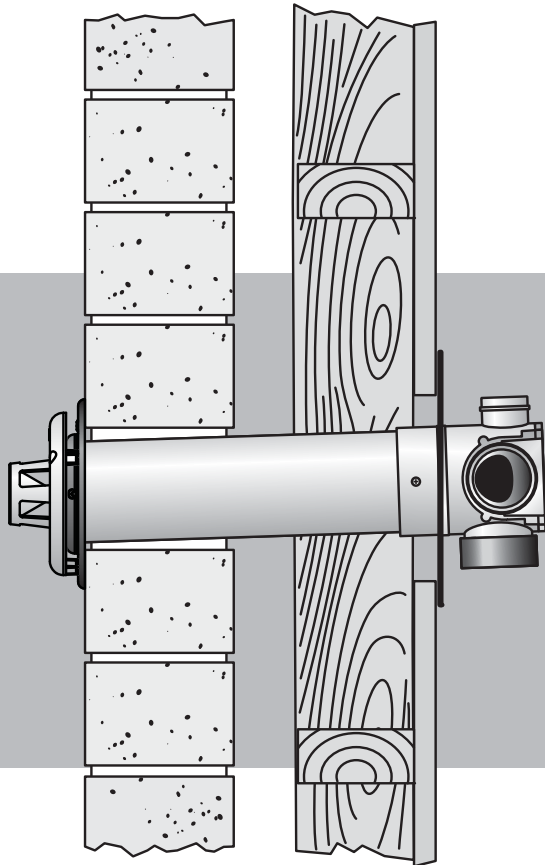

To Suit Models:

RHFE-308FTR
RHFE-309FT
RHFE-556FTR
RHFE-556FDT
RHFE-557FTR
RHFE-559FT
RHFE-1004FTR
RHFE-1004FDT

These components shall be installed in accordance with:

- Manufacturer's Installation Instructions
- Current AS/NZS 3000, AS/NZS 3500 & AS 5601
- Local Regulations and Municipal Building Codes

THESE COMPONENTS MUST BE INSTALLED, SERVICED AND REMOVED BY AN AUTHORISED PERSON!

ONLY THE FLUE SYSTEM COMPONENTS SPECIFIED IN THIS MANUAL MUST BE USED. COMPONENTS NOT SPECIFIED IN THIS MANUAL, WHETHER MANUFACTURED BY RINNAI OR OTHERWISE, ARE NOT COMPATIBLE AND "MUST NOT" BE USED!



The Australian
Gas Association
All Rinnai gas products
are A.G.A. certified.



**Quality
Endorsed
Company**
ISO 9001 Lic 4983
SAI Global
Head Office Certified

Distributed and serviced in Australia under a Quality
System certified as complying with ISO 9001 by
SAI Global

TABLE OF CONTENTS

CONVENTIONS USED IN THIS MANUAL	1
REGULATIONS, CLEARANCES & GENERAL INFORMATION	2
<i>FLUE TRANSITION CONNECTIONS</i>	3
<i>LOCATION</i>	3
<i>LUBRICATING INNER PIPE COMPONENTS</i>	3
INSTALLATION CONFIGURATIONS	4
WALL PENETRATIONS	6
FLUE KIT COMPONENTS	8
<i>CREATING A "DIRECT" FLUE INSTALLATION</i>	9
<i>CREATING A "DIRECT EXTENDED" FLUE INSTALLATION</i>	9
<i>CREATING AN "EXTERNAL WALL" FLUE INSTALLATION</i>	10
<i>CREATING A "SIDEWAYS" FLUE INSTALLATION</i>	12
<i>CREATING AN "UNDER FLOOR" FLUE INSTALLATION</i>	14
<i>CUTTING ~ ESDFK, ESPIPE900 & ESROOFCOWL</i>	17
<i>COMPONENT ASSEMBLY & CONNECTION ~ ESPIPE900</i>	17
<i>ASSEMBLING WALL TERMINAL ~ ESDFK & ESPIPE900</i>	18
<i>ASSEMBLING AN ON-WALL TERMINAL ~ ESWTKIT, ESBEND & ESPIPE900</i>	18
<i>COMPONENT ASSEMBLY & CONNECTION ~ ESBEND</i>	19
<i>COMPONENT ASSEMBLY & CONNECTION ~ ESCONDK</i>	19
<i>COMPONENT ASSEMBLY & CONNECTION ~ ESROOFCOWL</i>	19
<i>CREATING AN "IN-WALL" FLUE INSTALLATION ~ ESFKIT03 & ESKITIW</i>	20
CONNECTING HEATER EXHAUST & AIR SUPPLY	23
<i>CONNECTING HEATER EXHAUST</i>	23
<i>CONNECTING COMBUSTION AIR HOSE (AIR SUPPLY)</i>	24
CONTACT INFORMATION	26



The Rinnai Energysaver® Co-Axial flue is certified as part of the Rinnai Energysaver space heaters that have the designation 'RHFE' in the model number .

Only an authorised person must install, service and remove the Rinnai Energysaver® space heater & flue system.

Only the flue system components described in this manual must be used.

Components that are not described in this manual, whether manufactured by Rinnai or otherwise, are not compatible and must not be used. Rinnai appliance warranty conditions may be voided if non Rinnai flue components are fitted.

CONVENTIONS USED IN THIS MANUAL

The following symbols are used to highlight specific requirements during installation steps.



CLEARANCES

Where required clearances will be provided and must be observed.



FALL

Ensure that the specified 2° fall is maintained to either the terminal or condensate trap.



MEASURE

Required measurements will be provided and **MUST BE** observed for correct installation.



CUT

Cut as required to the specified measurements.



FINISH

Ensure that burrs and swarf are removed from all cut ends.



DISCARD

Denotes items that are not required for the specific installation.



OBSERVE CORRECT ORIENTATION

Where specified ensure that components are installed with the correct vertical or horizontal orientation.



LUBRICATE

Use the supplied container of silicon grease to lubricate components. **⊘ DO NOT** use other lubricants as these may damage the flue components.



SECURE

Where specified secure components with either installer provided or component supplied fixings.



DO NOT

Failure to observe **⊘ DO NOT** instructions will void the warranty of an appliance and may cause injury or death.



NOTE / IMPORTANT

Important notes or general hints and guides provided to ease the installation.



CAUTION

Caution notes and or warnings that **MUST BE** observed for safe and correct installations.

The heater and the flue system shall be installed in accordance with the following:

REGULATIONS, CLEARANCES & GENERAL INFORMATION

- The requirements of the current version of AS 5601 (Gas Installations)
Note that AS 5601-2004 is referred to in this instruction and was current at the time of printing, but may have since been superseded. It is the Installer's responsibility to ensure that requirements of the current version of AS 5601 are met.
- Manufacturers installation instructions.
Before commencing an installation, read the installation sections of the 'Customer and Installation Manual' supplied with the heater.
- Local & Municipal building codes.
- Any other relevant Statutory Regulation.
- Rinnai Energysaver space heater when correctly installed with Rinnai approved flue components are room-sealed appliances and no internal ventilation is required.
- Rinnai Energysaver space heater is fan-assisted. Therefore the fan assisted flue clearance dimensions from AS 5601 extract shown on this page must be used.
- The outer plastic section of the Co-Axial flue complies with temperature hazard requirements and can be installed with zero clearance to combustible material.
- Vertical clearances when using a roof terminal (ESROOFCOWL) are shown in Fig.1.
 If in doubt contact the Rinnai Australia Technical Advice Helpline (number on the back page).

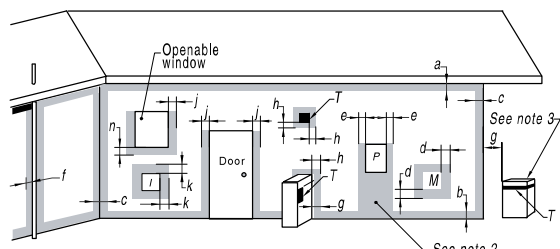

LEGEND:
 T = Flue terminal
 I = Mechanical air inlet
 M = Gas meter
 P = Electricity meter or fuse box
 Shading indicates prohibited areas for flue terminals

Ref.	Item	Minimum clearances (mm)	
		Natural draft	Fan assisted
a	Below eaves, balconies and other projections: • Appliances up to 50 MJ/h input • Appliances over 50 MJ/h input	300 500	200 300
b	From the ground, above a balcony or other surface †	300	300
c	From a return wall or external corner †	500	300
d	From a gas meter (M) (see 4.7.11 for vent terminal location of regulator)	1000	1000
e	From an electricity meter or fuse box (P)	500	500
f	From a drain pipe or soil pipe	150	75
g	Horizontally from any building structure † or obstruction facing a terminal	500	500
h	From any other flue terminal, cowl, or combustion air intake †	500	300
j	Horizontally from an openable window, door, non-mechanical air inlet, or any other opening into a building with the exception of sub-floor ventilation: • Appliances up to 150 MJ/h input • Appliances over 150 MJ/h input up to 200 MJ/h input • Appliances over 200 MJ/h input up to 250 MJ/h input † • Appliances over 250 MJ/h input † • All fan-assisted flue appliances, in the direction of discharge	500 1500 1500 1500 -	300 300 500 1500 1500
k	From a mechanical air inlet, including a spa blower	1500	1000
n	Vertically below an openable window, non-mechanical air inlet, or any other opening into a building with the exception of sub-floor ventilation: • Space heaters up to 50 MJ/h input • Other appliances up to 50 MJ/h input • Appliances over 50 MJ/h input and up to 150 MJ/h input • Appliances over 150 MJ/h input	150 500 1000 1500	150 500 1000 1500

† Unless appliance is certified for closer installation

All distances are measured to the nearest part of the terminal.

Prohibited area below electricity meter or fuse box extends to ground level.

See Clause 5.13.6.6 for restrictions on a flue terminal under a covered area.

See Appendix J, Figures J2(a) and J3(a), for clearances required from a flue terminal to an LP Gas cylinder. A flue terminal is considered to be a source of ignition.

For appliances not addressed above acceptance should be obtained from the technical regulator.

FIGURE 5.3 (in part) MINIMUM CLEARANCES REQUIRED FOR BALANCED FLUE TERMINALS, FAN-ASSISTED FLUE TERMINALS, ROOM-SEALED APPLIANCE TERMINALS OR THE TERMINALS OF OUTDOOR APPLIANCES

Horizontal Clearances (Extract AS 5601-2004 5.13.6.5 Fig. 5.3)

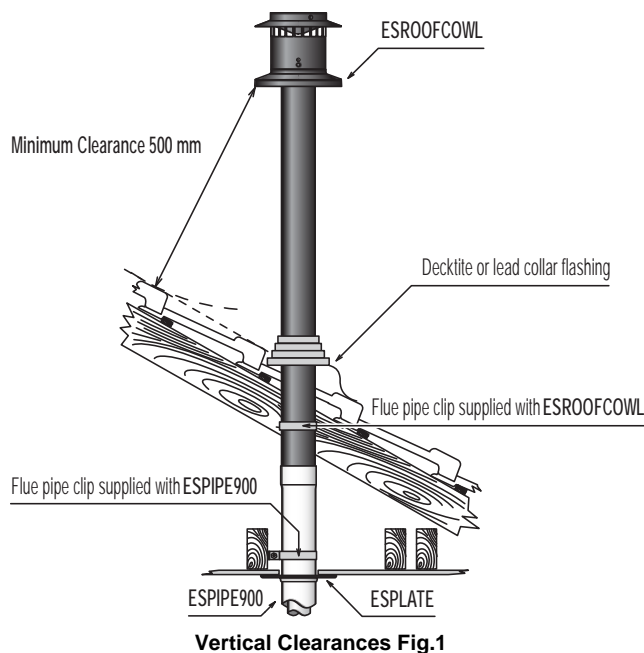

REGULATIONS, CLEARANCES & GENERAL INFORMATION

FLUE TRANSITION CONNECTIONS

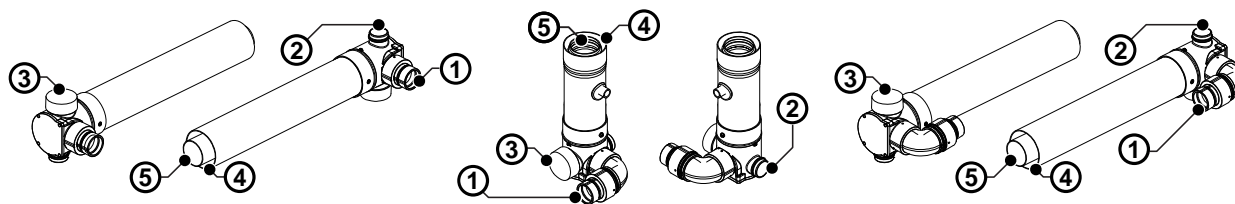

① Flue exhaust connection to heater. ② Combustion air inlet connection to heater (Right hand ~ Small connection for models 308, 309, 556, 557, 559 heaters. Left hand ~ Large connection for model 1004 heaters). ③ Rubber combustion air inlet cap (when fitted) is designed to fit both the large and small combustion air inlet and **MUST** cover the air inlet not in use. ④ Combustion air inlet. ⑤ Exhaust outlet.

LOCATION

This appliance is **NOT** suitable for inbuilt installations.

This appliance **MUST NOT** be installed where curtains or other combustible materials could come into contact with it. In some cases curtains may need restraining.

Heat emanating from the front of this appliance may over time affect the appearance of some materials used for flooring such as carpet, vinyl, cork or timber. This effect may be amplified if the air in the room contains cooking vapours or cigarette smoke. To avoid this possibility, it is recommended that a mat be placed in front of the appliance, extending at least 750mm in front of it.

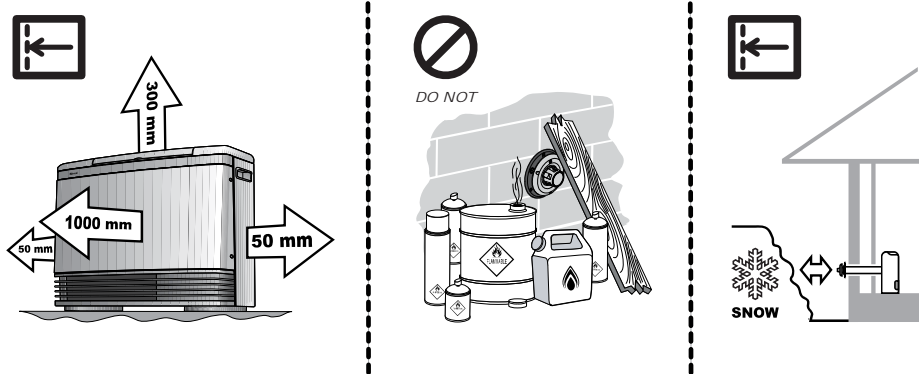

The flue terminal **MUST BE** positioned away from flammable materials.

In areas subject to heavy snowfall, keep snow clear of flue terminal at all times.

- **DO NOT** flue into natural draught flues or fireplaces.
- **DO NOT** flue into other rooms, roof spaces or into under floor spaces.
- **DO NOT** Install the heater in an unusually dusty area.

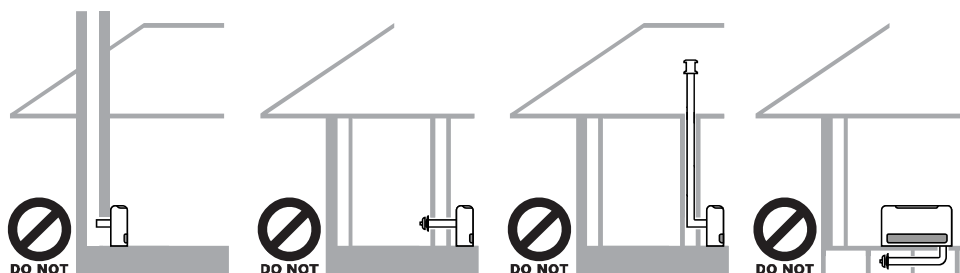

IMPORTANT For other important information regarding the location of the heater refer to the instructions supplied with the appliance.

LUBRICATING INNER PIPE COMPONENTS

The inner flue pipe joints are sealed with an "O" ring seal.

To help ensure a good seal and to ease assembly, a small tub of silicone grease is provided with the Direct Flue Kit (ESDFK) and the In-Wall Transition Kit (ESKIT03). Use this silicone grease to lubricate the "O" ring on the inner pipes prior to assembly.



Use **ONLY** the supplied silicone based "O" ring seal lubricant.

DO NOT use petroleum based lubricants such as petroleum jelly. Petroleum jelly or similar petroleum based lubricants will cause deterioration of the "O" ring seals.

INSTALLATION CONFIGURATIONS

The following configurations are currently available. For alternative configurations contact Rinnai.

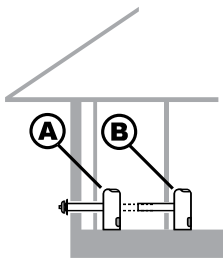
	Components			
	Option A (Direct)		Option B (Direct Extended)	
	Direct Flue Kit	ESDFK	Direct Flue Kit Co-Ax Pipe 900mm (Optional) #	ESDFK ESPIPE900

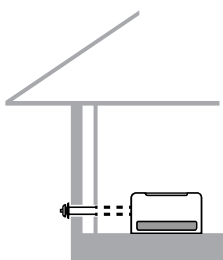
	Components		Back Cover Kit		Depth
	Direct Flue Kit	ESDFK	308	ESBSKA	200 mm
	Co-Ax Pipe 900mm #	ESPIPE900	309	ESBSKE	205 mm
Back Cover Kit	(refer page 8 for Kit contents)	556	ESBSKB	200 mm	
		557	ESBSKC	200 mm	
		559	ESBSKF	205 mm	
		1004	ESBSKD	200 mm	
<i>A Back Cover Kit is required when the flue system is installed in a sideways configuration.</i>					

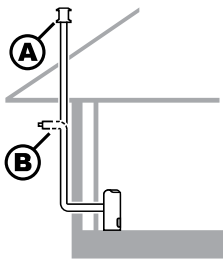
	Components			
	Option A (Vertical Termination)		Option B (On Wall Termination)	
	Direct Flue Kit	ESDFK	Direct Flue Kit	ESDFK
Co-Ax Pipe 900mm #	ESPIPE900	Co-Ax Pipe 900mm #	ESPIPE900	
Bend (2 x 45°)	ESBEND	Bend (45°) x2	ESBEND	
Condensate Trap	ESCONDK	Condensate Trap	ESCONDK	
Roof Cowl	ESROOFCOWL	Wall Terminal Kit	ESWTKIT	

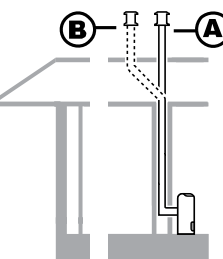
	Components			
	Option A (Direct)		Option B (Offset)	
	Vertical Adaptor Kit §	ESKIT03	Vertical Adaptor Kit §	ESKIT03
Co-Ax Pipe 900mm #	ESPIPE900	Co-Ax Pipe 900mm #	ESPIPE900	
Roof Cowl	ESROOFCOWL	Bend (45°) x2	ESBEND	
		Roof Cowl	ESROOFCOWL	

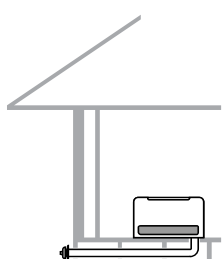
	Components		Back Cover Kit		Depth
	Direct Flue Kit	ESDFK	308	ESBSKA	200 mm
	Co-Ax Pipe 900mm #	ESPIPE900	309	ESBSKE	205 mm
Bend (2 x 45°)	ESBEND	556	ESBSKB	200 mm	
Wall Terminal Kit	ESWTKIT	557	ESBSKC	200 mm	
Back Cover Kit	(refer page 8 for Kit contents)	559	ESBSKF	205 mm	
		1004	ESBSKD	200 mm	
<i>A Back Cover Kit is required when the flue system is installed in a under floor configuration.</i>					

Order lengths as required § Includes Condensate Trap (ESCONDK)

INSTALLATION CONFIGURATIONS

• DIRECT

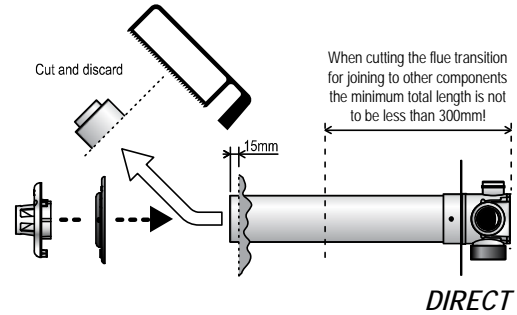
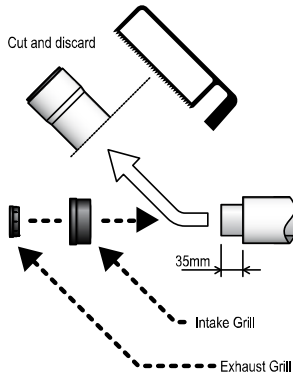

• DIRECT EXTENDED • UNDER FLOOR • SIDWAYS

• DIRECT EXTENDED • EXTERNAL WALL • IN-WALL

When cutting the flue transition for joining to other components the minimum total length is not to be less than 300mm!

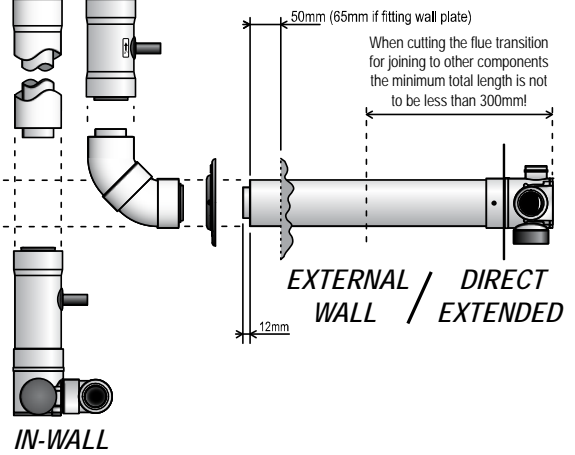
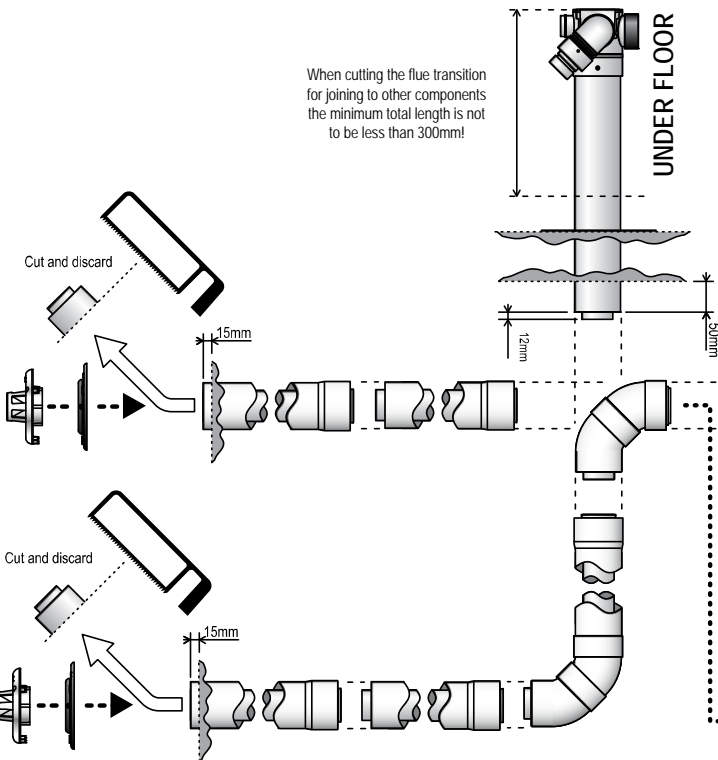

SIDWAYS

WALL PENETRATIONS

It is critical that any wall penetrations are located correctly.



Ensure there are no wall studs, noggins, wiring or other obstruction within the wall cavity where the flue is proposed to penetrate.

Ensure the location of the flue terminal can comply with the requirements of AS 5601. Figure 5.3 from AS 5601-2004 and additional information is shown on page 2.

Especially relevant is the requirement to have a minimum of 300mm clearance between the flue terminal and the finished ground level. It is not permissible to excavate a hole to obtain the required 300mm clearance, unless there is sufficient drainage provision.

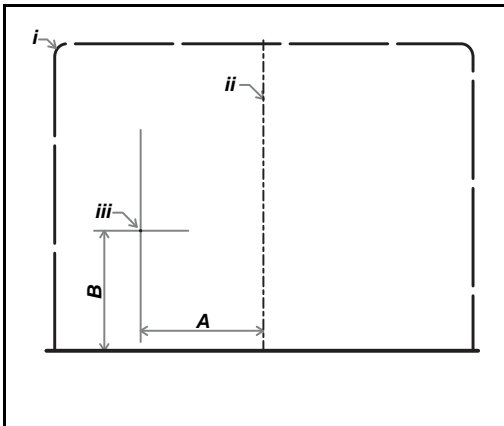

1. Select the desired location *i* for the Energysaver Heater.
2. Find the vertical centre line of the appliance *ii* and mark this location on the wall.
3. Using Measurements **A** & **B** from **Table 1**, mark off the arc centre *iii* on the wall.



The arc centre *iii* corresponds to the pivot point centre of the telescopic flue elbow on the heater.

The RHFE-308 and RHFE-309 have a fixed length non-telescopic flue elbow. Hence accurate marking of the penetration arc and associated area are therefore especially critical.

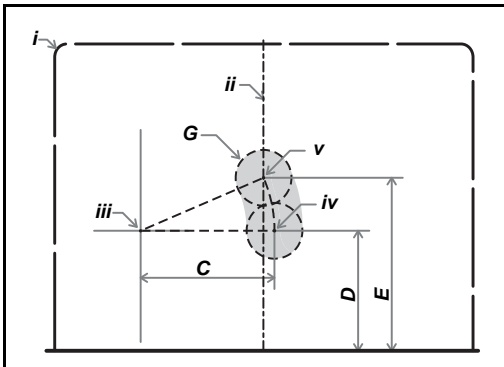

4. From the arc axis *iii* use the measurements **C**, **D** & **E** from **Table 1**, to draw an arc on the wall.

The lower end point of the arc *iv* will be the lower limit of the minimum horizontal and vertical centre of penetration **G**.

The upper end point of the arc *v* will be the upper limit of the minimum horizontal and vertical centre of penetration **G**.

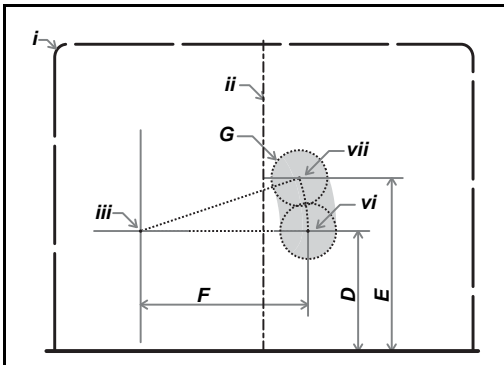

5. From the arc axis *iii* use the measurements **F**, **D** & **E** from **Table 1**, to draw an arc on the wall.

The lower end point of the arc *vi* will be the lower limit of the maximum horizontal and vertical centre of penetration **G**.

The upper end point of the arc *vii* will be the upper limit of the maximum horizontal and vertical centre of penetration **G**.



Due to the fixed length non-telescopic flue elbow of the RHFE-308 and RHFE-309 model heaters measurements **C** & **F** are the same for these model only.

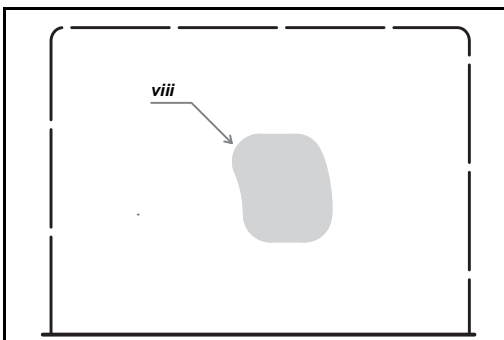

6. The penetration may be made anywhere within the confines of the shaded minimum and maximum areas *viii* defined by the two arcs.

WALL PENETRATIONS

Below are diagrams and associated dimension tables for wall penetrations for each Energysaver heater model.

RHFE 308

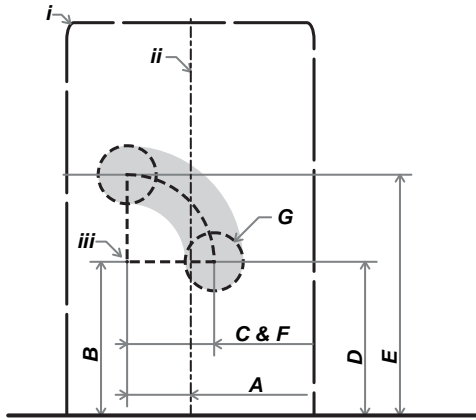

RHFE 309

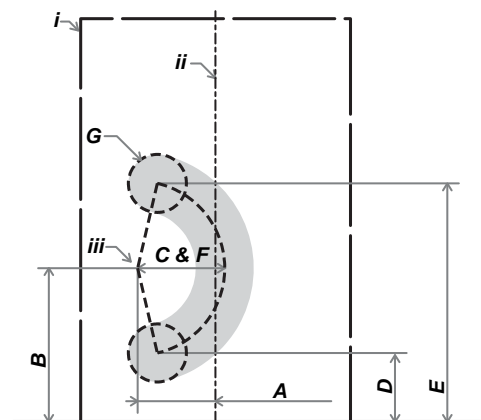

RHFE 556

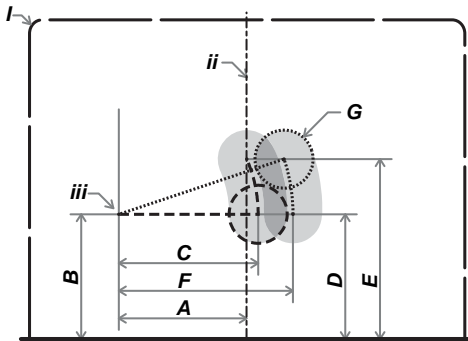

RHFE 559

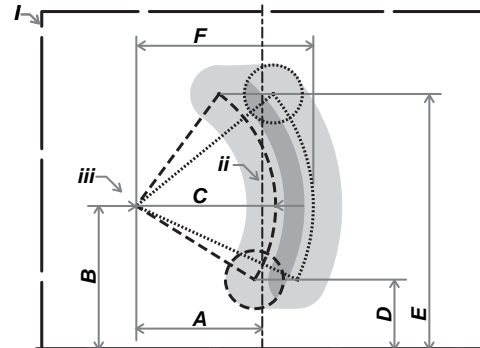

RHFE 557

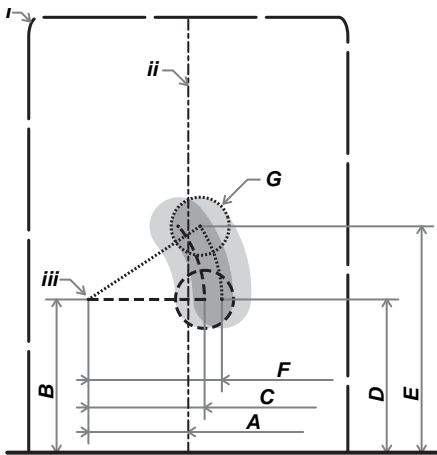

RHFE 1004

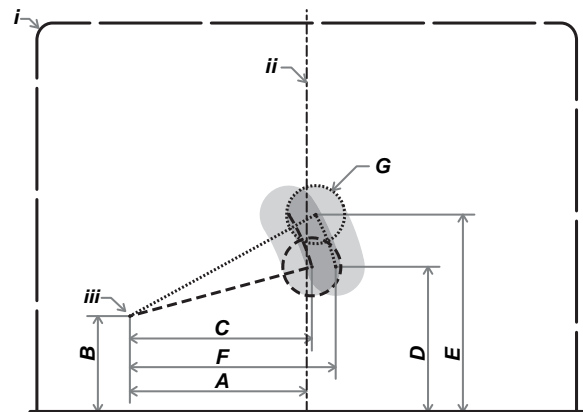

All dimension are in millimetres

	RHFE 308	RHFE 309	RHFE 556	RHFE 557	RHFE 559	RHFE 1004
<i>i</i> Width of appliance	426	465	750	550	760	930
<i>ii</i> Centre-Line of appliance	213	233	375	275	380	465
<i>iii</i> Arc axis (Axis point of the flue elbow)	—	—	—	—	—	—
A Horizontal distance from Centre-Line to arc centre	110	134	220	172	217	305
B Vertical distance from base to arc centre	265	265	215	264	247	165
C Minimum horizontal limit of arc	150	150	240	200	240	325
D Minimum vertical limit of arc	265	120	215	264	120	250
E Maximum vertical limit of arc	415	410	310	390	440	340
F Maximum horizontal limit of arc	150	150	300	230	305	365
G Penetration diameter	100	100	100	100	100	100

Table 1.

FLUE KIT COMPONENTS

ESDFK (Direct Flue Kit)

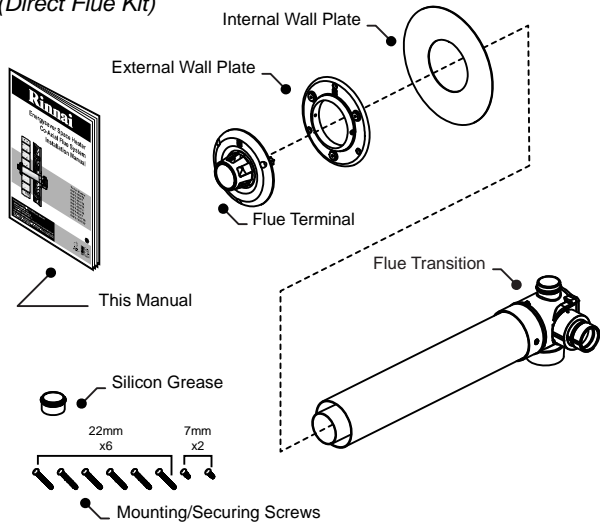

ESFKITIW (In-Wall Transition, Flue & Cowl Kit)

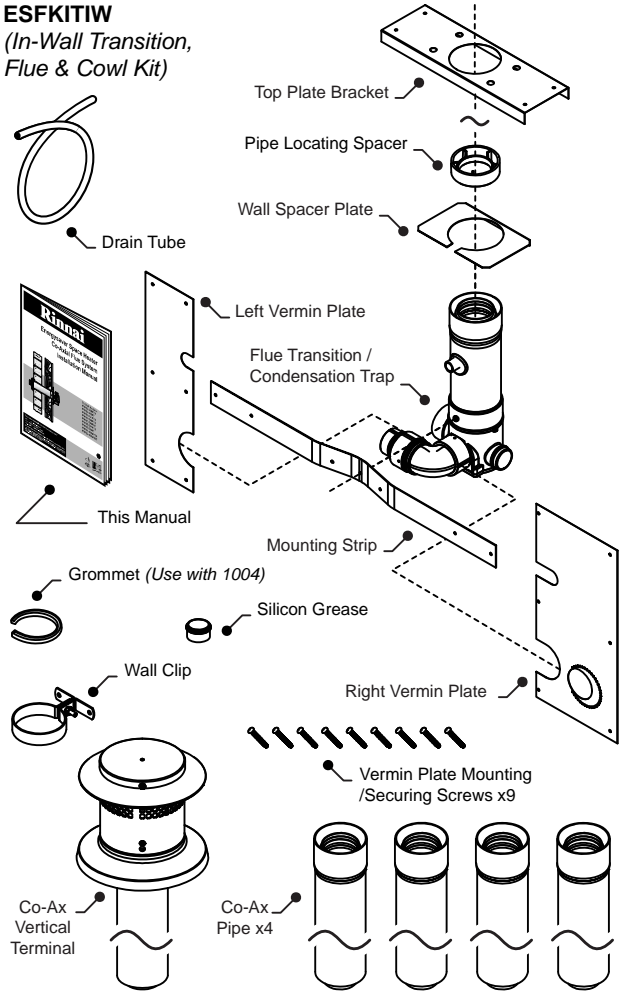

ESKIT03 (In-Wall Transition Kit)

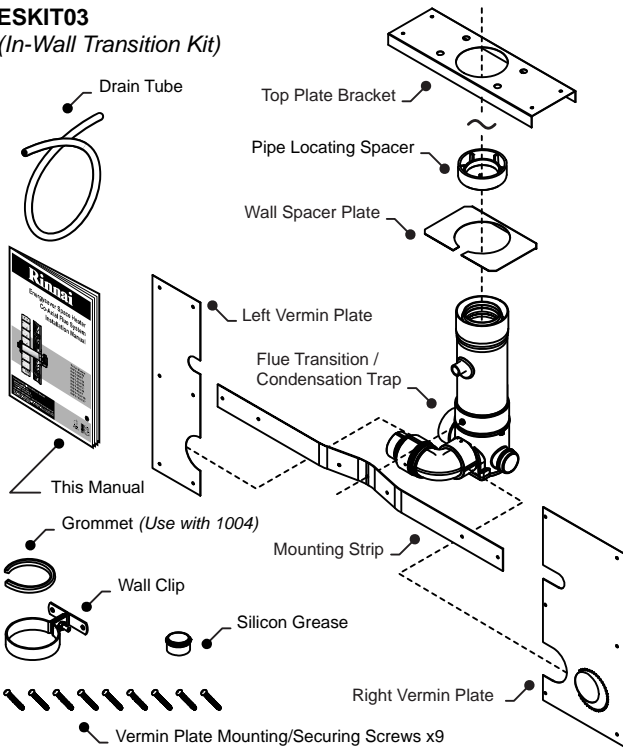

ESPIPE900

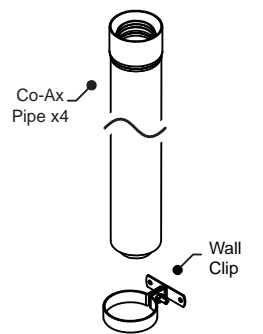

ESROOFCOWL

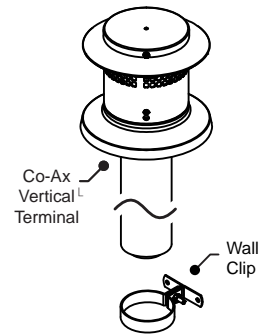

ESBEND

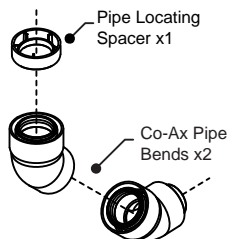

ESCONDK (Condensate Trap Kit)

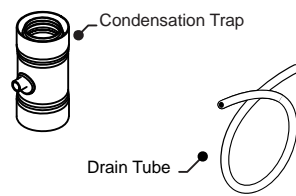

ESPLATE

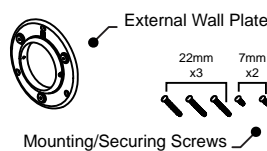

ESWFG

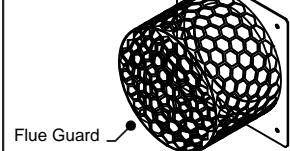

ESWTERM

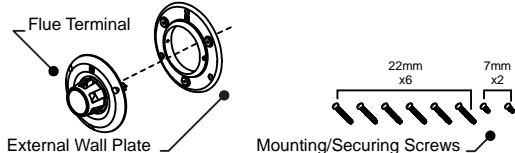

ESWTKIT (On-Wall Terminal Kit)

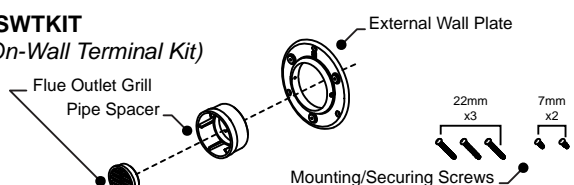

FLUE COMPONENT ASSEMBLY

CREATING A "DIRECT" FLUE INSTALLATION

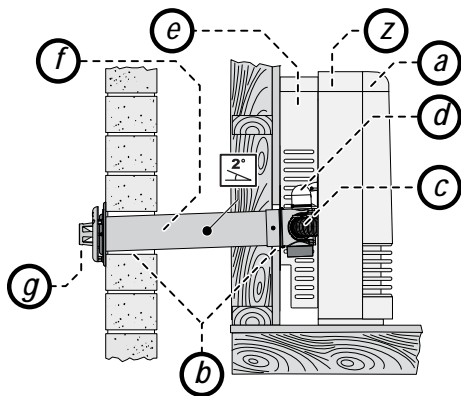

Activities for creating a Direct flue installation:

- Locate Heater.
- Create Wall Penetration.
- Connect Heater Exhaust.
- Connect Combustion Air Hose.
- Installation and fastening of Back Cover Kit.
- Cut Components (as required).
- Assemble Wall Terminal.
- Finalise Installation & Commissioning of Heater.

The Direct flue kit (ESDFK) is suitable for walls up to 385mm thick. ESDFK can be cut to length to suit wall thicknesses less than 385mm thick. For wall thicknesses greater than 385mm Co-Ax Pipe(s) (ESPIPE900) can be fastened onto ESDFK to extend the flue length. Refer to the section "CREATING A "DIRECT EXTENDED" FLUE INSTALLATION" on page 9 for details.

Steps for creating a DIRECT flue installation are as follows:

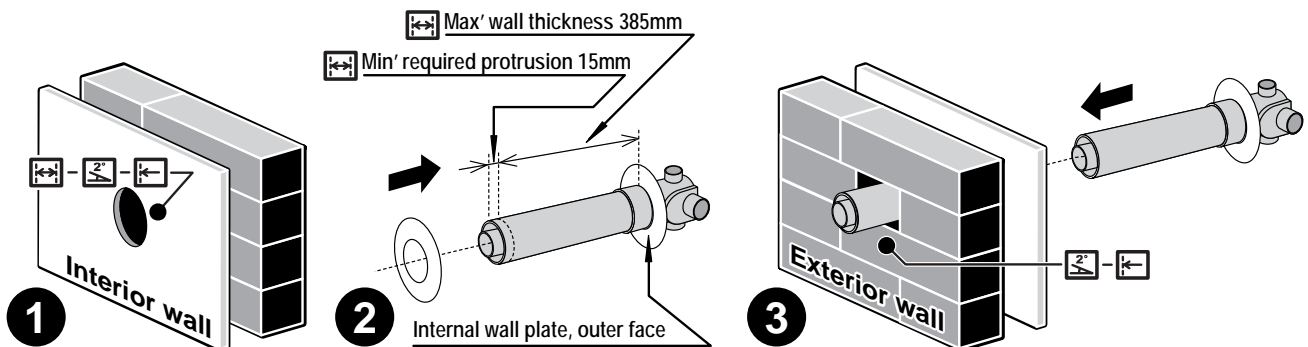

- Create the wall penetration(s) in accordance with the section "WALL PENETRATIONS" refer to page 6

The minimum diameter required for wall the penetration for a DIRECT flue installation is 80mm to non combustible surfaces such as brick and 100mm to combustible surfaces such as plaster.

Allow for a continuous 2° fall from the heater connection point to the wall terminal.

- Slide the internal wall plate over the terminal end of the ESDFK pipe until it is nested on the raised ring of the flue transition.
- Pass the ESDFK through the internal wall penetration until the internal wall plate is flush with the wall.
- Create the wall terminal in accordance with "ASSEMBLING WALL TERMINAL ~ ESDFK & ESPIPE900" refer to page 18.
- Make the heater exhaust and combustion air hose connections in accordance with the section "CONNECTING HEATER EXHAUST & AIR SUPPLY" refer to page 23.



Air hose and heater exhaust connections at the Energysaver heater MUST be made and checked in accordance with these instructions. Improper connections may result in dangerous situations, for example, the dispersion of combustion products in the space being heated.

- Install the correct back cover kit and fasten the heater and back cover kit to the internal wall surface.
- Commission the heater in accordance with the manufacturer instructions supplied with the heater.

CREATING A "DIRECT EXTENDED" FLUE INSTALLATION

The Direct flue kit (ESDFK) is suitable for walls up to 385mm thick. For wall thicknesses greater than 385 mm Co-Axial Pipe(s) (ESPIPE900) can be fastened onto ESDFK to extend the flue length.

FLUE COMPONENT ASSEMBLY

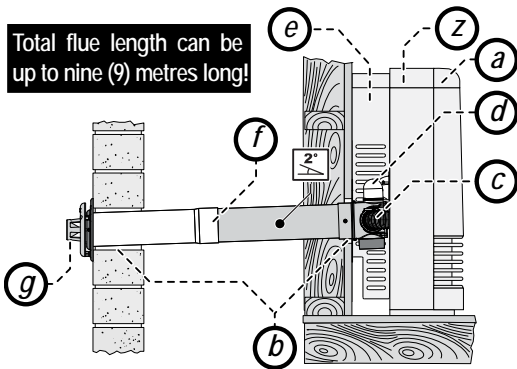

Activities for creating a Direct Extended flue installation:

- Locate of Heater.
- Create Wall Penetration.
- Connect Heater Exhaust.
- Connect Combustion Air Hose.
- Installation and fastening of Back Cover Kit.
- Cut, Fit & Secure Components (as required).
- Assemble Wall Terminal.
- Finalise Installation & Commissioning of Heater.

Steps for creating a Direct Extended flue installation are as follows:

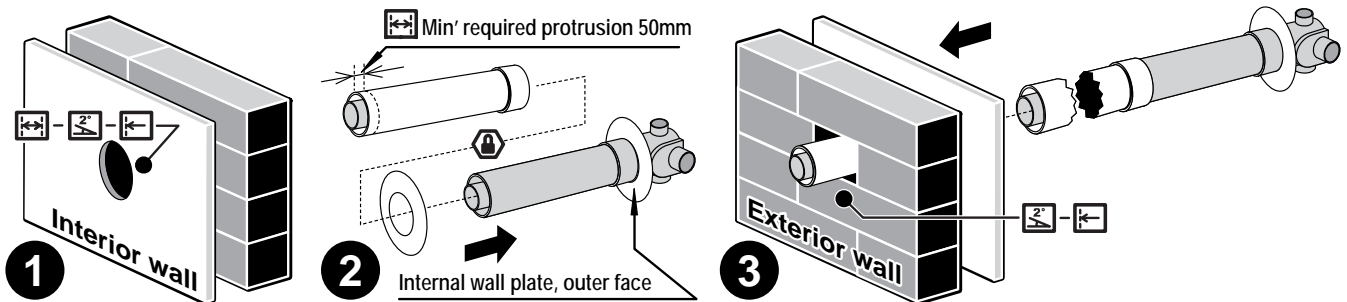

- Create the wall penetration(s) in accordance with the section "WALL PENETRATIONS" on page 6.

The minimum diameter required for wall the penetration for a DIRECT flue installation is 80mm to noncombustible surfaces such as brick and 100mm to combustible surfaces such as plaster.

Allow for a continuous 2° fall from the heater connection point to the wall terminal.

- Join ESPIPE900 to ESDFK. Fit additional lengths of ESPIPE900 as required.



The joints between ESDFK and ESPIPE900 and any additional ESPIPE900 lengths **MUST BE secured by a pop rivet or screw through the outer Co-Ax pipes to prevent accidental or erroneous dislodgement. ESDFK and ESPIPE900 DO NOT require cutting to be joined.**



Cutting of components is not required for the purposes of joining and ESPIPE900 to ESDFK or other ESPIPE900.

Slide the internal wall plate over the terminal end of the assembled flue pipe until it is nested on the raised ring of the flue transition.

- Pass the flue assembly through the internal wall penetration until the internal wall plate is flush with the wall.
- Create the wall terminal in accordance with "ASSEMBLING WALL TERMINAL ~ ESDFK & ESPIPE900" refer to page 18.
- Make the heater exhaust and combustion air hose connections in accordance with the section "CONNECTING HEATER EXHAUST & AIR SUPPLY" refer to page 23.



Air hose and heater exhaust connections at the Energysaver heater **MUST be made and checked in accordance with these instructions. Improper connections may result in dangerous situations, for example, the dispersion of combustion products in the space being heated.**

- Install the back cover kit and fasten the Energysaver heater and back cover kit to the internal wall surface.
- Commission the heater in accordance with the manufacturer instructions supplied with the heater.

CREATING AN "EXTERNAL WALL" FLUE INSTALLATION

The creation of the horizontal section of flue installation is the same as creating a DIRECT or DIRECT EXTENDED flue installations with the following exceptions:

FLUE COMPONENT ASSEMBLY

Total flue length can be up to nine (9) metres long and can contain a maximum of three (3) ESBEND (3 x 90°)!

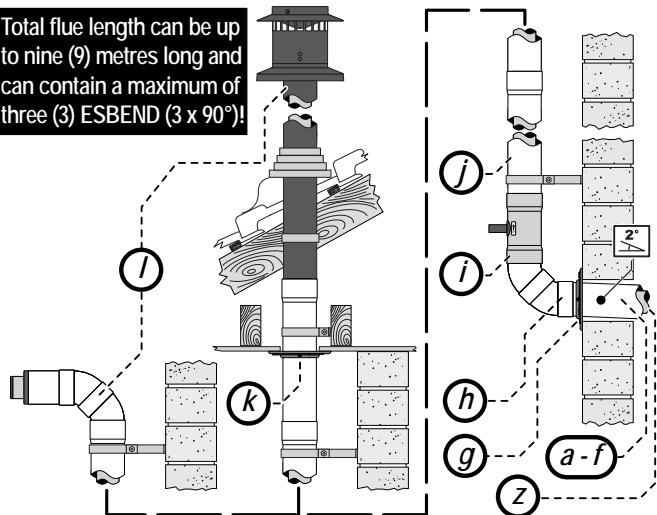

- Activities for creating an External Wall installation:
- a. - f. Refer to Direct & Direct Extended (as required).
 - g. Assemble Wall Plate.
 - h. Assemble & Fit Bend.
 - i. Fit Condensate Drain.
 - j. Cut, Fit & Secure Components. Seal Joints (as required). 
 - k. Create Vertical Penetrations (as required).
 - l. Fit & Fasten Roof Cowl or On-Wall Terminal.
 - z. Finalise Installation & Commissioning of Heater.

 The direction of horizontal fall of the flue pipe is reversed. For Wall External flue installations, a 2° fall is required from the wall penetration towards the heater. This will ensure the small amount of condensation in the short section between the heater and condensation trap will 'burn' off rapidly during normal operation.

An ESBEND rather than a mushroom flue terminal is fitted at the end of the horizontal flue run.



Sections of flue installation located outside require the following precautions:



 **ONLY** use PVC cement between joints of the 'outer' PVC flue pipes to secure and seal these joints against ingress of dust and water.

 **ONLY** use non acidic silicone sealant between the joints of 'outer' PVC flue pipes and any mating aluminium components (such as the condensate trap) to secure and seal these joints against ingress of dust and water. Silicone containing acetic acid (vinegar) or other acids as the curing agent may cause corrosion of aluminium components and must not be used.

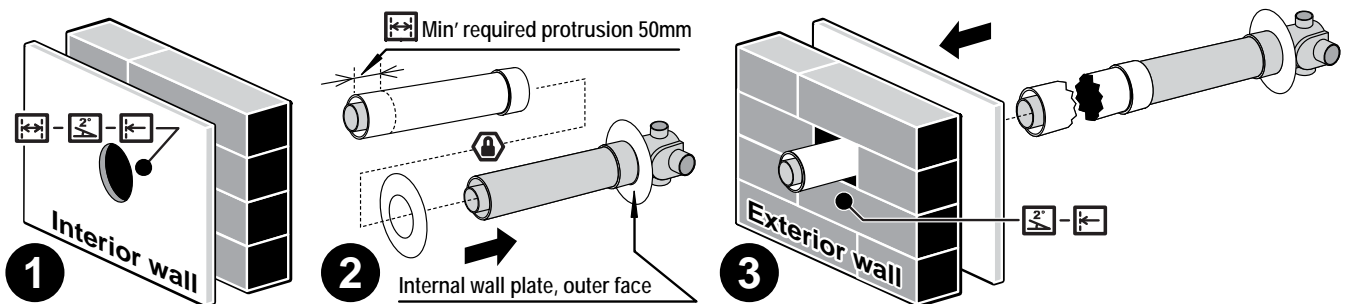
Steps for creating a External-Wall flue installation are as follows:



1. Create the wall penetration(s) in accordance with the section "WALL PENETRATIONS" refer to page 6.

  The minimum diameter required for wall the penetration for a DIRECT flue installation is 80mm noncombustible surfaces such as brick and 100mm to combustible surfaces such as plaster.

 Allow for a continuous 2° fall towards the heater connection point from the external wall penetration.

2. Prepare the 'horizontal' section by following step 2 of "CREATING A "DIRECT" FLUE INSTALLATION" refer to page 9 or step 2 of "CREATING A "DIRECT EXTENDED" FLUE INSTALLATION" refer to page 9 depending on wall thickness (*note that a direct extended flue installation example is illustrated above*).

Slide the internal wall plate over the terminal end of the assembled flue pipe until it is nested on the raised ring of the flue transition.

3. Pass the flue assembly through the internal wall penetration until the internal wall plate is flush with the wall.

FLUE COMPONENT ASSEMBLY

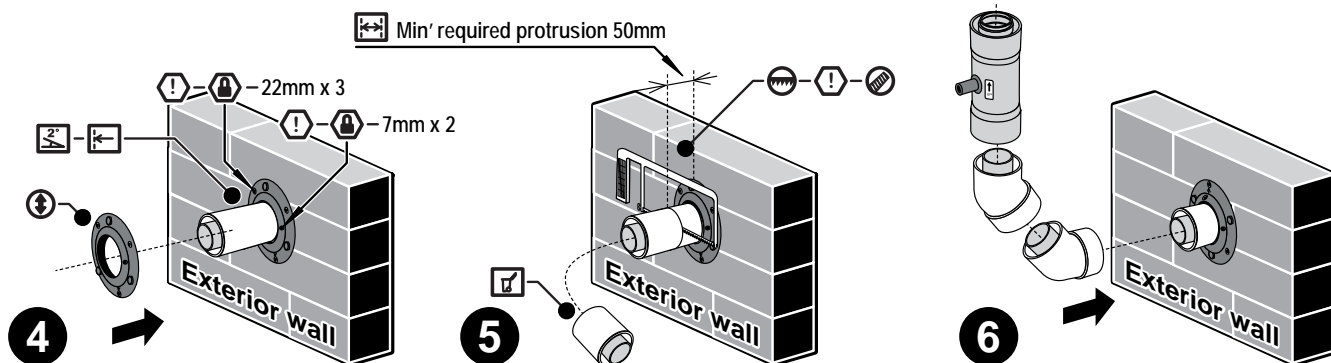

4. Slide the external wall plate over the outer pipe protruding through the exterior wall. Align the arrow symbol to point downwards which will result in a 2° fall of the horizontal section of flue pipe towards the appliance as required.
 - Once the external wall plate is in the correct position secure it to the wall using the three 22mm screws into the holes provided. The wall plate is then secured to the outer pipe of the flue protrusion using the two horizontal holes and the two 7mm screws provided.
5. Cut the flue pipe end protruding through the exterior wall in accordance with “CUTTING ~ ESDFK, ESPIPE900 & ESROOFCOWL” refer to page 17.

CAUTION The joints between ESDFK and ESPIPE900 and any additional ESPIPE900 lengths **MUST BE secured by a pop rivet or screw through the outer Co-Ax pipes to prevent accidental or erroneous dislodgement. ESDFK and ESPIPE900 DO NOT require cutting to be joined.**

6. Now prepare the vertical section of the flue system by assembling, connecting and securing ESBEND, ESCONDK and subsequent ESPIPE900 lengths as required in accordance with the relevant sections under “COMPONENT ASSEMBLY & CONNECTION ~ ESBEND” refer to page 18, “COMPONENT ASSEMBLY & CONNECTION ~ ESCONDK” refer to page 18 and “COMPONENT ASSEMBLY & CONNECTION ~ ESPIPE900” refer to page 17.

CAUTION **ONLY use PVC cement between joints of the 'outer' PVC flue pipes to secure and seal these joints against ingress of dust and water.**

ONLY use non acidic silicone sealant between the joints of 'outer' PVC flue pipes and any mating aluminium components (such as the condensate trap) to secure and seal these joints against ingress of dust and water. Silicone containing acetic acid (vinegar) or other acids as the curing agent may cause corrosion of aluminium components and must not be used.

Secure the vertical flue sections to the wall using the clips provided to prevent accidental dislodgement.

7. If a vertical roof terminal is used cut in accordance with “CUTTING ~ ESDFK, ESPIPE900 & ESROOFCOWL” refer to page 17 and assemble and connect in accordance with “COMPONENT ASSEMBLY & CONNECTION ~ ESROOFCOWL” refer to page 19.

If a horizontal terminal is used cut in accordance with “CUTTING ~ ESDFK, ESPIPE900 & ESROOFCOWL” refer to page 17 and assemble and connect in accordance with “ASSEMBLING AN ON-WALL TERMINAL ~ ESWTKIT, ESBEND & ESPIPE900” refer to page 18.

8. Make the heater exhaust and combustion air hose connections in accordance with the section “CONNECTING HEATER EXHAUST & AIR SUPPLY” refer to page 23.

CAUTION **Air hose and heater exhaust connections at the Energysaver heater MUST be made and checked in accordance with these instructions. Improper connections may result in dangerous situations, for example, the dispersion of combustion products in the space being heated.**

9. Install the back cover kits and fasten the heater and back cover kit to the internal wall surface.
10. Commission the heater in accordance with the manufacturer instructions supplied with the heater.

CREATING A “SIDEWAYS” FLUE INSTALLATION

FLUE COMPONENT ASSEMBLY

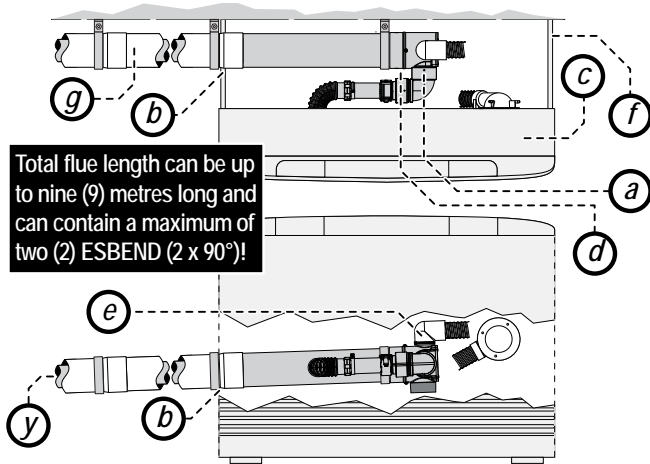

Activities for creating a Sideways flue installation:

- a. Modify ESDFK for Sideways Installation.
 - b. Create Penetration in Side Panel. *
 - c. Locate Heater.
 - d. Connect Heater Exhaust.
 - e. Connect Combustion Air Hose.
 - f. Installation and fastening of Back Cover Kit (ESBSK).
 - g. Cut, Fit & Secure Components (as required).
 - y. Refer to steps f & g of Direct & Direct Extended (as required).
 - z. Finalise Installation & Commissioning of Heater.
- * Create penetration only in side panel associated with the direction of the horizontal flue run.

The Sideways flue installation can run along the left or right hand side of the internal wall behind the heater.

Most components in a sideways flue installation are located indoors and may be in an accessible position after installation. To prevent accidental or erroneous dislodgement, the joints between ESDFK and ESPIPE900 components MUST BE secured by pop rivet or screw through the outer Co-Ax pipes and flue pipes are to be clipped to the wall using the stand off clips supplied or other suitable method.

Steps for creating a Sideways flue installation are as follows:

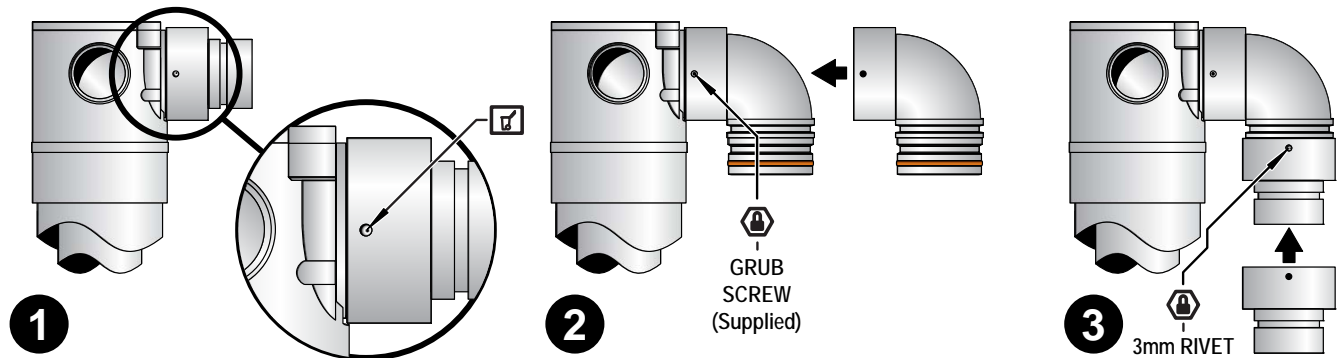

1. Using a drill, remove the pop rivet used to fasten the straight flue pipe connection pipe to the flue transition of ESDFK and remove but do not discard the straight flue pipe connection.
2. Fit the elbowed flue pipe connection supplied with the Back Cover kit to the flue transition pushing it fully home and then fasten in place with the grub screw (supplied) using an Allen key. The grub screw terminates in a groove in the flue transition. When fastened this prevents accidental dislodgement of the pipe connections.
3. Refit the straight flue pipe connection to the end of the elbow until it is fully home and then fasten in place with a 3mm rivet.

Ensure the straight pipe and elbow are securely fastened to the flue transition by the grub screw and rivets. Test soundness of the connections by attempting to 'pull apart' the assembled components. Improper assembly or fastening can result in products of combustion dispersing into the room being heated which may result in a dangerous condition.

4. Temporarily position the heater in the desired position.
5. Attach ESDFK to the flue outlet pipe from the rear of the heater. Align the flue in an almost horizontal manner in the desired direction of discharge (either left or right) with a 2° fall towards the flue terminal.

Ensure the flue components are positioned to have a minimum 25mm clearance from any sensor wires at the rear of the heater.

FLUE COMPONENT ASSEMBLY

6. Attach the appropriate side spacer panel from the back cover kit (ESBSK A, B, C, D, E or F) to the rear of the heater in accordance with the assembly Instructions supplied with the back cover kit.
7. Mark the location of the flue penetration through the side spacer panel.
8. Remove the side cover panel and cut or knock out an 85mm Ø hole for the flue pipe to pass through. Ensure the hole edges are smooth.
9. Fit the protective plastic edge supplied with the back cover kit around the circumference of the hole in the side spacer panel.
10. Fit a length of ESPIPE900 to ESDFK in accordance with "COMPONENT ASSEMBLY & CONNECTION ~ ESPIPE900" refer to page 17.



The joint between ESDFK and ESPIPE900 MUST BE secured by a pop rivet or screw through the outer Co-Ax pipes and flue pipes are to be clipped to the wall using the stand off clips supplied or other suitable method. ESDFK and ESPIPE900 DO NOT require cutting to be joined.

11. Re-attach the side spacer panel to the heater with the flue pipe passing through it.
12. Locate the heater in the desired position relative to the wall. **DO NOT** secure the heater at this stage.
13. Fit additional lengths of ESPIPE900 as required.



The joints between ESPIPE900 lengths MUST BE secured by a pop rivet or screw through the outer Co-Ax pipes and flue pipes are to be clipped to the wall using the stand off clips supplied or other suitable method. ESDFK and ESPIPE900 DO NOT require cutting to be joined.

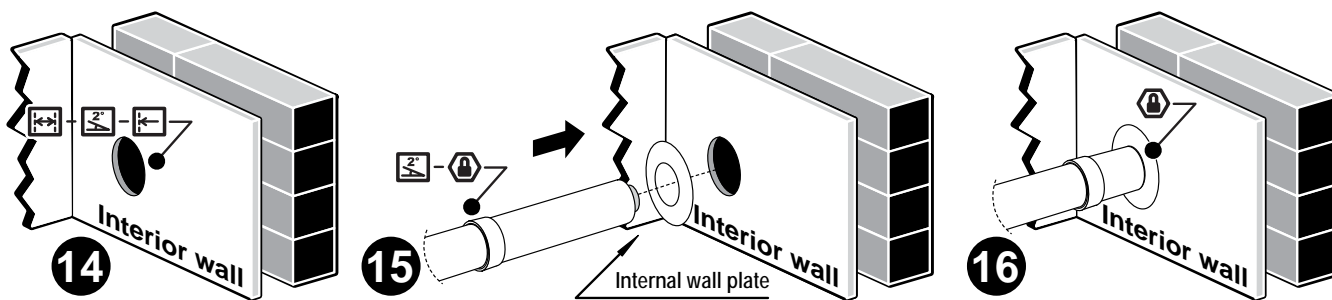

14. Create the wall penetration(s) in accordance with the section "WALL PENETRATIONS" refer to page 6.
 - The minimum diameter required for wall the penetration for ESPIPE900 is 80mm.
 - Allow for a continuous 2° fall from the heater connection point from to the wall penetration.
15. Slide the internal wall plate supplied with ESDFK over the length of ESPIPE900 penetrating the wall at the internal wall end. Then pass the assembly through the internal wall penetration.
16. Fasten the internal wall plate to the internal wall.
17. Create the wall terminal in accordance with "ASSEMBLING WALL TERMINAL ~ ESDFK & ESPIPE900" refer to page 18. Make the heater exhaust and combustion air hose connections in accordance with the section "CONNECTING HEATER EXHAUST & AIR SUPPLY" refer to page 23.



Air hose and heater exhaust connections at the heater MUST be made and checked in accordance with these instructions. Improper connections may result in dangerous situations, for example, the dispersion of combustion products in the space being heated.

18. Install the remaining parts of the back cover kit and fasten the heater and back cover kit to the internal wall surface.
19. Commission the heater in accordance with the manufacturer instructions supplied with the heater.

CREATING AN "UNDER FLOOR" FLUE INSTALLATION

The Down & Out flue option allows for a direct flue kit (ESDFK) to face downwards and the flue to be run vertically through a hole in the floor, and then horizontally to a suitable location outside.

FLUE COMPONENT ASSEMBLY

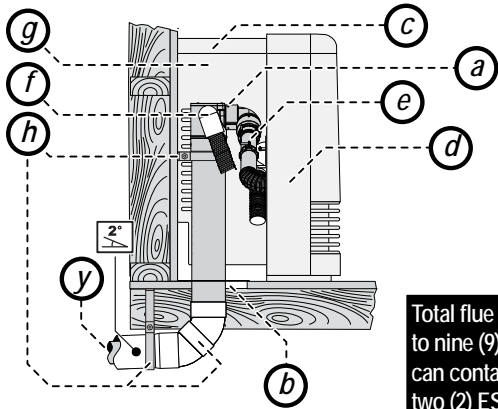

Total flue length can be up to nine (9) metres long and can contain a maximum of two (2) ESBEND (2 x 90°)!

- Activities for creating a Under Floor flue installation:
- Modify ESDFK for Under Floor Installation.
 - Create Penetration in floor.
 - Install side panels of Back Cover Kit (ESBSK).
 - Locate Heater.
 - Connect Heater Exhaust.
 - Connect Combustion Air Hose.
 - Installation and fastening of Back Cover Kit (ESBSK).
 - Cut, Fit & Secure Components (as required).
 - Refer to steps f & g of Direct & Direct Extended (as required).
 - Finalise Installation & Commissioning of Heater.



Flue must not terminate under a building.

Flue terminal is only available in the horizontal format.

Steps for creating a Under Floor flue installation are as follows:

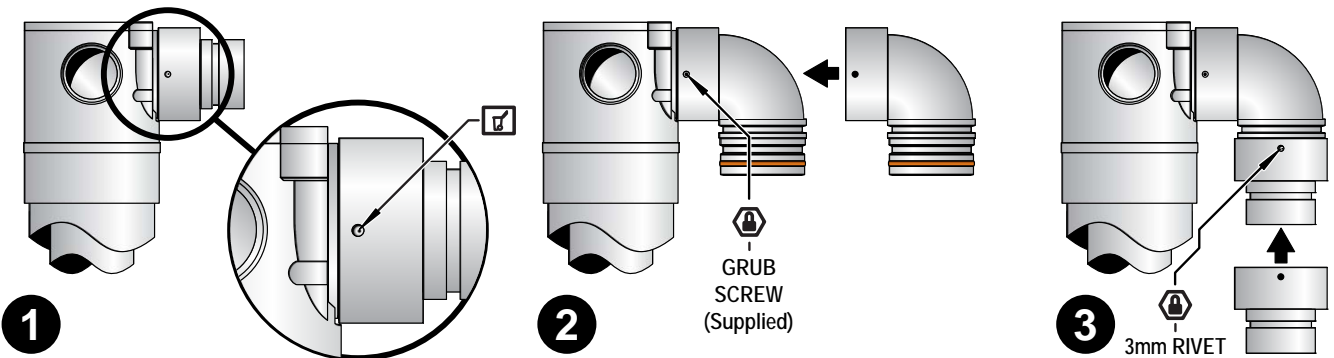

- Using a drill, remove the pop rivet used to fasten the straight flue pipe connection pipe to the flue transition of ESDFK and remove but do not discard the straight flue pipe connection.
- Fit the elbowed flue pipe connection supplied with the back cover kit to the flue transition pushing it fully home and then fasten in place with the grub screw (supplied) using an Allen key. The grub screw terminates in a groove in the flue transition. When fastened this prevents accidental dislodgement of the pipe connections.
- Refit the straight flue pipe connection to the end of the elbow until it is fully home and then fasten in place with a 3mm rivet.



Ensure the straight pipe and elbow are securely fastened to the flue transition by the grub screw and rivets. Test soundness of the connections by attempting to 'pull apart' the assembled components. Improper assembly or fastening can result in products of combustion dispersing into the room being heated which may result in a dangerous condition.

- Attach the side cover panels from the back cover kit (ESBSK A, B, C, D, E or F) to the rear of the heater in accordance with the assembly Instructions supplied with the back cover kit and temporarily position the heater in the desired position.

Check proposed route of down and out flue to confirm there are no obstructions in the flue path.

- Temporarily attach ESDFK to the flue outlet pipe from the rear of the heater. Align the flue in a vertical manner.



Ensure the flue components are positioned to have a minimum 25mm clearance from any sensor wires at the rear of the heater.

FLUE COMPONENT ASSEMBLY

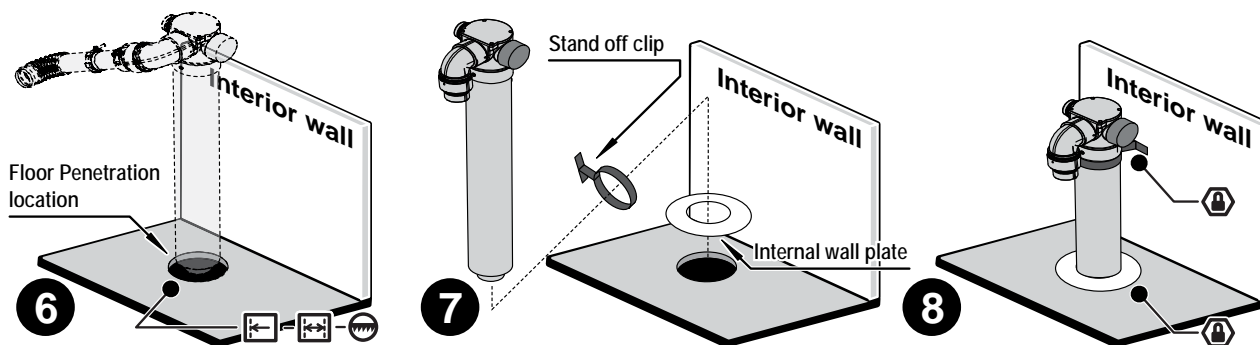

6. Mark the location of the flue floor penetration, then cut an 100mm Ø hole through the floor. Ensure the hole edges are smooth.
7. Disconnect ESDFK from the heater. Pass ESDFK through both a stand off clip and the internal wall plate, then pass the assembly through the floor penetration.
8. Secure ESDFK to the wall with a the stand off clip and fasten the internal wall plate in place to the floor.
9. Prepare the horizontal section of the flue system located under floor by assembling connecting and securing ESPIPE900, ESBEND and subsequent ESPIPE900 lengths as required in accordance with the relevant sections under "COMPONENT ASSEMBLY & CONNECTION ~ ESBEND" refer to page 18 and "COMPONENT ASSEMBLY & CONNECTION ~ ESPIPE900" refer to page 17.



Joints between ESDFK, and ESPIPE900 MUST BE secured by a pop rivet or screw through the outer Co-Ax pipes to prevent accidental or erroneous dislodgement. Pipes are to be clipped using the stand off clips supplied or other suitable method. ESDFK and ESPIPE900 DO NOT require cutting to be joined.

10. Locate the heater in the desired position relative to the wall. **DO NOT** secure the heater at this stage.
11. If required create a wall penetration(s) in accordance with the section "WALL PENETRATIONS" refer to page 6.



Of special relevance to under floor installations is the requirement to have a minimum of 300mm clearance between the flue terminal and the finished ground level. It is not permissible to excavate a hole to obtain the required 300mm clearance, unless there is sufficient drainage provision.

- The minimum diameter required for wall the penetration for ESPIPE900 is 80mm.
- Allow for a continuous 2° fall from the heater connection point to the wall penetration.

12. Create the wall terminal in accordance with "ASSEMBLING WALL TERMINAL ~ ESDFK & ESPIPE900" refer to page 18.
13. Make the heater exhaust and combustion air hose connections in accordance with the section "CONNECTING HEATER EXHAUST & AIR SUPPLY" refer to page 23.



Air hose and heater exhaust connections at the heater MUST be made and checked in accordance with these instructions. Improper connections may result in dangerous situations, for example, the dispersion of combustion products in the space being heated.

14. Install the remaining parts of the back cover kit and fasten the heater and back cover kit to the internal wall surface.
15. Commission the heater in accordance with the manufacturer instructions supplied with the heater.

FLUE COMPONENT ASSEMBLY

CUTTING ~ ESDFK, ESPIPE900 & ESROOFCOWL



Cutting is not required for the purposes of joining ESDFK, ESPIPE900 & ESROOFCOWL together. Cutting of the last component in the flue assembly (the component furthest away from the heater) may be required to achieve the required flue system length. Cutting is also required at a wall penetration. Cutting for both purposes is described below:

Cutting components to achieve a desired length

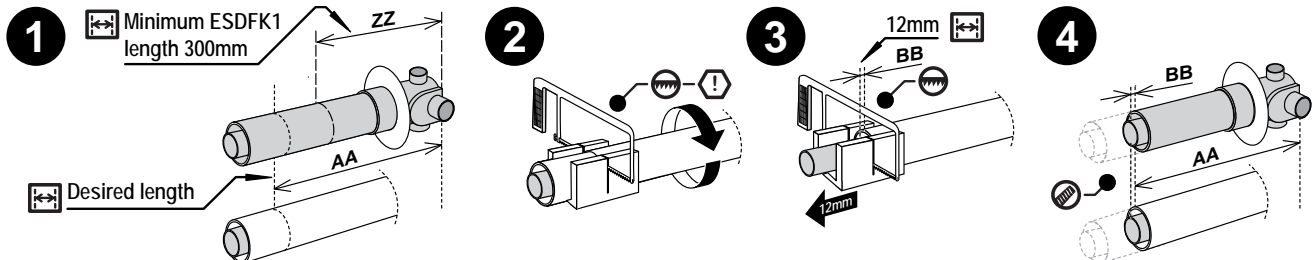

1. Measure and mark off the outer pipe at the desired length (AA).



The minimum length (ZZ) of ESDFK when measured from the back plate of the casting MUST NOT be less than 300mm when joining to other components.

2. Cut the outer pipe to the required length. Take care NOT to cut the inner pipe.
3. From the 'new' end of the outer pipe (cut in Step 2.), measure and mark off an additional 12mm on the inner pipe (BB). Cut the inner pipe at this mark. Take care to keep the cut parallel with that of the outer pipe.
4. Ensure all burrs and swarf are removed from all cut ends.

Cutting components at a wall penetration

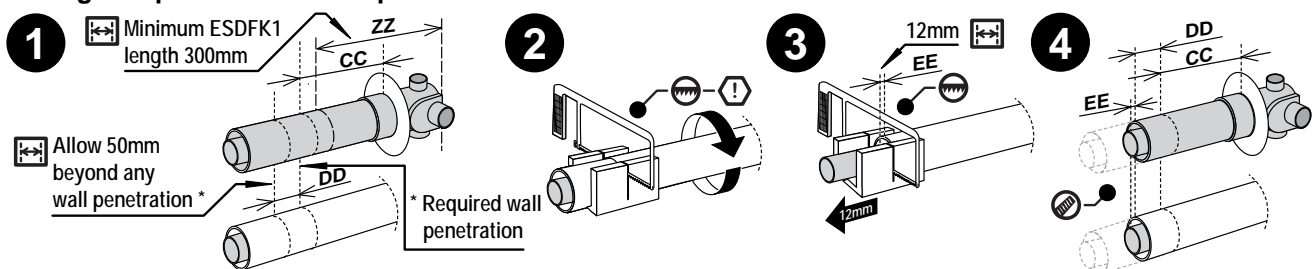

1. Measure and mark off the outer pipe at a point flush with the surface of the wall penetrated (CC) PLUS an additional 50mm (DD).



The minimum length (ZZ) of ESDFK when measured from the back plate of the casting MUST NOT be less than 300mm when joining to other components.

2. Cut the outer pipe to the required length. Take care NOT to cut the inner pipe.
3. From the 'new' end of the outer pipe (cut in Step 2.), measure and mark off an additional 12mm on the inner pipe (EE). Cut the inner pipe at this mark. Take care to keep the cut parallel with that of the outer pipe.
4. Ensure all burrs and swarf are removed from all cut ends.

COMPONENT ASSEMBLY & CONNECTION ~ ESPIPE900

⚠ Lubricate O-Rings with the supplied O-ring grease, then fit the female aluminium inner pipe end over the male inner pipe ends of an adjoining component.



Both the inner and outer pipes of all internal horizontal components MUST BE secured with rivets or screws. The joints of PVC outer pipes that are exposed to an outside environment MUST BE sealed with an appropriate PVC solvent.

FLUE COMPONENT ASSEMBLY

ASSEMBLING WALL TERMINAL ~ ESDFK & ESPIPE900



Flue must terminate in accordance with AS 5601 Figure 5.3. Especially relevant is the requirement to have a minimum of 300mm clearance between the flue terminal and the finished ground level. It is not permissible to excavate a hole to obtain the required 300mm clearance, unless there is sufficient drainage provision.

ONLY the direct flue kit (ESDFK) and the Co-Ax pipe (ESPIPE900) can be modified to create a wall terminal.

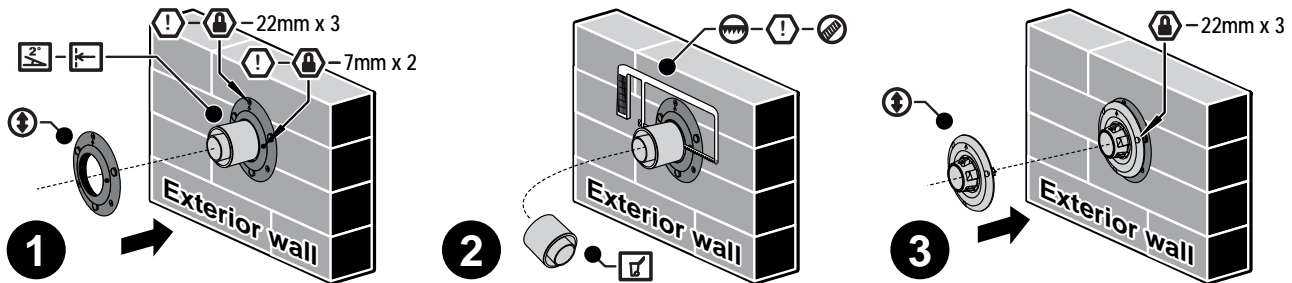

1. Fit the supplied external wall plate over the outer pipe of the flue protrusion.

⚠️ 2° As an installation aid the wall plate has a 2° offset. As such the orientation of the wall plate will set the flue system with either a 2° fall or rise as required. Set the flue system with a 2° fall away from the heater by aligning the arrow symbol so that it is upper most.

⚠️ Once the external wall plate is in the correct position secure it to the wall using the three 22mm screws into the holes provided. ⚠️ The wall plate is then secured to the outer pipe of the flue protrusion using the two horizontal holes and the two 7mm screws provided.

2. ✂️ Carefully cut through the outer and inner pipes of the flue protrusion as close to the external wall plate as possible. ⚠️ Take care to avoid cutting the external wall plate and keep the cuts of both internal and external pipes as parallel as possible. 🌀 All burrs and swarf are to be removed from all cut ends.
3. ⚙️ Align the arrows of the metal mushroom flue terminal and the wall plate to point in the same direction and 🔩 screw the terminal to the external wall plate using the 22mm screws into the holes provided.

ASSEMBLING AN ON-WALL TERMINAL ~ ESWTKIT, ESBEND & ESPIPE900



The creation of an on wall terminal can only be achieved by using a combination of ESWTKIT, ESBEND and ESPIPE900 flue components.

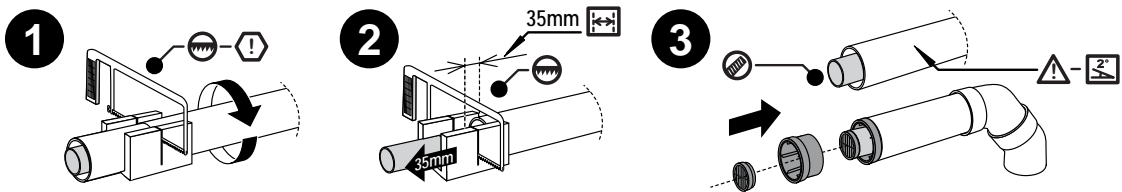

1. 📏 Measure off the required terminal length then mark off for cutting allow an additional 50mm for joining to other components. ✂️ Cut the outer pipe at this mark. ⚠️ Take care to NOT cut the inner pipe while cutting the outer pipe.
2. 📏 From the end of the cut outer pipe measure off an additional 35mm on the inner pipe and mark off for cutting.
3. 🌀 Ensure that burrs and swarf are removed from all cut ends. Attach the pipe spacer to the outer pipe and the flue outlet grill to the inner pipe. ⚠️ 2° When preparing an on wall terminal ensure a continuous 2° fall from the flue termination point back towards the heater (condensate trap).



For the on wall terminal it is CRITICAL that the inner pipe components are secured with rivets or screws and that the joints of PVC outer pipes are sealed with an appropriate PVC solvent.

FLUE COMPONENT ASSEMBLY

COMPONENT ASSEMBLY & CONNECTION ~ ESBEND



ONLY use PVC cement between externally located joints of PVC pipes to secure and seal these joints against ingress of dust and water.

ONLY use non acidic silicone sealant between the joints of 'outer' PVC flue pipes and any mating aluminium components (such as the condensate trap) to secure and seal these joints against ingress of dust and water. Silicone containing acetic acid (vinegar) as the curing agent or other acids may cause corrosion of aluminium components and must not be used.

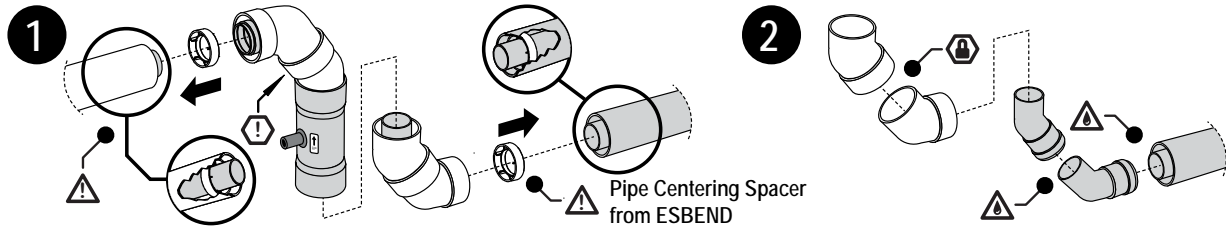

1. A white plastic centering spacer is provided with ESBEND and is required for correct alignment of Co-Axial components. ⚠ The spacer is always positioned inside the component that joins the female end of ESBEND.
2. ⚠ Lubricate ESBEND inner pipe O-Rings and fit to the inner pipe of preceding component.

When fitted correctly the inner and outer pipes of ESBEND will be self centering.



On "Direct", "Direct Extended" and "External Wall" installations 3 ESBEND (3 x 90°) can be used.

On "Sideways", "Under Floor" and "In-Wall" installations 2 ESBEND (2 x 90°) can be used.

COMPONENT ASSEMBLY & CONNECTION ~ ESCONDK



ONLY use non acidic silicone sealant between the joints of 'outer' PVC flue pipes and any mating aluminium components (such as the condensate trap) to secure and seal these joints against ingress of dust and water. Silicone containing acetic acid (vinegar) as the curing agent or other acids may cause corrosion of aluminium components and must not be used.

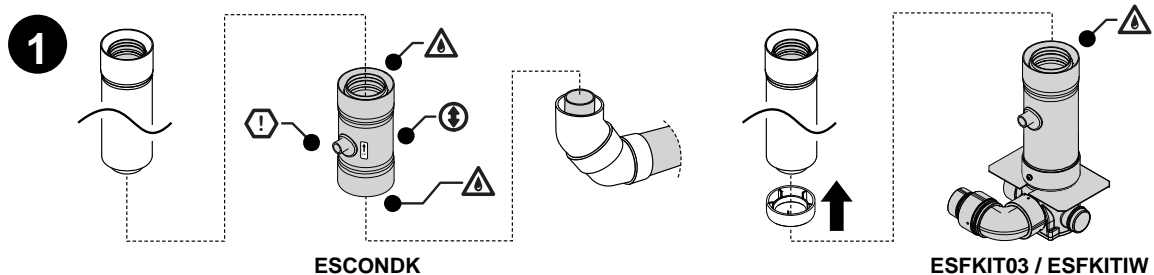

1. ⚠ All "External Wall" and "In-Wall" flue installations must be fitted with ESCONDK.
 - Ⓢ Observe the correct orientation of ESCONDK. The arrow symbol **MUST** point away from the heater towards the termination of the flue system.
 - ⚠ Lubricate all inner pipe O-Rings with the silicone grease provided.



A condensate drain **MUST BE** connected for all In-Wall installations, for details concerning the connecting of the condensate drain see page 22.

COMPONENT ASSEMBLY & CONNECTION ~ ESROOFCOWL

When connecting an ESROOFCOWL to other flue components use the same methods as described for connecting ESPIPE900 and observe the clearance requirements detailed in the section "REGULATIONS, CLEARANCES & GENERAL INFORMATION" refer to page 2.

FLUE COMPONENT ASSEMBLY

CREATING AN "IN-WALL" FLUE INSTALLATION ~ ESKIT03 & ESKITIW

The In-Wall vertical Co-Axial flue system is installed within a stud wall with cavity depth a minimum of 90mm and is run vertically upwards through the stud wall cavity and includes a condensate trap.

When considering the location of the heater due care must be taken to ensure that the flue path in the internal wall and roof space are free of obstructions such as studs, noggins, joists, braces, and electricals etc. A top plate bracket is provided to seal the flue penetration through the top plate.

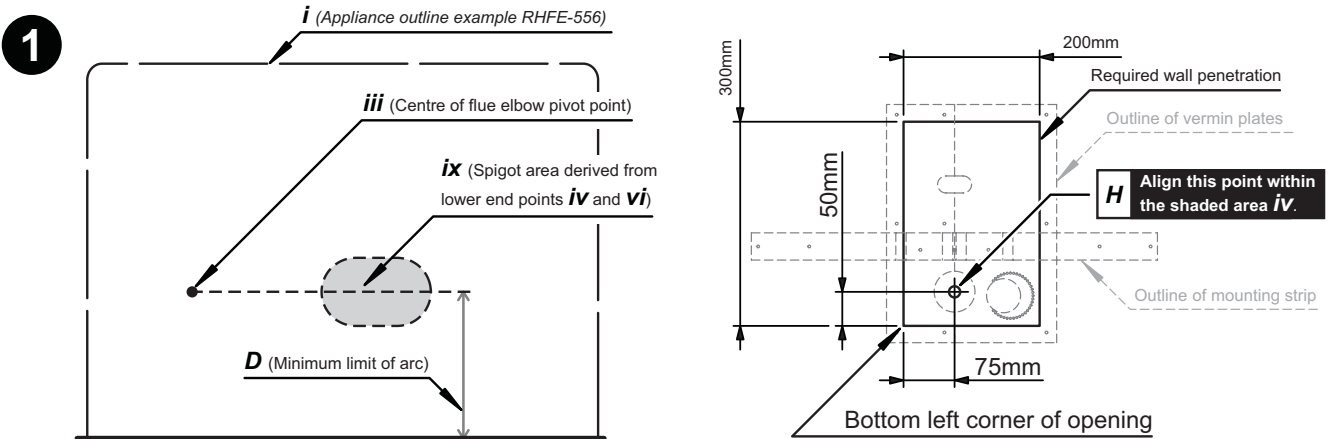

Use in conjunction with section "WALL PENETRATIONS" on page 6.

1. Use the lower end points (**iv** and **vi**) of the flue spigot arc from "WALL PENETRATIONS" on page 6 to determine the shaded spigot area **ix**.

Point **H** is the centre point of the transition casting and the point from which all measurements are taken. The starting point **H** may be placed anywhere within the shaded spigot area **ix**.

Using the dimensions shown above create a 300mm high by 200mm wide opening. The bottom left corner of this opening is 75mm to the left of starting point **H** and 50mm below starting point **H**.

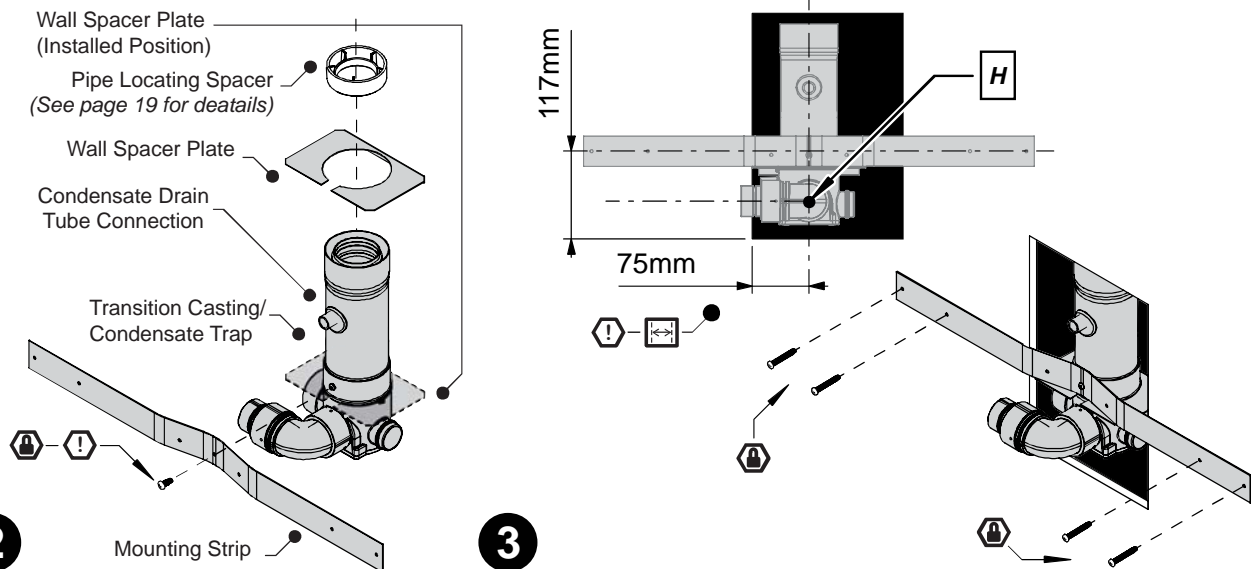

2. ⚠ Remove the screw from the front of the transition casting (retain and do not discard) and slide the wall spacer plate over the transition casting so that the folded tab is facing both down and to the rear.



Using the screw removed from the front of the transition casting attach the mounting strip across the front of the transition casting.



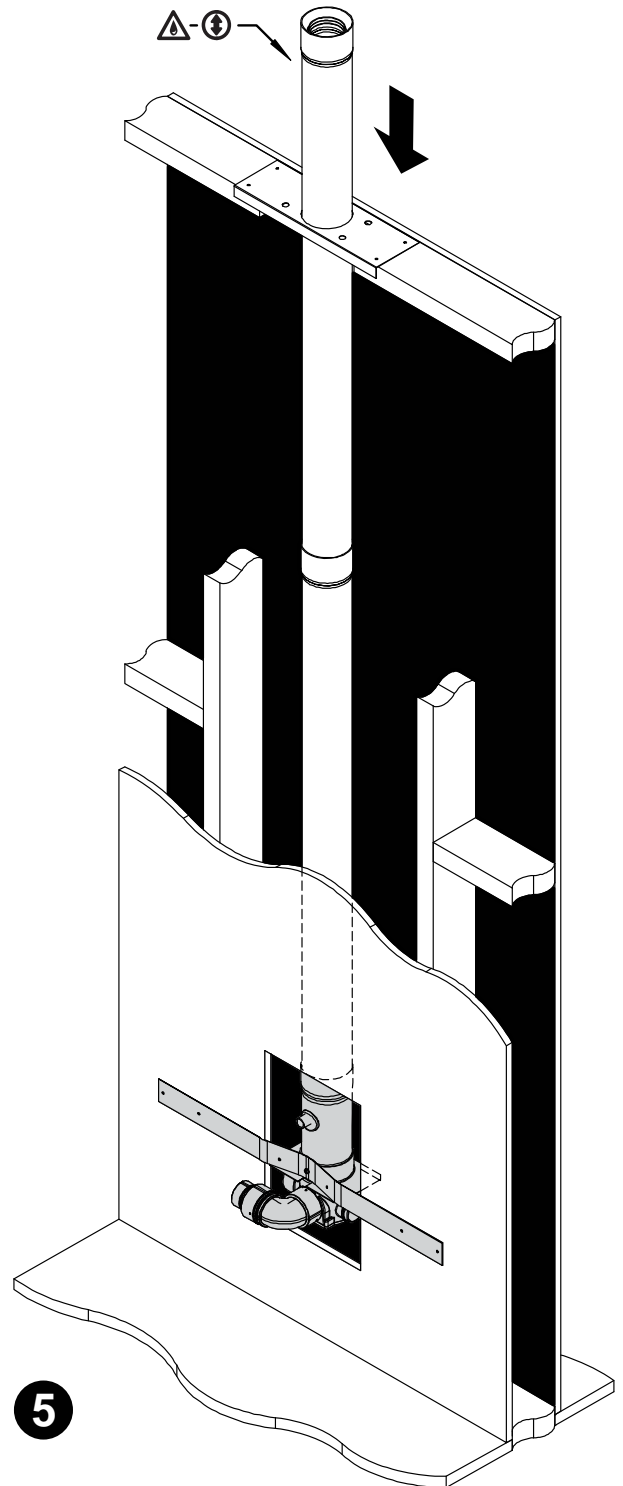
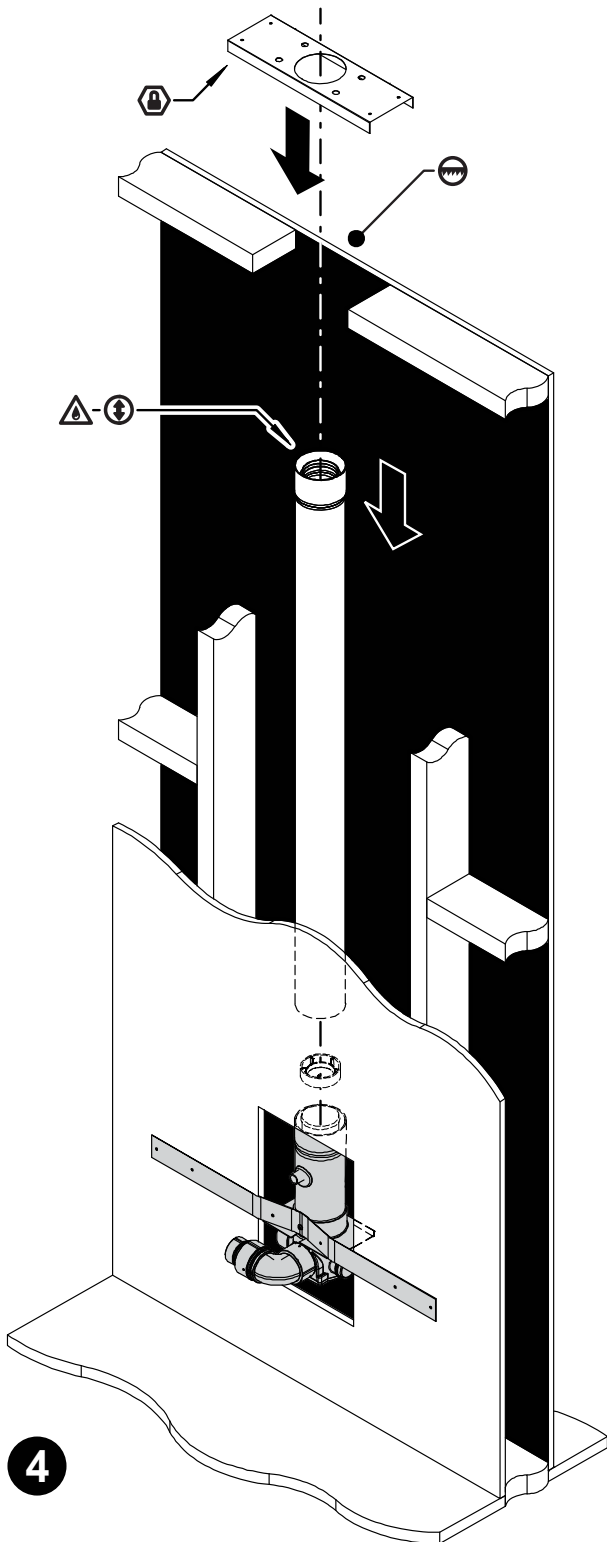

⚠ Lubricate the O-Ring of the condensate trap and attach this to the transition assembly ⚠ ensuring that the drain tube is facing to the front.

3. Install the above assembly in to the wall cavity ⚠ observing the measurements shown to ensure the correct fitting of heater and other components. 🔒 Secure in place with appropriate fixings.

FLUE COMPONENT ASSEMBLY



4.  In the top plate directly above the transition assembly cut a hole for the flue path,  the maximum width **MUST NOT** exceed 150mm. Ensure that the transition assembly is covered to prevent debris entering.

 Lubricate the O-Ring of the condensate trap and  with the male ends pointing towards the heater fit the required lengths of ESPIPE900 to reach but not pass through the top plate,  lubricating the O-Rings of each additional ESPIPE900 length before fitting. When this point is reached  secure the top plate bracket over the hole in the top plate.

5. Continue flueing to the termination point and fit an ESROOFCOWL observing the clearances and regulations refer to page 2. To avoid obstructions in the flue path a horizontal offset can be created using ESBEND.

FLUE COMPONENT ASSEMBLY

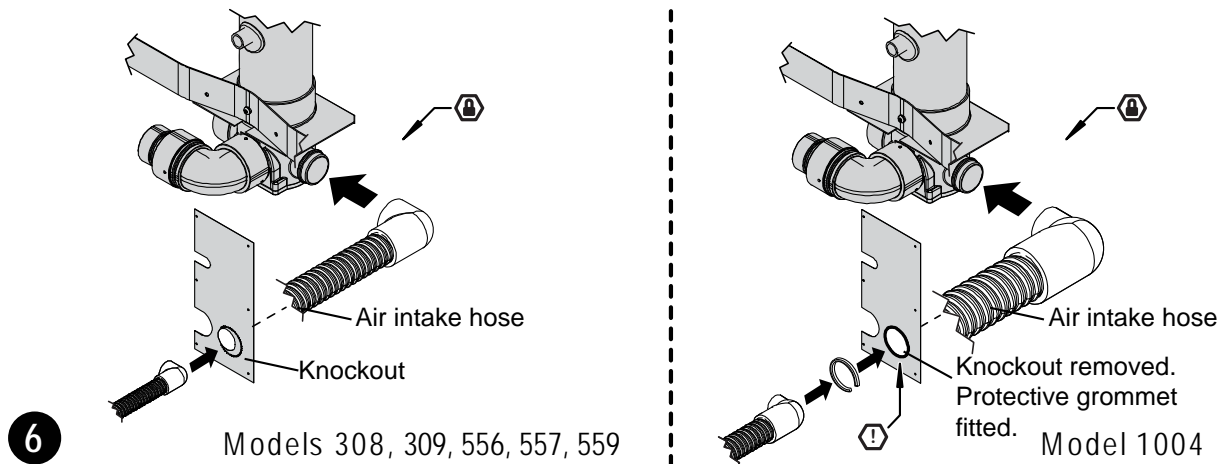

6. Pass the combustion air hose of the heater through the right hand vermin plate.

ⓘ When installing a 1004 model heater the combustion air hose is of a larger diameter. A knockout is provided in the vermin plate that must be removed and a protective grommet fitted before the hose can be passed through the vermin plate.

The combustion air hose for the heater is attached to the large diameter combustion air inlet.



ⓘ Secure the combustion air hose to the combustion air inlet with cable tie supplied with the heater. Air hose connections **MUST BE** made and checked in accordance with these instructions. Improper connections may result in dangerous situations.

The rubber cap (when fitted) is designed to fit both the left and right hand combustion air inlet and **MUST** cover the air inlet not in use.



AT NO TIME MUST THE 'AIR INTAKE' HOSE BE CUT OR SHORTENED.

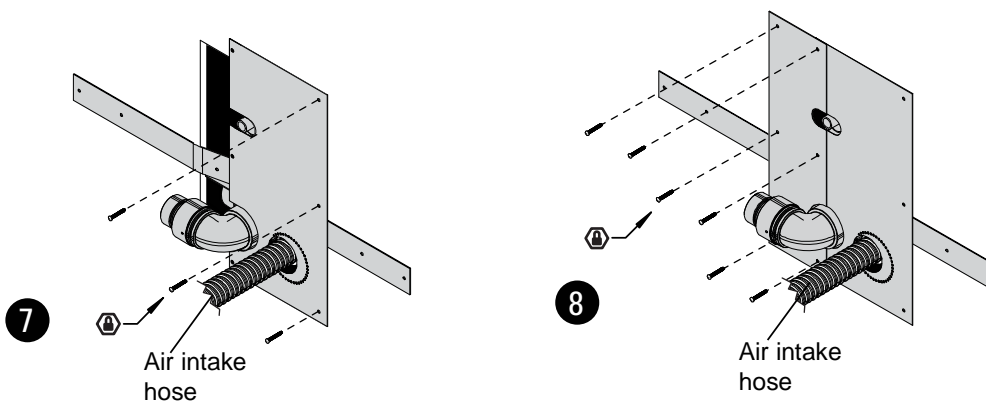

7. Move the right hand vermin plate along the hose until it is flush against the wall, ⓘ then secure in place with three of the nine screws provided.

8. ⓘ Screw the left hand vermin plate to the right hand vermin plate (when overlapped correctly the holes in both plates will be aligned) using three of the nine screws provided. Then use the remaining three of the nine screws provided to fix the remainder of the left hand vermin plate to the wall.

9. Make the heater exhaust connections in accordance with the section "CONNECTING HEATER EXHAUST & AIR SUPPLY" refer to page 23. At no time must the 'Air intake hose' be cut or shortened.



Heater exhaust connections at the heater MUST BE made and checked in accordance with these instructions. Improper connections may result in dangerous situations, for example, the dispersion of combustion products in the space being heated.

10. Install the back cover kit and fasten the heater and back cover kit to the internal wall surface.

11. Commission the heater in accordance with the manufacturer instructions supplied with the heater.

CONNECTING HEATER EXHAUST & AIR SUPPLY

CONNECTING HEATER EXHAUST

This section describes how to connect the exhaust pipe from the Energysaver heater to the exhaust connection on flue transitions of ESDFK and ESKIT03.

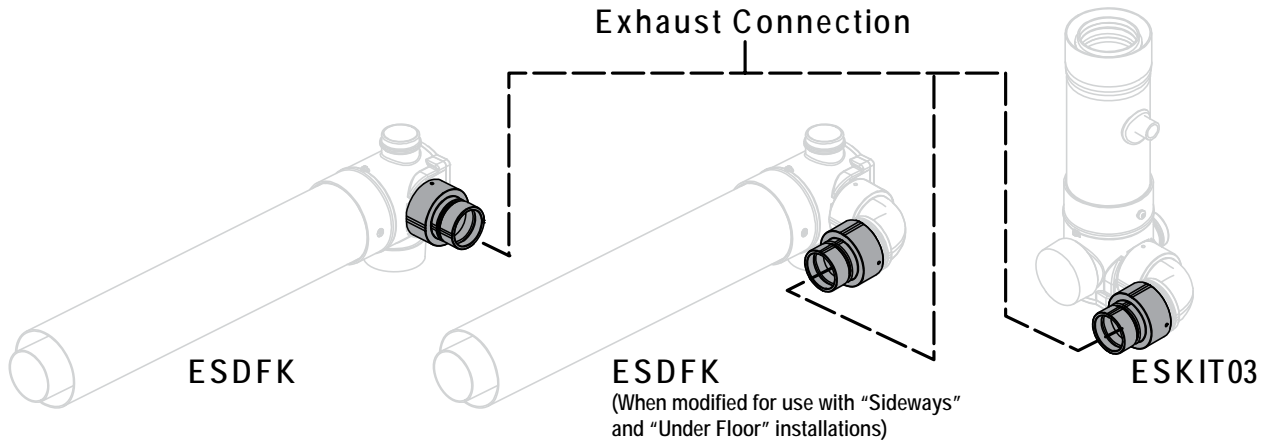

⚠ This joint MUST BE properly secured in accordance with these instructions using the clips provided.

If this joint is not secured properly, products of combustion could disperse into the room being heated which may result in a dangerous condition.

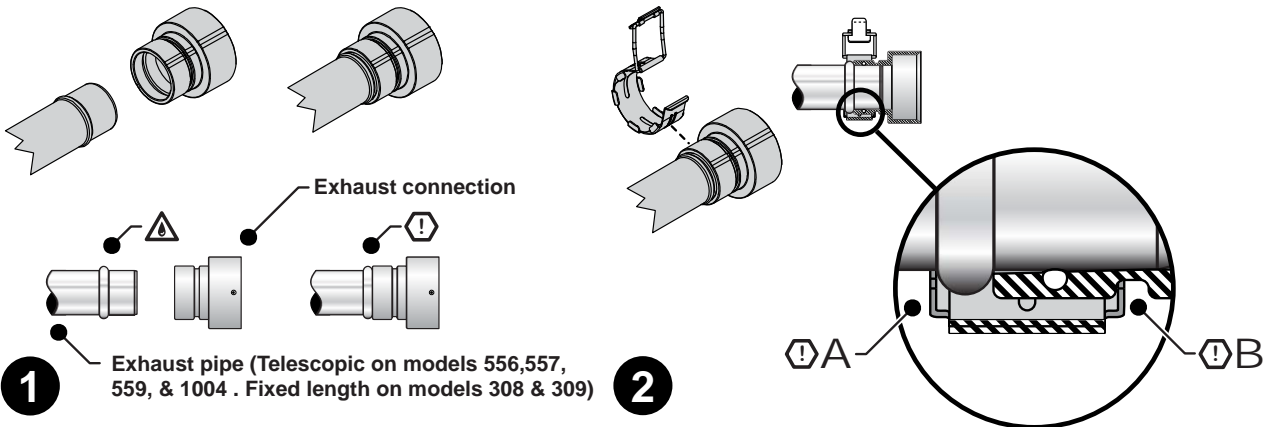

1. **⚠** Lubricate the O-Ring of the exhaust connection and fit to the exhaust pipe of the heater.
⚠ Push the exhaust pipe fully home so that the end of the exhaust connection and the collar of the exhaust pipe are fully mated.



For 1004 models an additional flue component "F Adaptor" is supplied with the heater which steps down the larger diameter heater exhaust to that used by the exhaust connection on the flue system.

2. Attach the flue locking clamp provided with the heater over the exhaust pipe and transition adaptor. Ensure that the teeth of the flue locking clamp engage both **⚠ A** the collar of the exhaust pipe and **⚠ B** the channel in the transition adaptor.

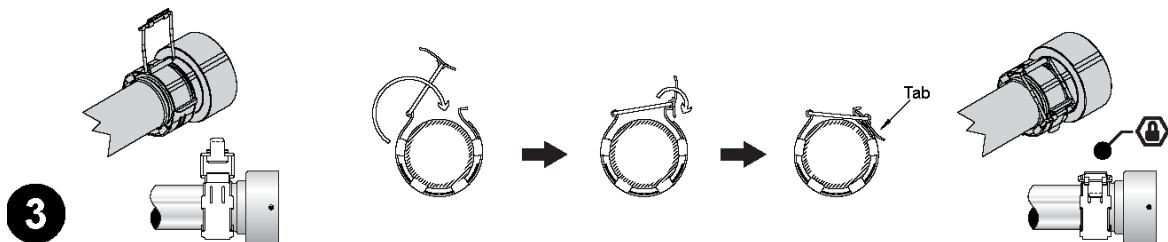

3. **⚠** Close the clamp until the tab locks to secure both components together.

CONNECTING HEATER EXHAUST & AIR SUPPLY



The RHFE-308 and RHFE-309 model heaters have a fixed length non-telescopic exhaust pipe (flue elbow). Steps 4 and 5 are not applicable to installations on these models.

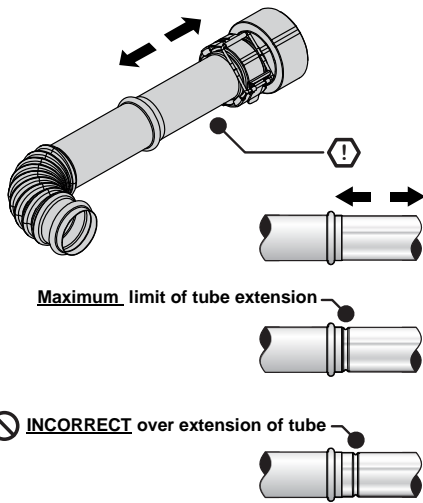

4

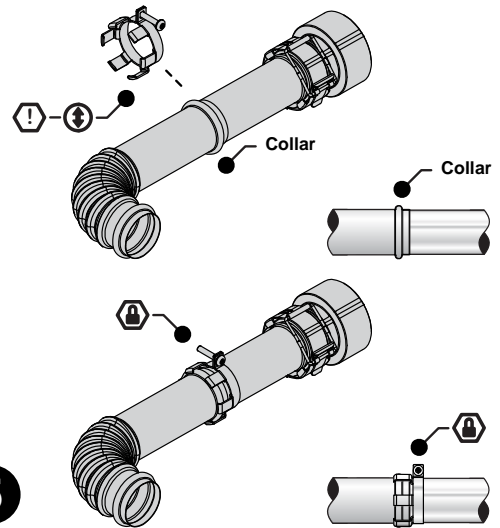

5

- Use the adjustable telescopic tube of the exhaust pipe to attain the desired position of the heater, **DO NOT** extend the telescopic tube beyond the indicator groove.
- Fix the telescopic tube of the exhaust pipe in place with the flue lock. The clamp of the flue lock is attached to the telescopic tube whilst the finger tabs are secured around the collar of the fixed flue spigot.



This joint **MUST BE** properly secured in accordance with these instructions using the flue lock provided.

If the joint is not properly secured, products of combustion could disperse into the room being heated. Which may result in a dangerous condition.

CONNECTING COMBUSTION AIR HOSE (AIR SUPPLY)



Connection of the combustion air hose for a IN-WALL installations is described refer to page 22.

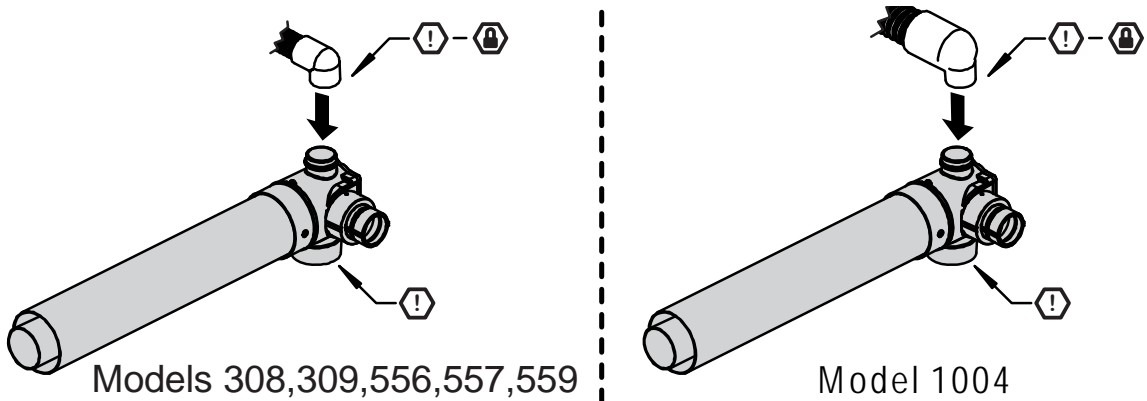

The combustion air hose of all Energysaver heaters is attached to the small diameter combustion air inlet.



Secure the combustion air hose to the combustion air inlet with cable tie supplied with the heater.

The air hose **MUST BE** properly secured in accordance with these instructions for safe and reliable operation of this heater.

The rubber cap (when fitted) is designed to fit both the left and right hand combustion air inlet and **MUST** cover the air inlet not in use.

CONNECTING CONDENSATE DRAIN TUBE TO HEATER

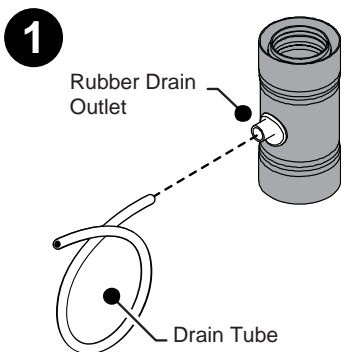

1. Insert one end of the drain tube supplied into the rubber drain outlet of the condensate trap "ESCONDK".
2. Carefully mark and drill a 10mm deep hole in the rear panel in accordance with the model dimensions shown below.



For models RHFE-308, 309, 556, 557, and 559 you must drill through both the raised rear panel as well as the back panel of the heater.

Caution must be taken when drilling to ensure sure not to penetrate deeper than 10mm beyond the back panel of the heater as this may damage internal components, such as the heat exchanger.

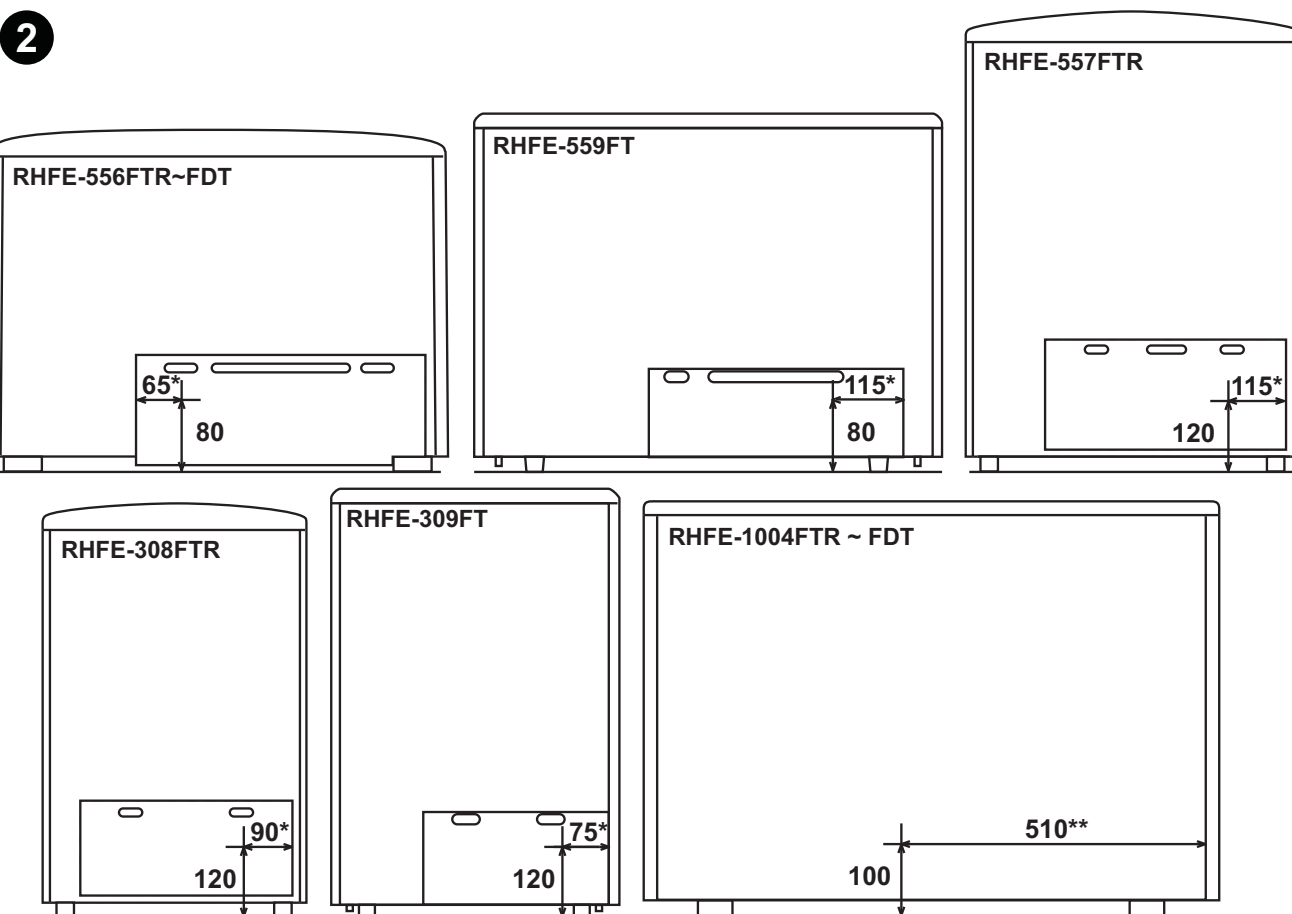

All vertical measurements are from floor level.

* The horizontal measurements for RHFE 308, 309, 556, 557, 559 are taken from the edge of the raised rear panel.

**The horizontal measurement for RHFE 1004 is taken from the inside edge of the back cover kit (or inside edge of rear panel).

3. Feed approximately 60mm of the free end of the drain tube through the hole created in step 2. ensuring that any condensate can drain into the condensate tray of the heater.



DO NOT allow the drain tube to come into to contact with any part of the heat exchanger.

4. Secure the drain tube to the rear of the appliance with a pipe clip.
5. Condensate drain tube and pipe clip are available as a spare part from Rinnai, part number 90180944.

Rinnai

Rinnai Australia Pty. Ltd. ABN 74 005 138 769

Head Office

10-11 Walker Street,
Braeside, Victoria 3195
P.O. Box 460
Tel: (03) 9271 6625
Fax: (03) 9271 6622

Rinnai has a Service and Spare Parts network with personnel who are fully trained and equipped to give the best service on your Rinnai appliance. If your appliance requires service, please call our Service Line. Rinnai recommends that this appliance be serviced every 3 years.

Internet: www.rinnai.com.au E-mail: enquiry@rinnai.com.au

National Help Lines

Sales & Service

Tel: 1300 555 545* Fax: 1300 555 655*

Spare Parts & Technical Info

Tel: 1300 366 388* Fax: 1300 300 141*

**Cost of a local call Higher from mobile or public phones.*

Hot Water Service Line

Tel: 1800 000 340