

Owner's Guide and Installation Instructions



Solar VSi Storage Tank



WARNING: Plumber – Be Aware

Use copper pipe ONLY. Plastic pipe MUST NOT be used.

It is a requirement of a solar water heater installation that all pipe work be in copper and not plastic, due to the effects of high water temperatures.

*This water heater must be installed and serviced by a qualified person.
Please leave this guide with the householder.*



WARNING: Plumber – Be Aware

- The solar hot and solar cold pipes between the solar storage tank and the solar collectors **MUST BE** of copper. All compression fittings must use brass or copper olives.
- The full length of the solar hot and solar cold pipes **MUST BE** insulated.

The insulation must:

- be of a closed cell type or equivalent, suitable for a solar water heating application and capable of withstanding the temperature of the closed circuit fluid generated by the solar collectors under stagnation conditions

The specification of the chosen insulation material should be checked with the insulation manufacturer prior to installation as different materials may vary in temperature tolerance.

- be at least 13 mm thick, however thicker insulation may be required to comply with the requirements of AS/NZS 3500.4
- be weatherproof and UV resistant if exposed
- extend through any penetrations in the eaves, ceiling and roof
- cover valves and fittings in the solar hot and solar cold pipe work
- be fitted up to and cover the connections on both the solar storage tank and the solar collectors.

The insulation will offer corrosion protection to a metal roof against water runoff over the copper pipe, assist in avoiding accidental contact with the solar pipe work as high temperature closed circuit fluid can flow from the solar collectors to the solar storage tank and also reduce pipe heat losses.

- There **must be a continuous fall** of a minimum 5° (1 in 10 grade) in the pipe work between the solar collector and solar storage tank for efficient and effective drain back to occur. The highest point of the solar cold pipe and solar hot pipe must be where they connect to the solar collector.

The system has NO WARRANTY for freeze damage if there is not a continuous fall in the solar hot and solar cold pipes, or they are not insulated in accordance with the installation instructions, or the closed circuit fluid has been incorrectly mixed.

- The insulated copper pipe work:
 - should be fixed at suitable locations to prevent or reduce the possibility of noise from water hammer and vibration from occurring
 - is not to be placed or installed in contact with plastic pipe work.

Likewise, plastic pipe work is not to be placed or installed in contact with the insulated copper pipe work after the solar circuit is installed.

- Plastic pipe **MUST NOT** be used, as it will not withstand the temperature of the closed circuit fluid generated by the solar collector under stagnation conditions. The solar collector can generate extremely high closed circuit fluid temperatures of up to 150°C. Plastic pipe cannot withstand these temperatures and **MUST NOT** be used. Failure of plastic pipe can lead to the release of high temperature closed circuit fluid and cause severe water damage and flooding.
- The pressure applied to the solar circuit and solar collector during a pressure test of an indirect closed circuit system **MUST NOT** exceed 200 kPa, otherwise damage may result to the solar collector. Refer to “[Pressure Testing](#)” on page 37.

PATENTS

This water heater may be protected by one or more patents or registered designs in the name of Rheem Australia Pty Ltd.

TRADE MARKS

® Registered trademark of Rheem Australia Pty Ltd.
™ Trademark of Rheem Australia Pty Ltd.

Note: Every care has been taken to ensure accuracy in preparation of this publication. No liability can be accepted for any consequences, which may arise as a result of its application.

CONTENTS

HOUSEHOLDER – We recommend you read pages 4 to 20.
The other pages are intended for the installer but may be of interest.

About Your Water Heater	4
Regular Care	11
Water Supplies	14
Save A Service Call	17
Installation – Solar Storage Tank	21
Installation – Solar Collector	33
Connections – Plumbing	38
Connections – Electrical	43
Commissioning	46
Draining The Water Heater	60
Warranty	63

 **Warning:** Upon completion of the installation and commissioning of the water heater, leave this guide with the householder or responsible officer. **DO NOT** leave this guide inside of the cover of the water heater, as it may interfere with the safe operation of the water heater or ignite when the water heater is turned on.

ABOUT YOUR WATER HEATER

WATER HEATER APPLICATION

This water heater is designed for use in a single family domestic dwelling for the purpose of heating potable water. Its use in an application other than this may shorten its life.

MODEL TYPE

Your Vulcan® indirect solar VSi water heater is designed for the solar collector to be roof mounted and the solar storage tank to be installed at ground or floor level. The solar storage tank is suitable for installation either indoor or outdoor and with either one only Rheem T200 or two only Rheem NPT200 solar collectors. The system is suitable for installation in areas subject to frost or freeze conditions. Freeze conditions occur below 6°C.

This solar water heater is designed to be installed with either a Vulcan continuous flow 244 020 in-series gas booster mounted onto the storage tank or a Vulcan continuous flow 244 027 in-series gas booster installed remotely. If a 020 model in-series gas booster is mounted onto the storage tank, then it is suitable for outdoor installation only. A 027 model in-series gas booster cannot be mounted on the solar storage tank.

The solar water heater may be installed with another suitable type of remotely installed in-series continuous flow or storage booster. If the in-series water heater is other than a Vulcan continuous flow 244 020 or 244 027 in-series gas booster, then the references to the in-series gas booster in this guide may not be applicable to the installation. For information relating to the function and operation of the in-series water heater, refer to the Owners Guide and Installation Instructions supplied with the water heater.

SOLAR OPERATION

The Vulcan indirect solar VSi water heater has its vitreous enamel lined solar storage tank installed at ground or floor level, remotely from the solar collector. This water heater is an indirect solar hot water system with a heat exchanger in the solar storage tank.

The heat exchanger is filled with closed circuit fluid and is connected to the solar collector by insulated copper pipe work forming a closed circuit. The closed circuit fluid is a solution of a blue, non-toxic food grade propylene glycol concentrate mixed with water. The closed circuit concentrate is used to lower the freezing temperature of the closed circuit fluid and provides protection against freezing.

As the sun heats the solar collector, the increase in temperature activates the pump. The pump switches on whenever the solar collector is hotter than the water in the tank and the water requires heating. The pump moves the closed circuit fluid from the solar storage tank heat exchanger through an insulated copper pipe to the solar collector to be heated by the sun's energy and then back to the heat exchanger. Heat transfers from the closed circuit fluid in the heat exchanger to the water stored in the solar storage tank.

This process continues while solar energy is available and until the water in the solar storage tank reaches a temperature of approximately 75°C. The pump is then deactivated and the closed circuit fluid in the solar collector and solar pipe work drains back into the heat exchanger in the solar storage tank.

The closed circuit provides protection to the solar collector and solar circuit in harsh water areas. The drain back principle provides protection to the system in freezing conditions.

Automatic safety controls are fitted to the water heater to provide safe and efficient operation.

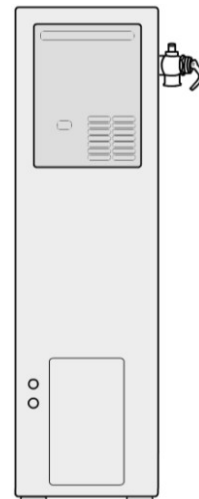
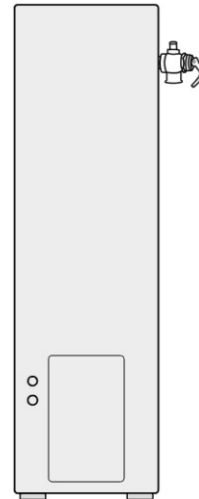

GAS BOOSTING OPERATION

Water stored in the solar storage tank passes through the in-series gas booster when a hot tap is opened. The in-series gas booster is for heating the water at times of low solar energy gain, such as during cloudy or rainy weather, or during colder months.

Solar heated water can reach temperatures up to 75°C in the solar storage tank. When the solar heated water temperature is 58°C or above, the in-series gas booster will not boost the water temperature. When the solar heated water temperature is below 58°C, the gas burners ignite to provide immediate heating of the water to its preset outlet temperature setting. The heat produced by the burner is transferred to the water through the heat exchanger. The water is heated to a constant temperature by the automatic adjustment of the gas supply to the burner to suit the water flow rate. The gas burners extinguish when the hot tap is closed.

If another type of in-series booster water heater is used and the solar heated water temperature is above its thermostat setting, the water heater will not boost the water temperature. When the solar heated water temperature is below the thermostat setting of the water heater, the booster will operate to heat the water.

MAINS PRESSURE

The water heater is designed to operate at mains pressure by connecting directly to the mains water supply. If the mains supply pressure in your area exceeds that [shown on page 24](#), a pressure limiting valve must be fitted. The supply pressure should be greater than 350 kPa for true mains pressure operation to be achieved. The supply pressure should be greater than 140 kPa for the rated flow and performance of a Vulcan in-series gas booster to be achieved.

HOW HOT SHOULD THE WATER BE?

The solar control unit will circulate the closed circuit fluid through the solar collector until a temperature of approximately 75°C is reached in the solar storage tank. During periods of low solar energy gain, the continuous flow in-series gas booster will boost the water temperature automatically to its preset outlet temperature setting, or to the temperature setting of another type of in-series booster water heater.

The factory preset outlet temperature setting of the in-series gas booster is:

- 244 020 60°C
- 244 027 60°C

Note: The preset outlet booster temperature setting of the continuous flow in-series gas booster cannot be adjusted by the householder. The setting can only be adjusted by the installer, Rheem Service or their nearest Accredited Service Agent.

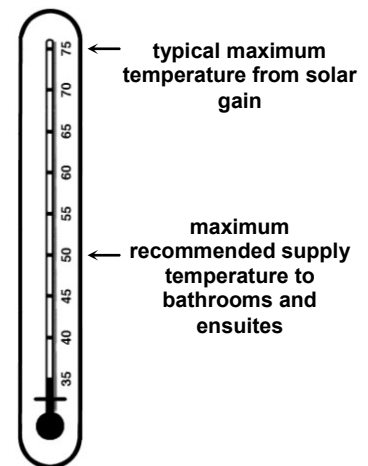

Note: AS 3498 requires that a water heater provides the means to inhibit the growth of Legionella bacteria in potable water. If this water heater is installed with an continuous flow in-series gas booster, then this requirement of AS 3498 can be satisfied provided the booster is energised, its preset outlet temperature setting is 70°C or higher and a remote temperature controller is not used.

If this water heater is installed with an in-series storage booster, then this requirement of AS 3498 can be satisfied provided the storage booster is energised and its thermostat setting is 60°C or higher.

⚠ Warning: Temperature controllers **must not** be fitted to the in-series booster as part of a solar water heater system because water at a temperature much higher than the controller setting can be delivered.

HOTTER WATER INCREASES THE RISK OF SCALD INJURY

This water heater can deliver water at temperatures which can cause scalding. Check the water temperature before use, such as when entering a shower or filling a bath or basin, to ensure it is suitable for the application and will not cause scald injury.

We recommend and it may also be required by regulations that an approved temperature limiting device be fitted into the hot water pipe work to the bathroom and ensuite when this water heater is installed. This will keep the water temperature below 50°C at the bathroom and ensuite. The risk of scald injury will be reduced and still allow hotter water to the kitchen and laundry.

⚠ WARNING

This water heater is only intended to be operated by persons who have the experience or the knowledge and the capabilities to do so. This water heater is not intended to be operated by persons with reduced physical, sensory or mental capabilities i.e. the infirm, or by children. Children should be supervised to ensure they do not interfere with the water heater.

This water heater uses 240 V AC electrical power for operation of the control systems and the electrically operated components. The removal of the front covers will expose 240 V wiring. They must only be removed by a qualified person. The power leads from the solar storage tank and in-series gas booster must be plugged into weatherproof electrical outlets. Take care not to touch the power plug with wet hands.

Care should be taken not to touch the pipe work connecting the solar storage tank and the solar collector. Very high temperature closed circuit fluid can be generated by the solar collector under certain conditions and flow through the pipe work from the solar collector to the solar storage tank.

Should the water from the water heater appear blue or if blue closed circuit fluid is noticed around the base of the water heater, this indicates a leak of the closed circuit fluid from the heat exchanger. The closed circuit fluid is non-toxic and not hazardous to health. Phone Rheem Service or their nearest Accredited Service Agent to arrange for an inspection.

SAFETY

The solar storage tank is supplied with temperature sensors, a pressure relief valve and a combination temperature pressure relief valve. The in-series gas booster is supplied with temperature sensors, a FlameSafe™ protection system and a pressure relief valve. These devices must not be tampered with or removed. The water heater must not be operated unless each of these devices is fitted and is in working order.

If the power supply cord or plug to the solar storage tank or in-series gas booster is damaged, it must be replaced by a qualified person in order to avoid a hazard. The power supply cord and plug must be replaced with a genuine replacement part available from Rheem. Phone Rheem Service or their nearest Accredited Service Agent to arrange for an inspection.

⚠ Warning: For continued safety of this water heater it must be installed, operated and maintained in accordance with the Owner's Guide and Installation Instructions.

The Vulcan warranty may not cover faults if relief valves or other safety devices are tampered with or if the installation is not in accordance with these instructions.

- Do not store **flammable or combustible materials** near the water heater. Flammable liquids (such as petrol), newspapers and similar articles must be kept well away from the water heater and the flue terminal.
- Do not use **aerosols, stain removers and household chemicals** near the water heater whilst it is working. Gases from some aerosol sprays, stain removers and household chemicals become corrosive when drawn into a flame.
- Do not store swimming pool chemicals, household cleaners, etc., near the water heater.
- Do not place anything on top of the water heater or in contact with the flue terminal. Ensure the flue terminal is not obstructed in any way at any time.
- Do not use Propane / Butane gas mixtures in a Propane model. A Propane model is designed to operate on Propane only. The use of Propane / Butane mixture, such as automotive LPG fuel, in a Propane model is unsafe and can cause damage to the water heater.



PIPE WORK AND INSULATION

The solar hot and solar cold pipes between the solar storage tank and the solar collectors and the pipe work between the solar storage tank and a remote in-series water heater **MUST BE** of copper.

The full length of the solar hot and solar cold pipes **MUST BE** insulated. The insulation must:

- be of a closed cell type or equivalent, suitable for a solar water heating application and capable of withstanding the temperatures of the fluid generated by the solar collectors under stagnation conditions
- be at least 13 mm thick, however thicker insulation may be required to comply with the requirements of AS/NZS 3500.4
- be weatherproof and UV resistant if exposed
- extend through any penetrations in the eaves, ceiling and roof
- cover valves and fittings in the solar hot and solar cold pipe work
- be fitted up to and cover the connections on both the solar storage tank and the solar collectors.

The insulation will offer corrosion protection to a metal roof against water runoff over the copper pipe, assist in avoiding accidental contact with the solar pipe work as high temperature closed circuit fluid can flow from the solar collectors to the solar storage tank and also reduce pipe heat losses.

There must be a continuous fall in the pipe work from the solar collector to the solar storage tank. The continuous fall is essential to assist in the drain back function of the solar system.

Plastic pipe **MUST NOT** be used, as it will not withstand the temperature of the closed circuit fluid generated by the solar collector under certain conditions (refer to [Warning on page 35](#)).

FREEZE PROTECTION

Solar Circuit

The solar circuit must be installed with a continuous fall of a minimum 5° (1 in 10 grade) in the pipe work from the solar collector to the solar storage tank, with the full length of the solar hot and solar cold pipes insulated and the system charged with correctly mixed closed circuit fluid to offer protection against freeze damage. The system has NO WARRANTY for freeze damage if there is not a continuous fall in the solar hot and solar cold pipes, or they are not insulated in accordance with the installation instructions, or the closed circuit fluid has been incorrectly mixed (refer to [“Terms of the Vulcan Warranty”](#) on page 63 and to [“Pipe Work and Insulation”](#) on page 7).

The anti freeze control of the solar circuit is designed so there is no closed circuit fluid in the solar collector or solar cold and solar hot pipes when the pump is off.

Gas Booster Water Heater

The in-series gas booster has a frost protection system. The frost protection system will protect the in-series gas booster from damage, by preventing ice forming in the waterways of the gas booster, in the event of freezing conditions occurring.

Notes:

- The in-series gas booster frost protection system will be rendered inoperable if electrical power is not available at the gas booster. Damage caused by freezing due to the unavailability of power at the in-series gas booster is not covered by the Vulcan warranty (refer to [“Terms of the Vulcan Warranty”](#) on page 63).
- If it is necessary to switch the power off to the in-series gas booster and there is a risk of freezing, then it is necessary to drain the gas booster (refer to [“Draining the Gas Booster Water Heater”](#) on page 9).
- Pipe work to and from the in-series gas booster must be adequately insulated to prevent freezing.
- The water heater is not suitable for installation in areas where the ambient temperature falls below -20°C (including wind chill factor).
- Refer to [“Terms of the Vulcan Warranty”](#) on page 63.

SOLAR MONITOR

The solar storage tank incorporates a solar monitor. The solar monitor is located above the lower front cover and houses both a green and a red LED.

The green LED, marked “Solar”, indicates the current operational mode of the solar water heater and the red LED, marked “Attention”, indicates a fault mode.

The green LED will emit either a constant glow or a series of flashes, with a 2 second interval between each series.

The red LED will emit a series of flashes, with a 2 second interval between each series, only if there is a particular fault condition with the system.

The operational modes are:

Flashes	Operational Modes
solid green (remains on)	Standby mode
2 x green	Flooding solar circuit
3 x green	Pump flow control
4 x green	Pump flow established
5 x green	Tank at maximum temperature
no green (remains off)	Call for service

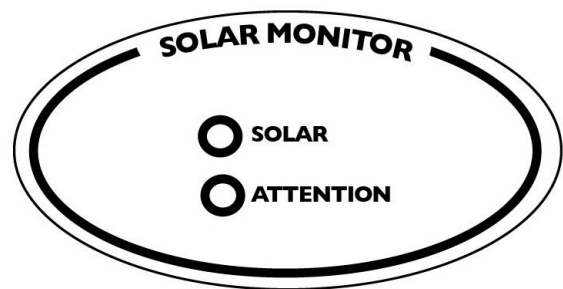

If the power supply to the water heater is on and the green LED is off or the red LED is flashing, this indicates there is a fault with the water heater. The red LED may emit up to six flashes in each series of flashes. Count the number of flashes and phone Rheem Service or their nearest Accredited Service Agent to arrange for an inspection.

RAIN WATER TANK

If the solar collector and solar pipe work are installed on a section of roof which is part of a rain water runoff collection system, then it is recommended this section of roof and its gutter be isolated from the rain water collection system. The gutter should be isolated to a width greater than the solar collector and pipe work and must have suitable drainage. This is to ensure in the event of a leak from the solar collector or pipe work, a rainwater tank cannot be contaminated with closed circuit fluid.

The closed circuit fluid contains food grade additives (rust inhibitor and anti-freeze agent), is non-toxic and is harmless to the environment. However, if it enters a rain water tank, it can kill off microscopic algae which are typically present in the water causing an unpleasant odour to develop and resulting in the rain water tank having to be drained and cleaned.

PRECAUTIONS

Where damage to property can occur in the event of the water heater leaking, the water heater must be installed in a safe tray. Construction, installation and draining of a safe tray must comply with AS/NZS 3500.4 and all local codes and regulatory authority requirements.

The water heater must be maintained in accordance with the Owner's Guide and Installation Instructions. Refer to ["Regular Care"](#) on page 11 and to ["Anode Inspection and Replacement"](#) on page 15.

If this water heater is to be used where an uninterrupted hot water supply is necessary for your application or business you should ensure that you have back up redundancy within the hot water system design. This should ensure the continuity of hot water supply in the event that this water heater were to become inoperable for any reason. We recommend you seek advice from your plumber or specifier about your needs and building back up redundancy into your hot water supply system.

TO TURN OFF THE WATER HEATER

If you plan to be away from home for a few nights, we suggest you leave the water heater switched on.

If it is necessary to turn off the water heater:

- Switch off the electrical supply at the power outlets to the solar storage tank and to the in-series gas booster if there is no risk of freezing conditions occurring (refer to note below).
- Close the gas isolation valve at the inlet to the water heater.
- Close the cold water isolation valve at the inlet to the water heater.

Note: If there is a risk of freezing conditions, the electrical supply to the in-series gas booster should not be switched off unless the gas booster is drained, otherwise damage could result (refer to “Freeze Protection” on page 7 and “Draining the Gas Booster Water Heater” on page 9).

TO TURN ON THE WATER HEATER

- Screw in the drain plugs at the cold water inlet and hot water outlet of the in-series gas booster if the gas booster has been drained.
- Open the cold water isolation valve fully at the inlet to the water heater.
- Open all of the hot water taps in the house (don't forget the shower).

Air will be forced out of the taps.

- Close each tap as water flows freely from it.
- Open the gas isolation valve fully at the inlet to the water heater.
- Plug in the solar storage tank and gas booster at the power outlets and switch on the electrical supplies.

The power outlets must be switched on for the solar controls to operate and solar gain to be achieved and for the in-series gas booster to operate.

The in-series gas booster will operate automatically when you open a hot tap, if boosting is required.

DRAINING THE GAS BOOSTER WATER HEATER

- Turn off the water heater (refer to “Turn Off The Water Heater” on page 9).
- Open a hot tap (preferably the shower outlet).
- Unscrew the two drain plugs, one each at the cold water inlet and hot water outlet, on the underside of the in-series gas booster.

Water will drain from the in-series gas booster.

- When water stops flowing from the in-series gas booster, close the hot tap.

Note: It is recommended not to screw the drain plugs back in, until the water heater is to be turned on again.

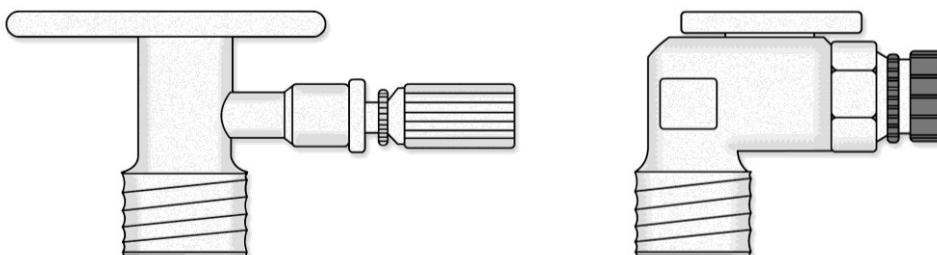

GOING ON HOLIDAYS

It is not necessary to switch off the electrical supply at the power outlets to the solar storage tank and in-series gas booster if you are going away. However, if it is necessary to switch off the power to the water heater, refer to [“To Turn Off The Water Heater”](#) on page 9. If the power to the water heater is switched off and there is a risk of freezing, then it is necessary to drain the in-series gas booster (refer to [“Draining the Gas Booster Water Heater”](#) on page 9).

HOW DO I KNOW IF THE WATER HEATER IS INSTALLED CORRECTLY?

Installation requirements are [shown on pages 21 to 32](#). The water heater must be installed:

- by a qualified person, and
- in accordance with the installation instructions, and
- in compliance with Standards AS/NZS 3500.4, AS/NZS 3000, AS 5601 or AS/NZS 5601.1, as applicable under local regulations, and all local codes and regulatory authority requirements.

In New Zealand, the installation must also conform with NZS 5261, as applicable under local regulations, and Clause G12 of the New Zealand Building Code.

⚠ Warning: Temperature controllers **must not** be fitted to the in-series booster as part of a solar water heater system because water at a temperature much higher than the controller setting can be delivered.

Refer also to [“Pipe Work and Insulation”](#) on page 7, and to [“Rain Water Tank”](#) on page 8.

VICTORIAN CUSTOMERS

Notice to Victorian Customers from the Victorian Plumbing Industry Commission. This water heater must be installed by a licensed person as required by the Victorian Building Act 1993.

Only a licensed person will give you a Compliance Certificate, showing that the work complies with all the relevant Standards. Only a licensed person will have insurance protecting their workmanship for 6 years. Make sure you use a licensed person to install this water heater and ask for your Compliance Certificate.

DOES THE WATER CHEMISTRY AFFECT THE WATER HEATER?

The water heater is suitable for most public water supplies, however some water chemistries may have detrimental effects on the water heater, components and fittings. Refer to [“Water Supplies”](#) on page 14.

If you are in a known harsh water area or you are not sure of your water chemistry, have your water checked against the conditions [described on pages 14 to 16](#).

HOW LONG WILL THE WATER HEATER LAST?

The water heater is supported by a manufacturer’s warranty ([refer to page 63](#)). There are a number of factors that will affect the length of service the water heater will provide. These include but are not limited to the water chemistry, the water pressure, the water temperature (inlet and outlet) and the water usage pattern. Refer to [“Precautions”](#) on page 8.

REGULAR CARE

GENERAL MAINTENANCE

The jacket of the gas booster can be cleaned with a soft cloth and warm mild soapy water. Under no circumstances should abrasive materials or powders be used.

The area around the gas booster can be sprayed with insecticide to rid the area of insects. Insects encroaching into or nesting in the water heater can interfere with the operation of the gas booster and also damage components.

COLLECTOR GLASS

Ensure the glass on your solar collector is free of dust, salt spray or any other matter, which may reduce the effectiveness of the solar collector. If the collector glass becomes dirty, hose down or if the solar collector is accessible, wash the collector glass with water and a soft brush when the solar collector is cool.

Have any trees trimmed which may shade the solar collector.

Rheem solar collectors have passed the AS/NZS 2712 requirements for resistance to hailstone damage, so it is not normally necessary to fit a guard to a collector. Stone Guards are available to provide a level of protection to the solar collectors against vandalism or accidental damage. Refer to your local Solar Distributor for details.

MINOR SIX MONTH MAINTENANCE

It is recommended minor maintenance be performed every six months by the dwelling occupant.

The minor maintenance includes:

- Operate the easing lever on the temperature pressure relief valve. It is very important you raise and lower the lever gently. Refer to "[Temperature Pressure Relief Valve](#)" on page 13.

⚠ Warning: Exercise care to avoid any splashing of water, as water discharged from the drain line will be hot. Stand clear of the drain line's point of discharge when operating the valve's lever.

- Operate the easing lever on the expansion control valve (if fitted). It is very important you raise and lower the lever gently. Refer to "[Expansion Control Valve](#)" on page 12.
- Check the drain line from the safe tray (if one is installed) is not blocked.
- Inspect around the air inlet, flue terminal and the gas booster in general for plant growth.
 - Trim back any shrubs, bushes or other plants which have encroached around the gas booster.
Plant growth across the air let and flue terminal can interfere with the performance of the gas booster.
- Inspect around the gas booster for insect infestations, such as ants.
 - Spray insecticide around the gas booster if necessary to rid the area of insects. Do not spray the surface or into the air inlet or flue terminal of the gas booster.
Insects encroaching into or nesting in the gas booster can interfere with the operation of the gas booster and also damage components.

MAJOR FIVE YEAR SERVICE

For safe and efficient operation, it is recommended a major five year service be conducted on the water heater.

⚠ Warning: Servicing of a water heater must only be carried out by a qualified person. Phone Rheem Service or their nearest Accredited Service Agent.

Note: The five year service and routine replacement of any components, such as the anodes and relief valves, are not included in the Vulcan warranty. A charge will be made for this work. Only genuine replacement parts should be used on this water heater.

The major service includes the following actions:

- Replace the temperature pressure relief valve.
- Inspect and flush the expansion control valve (if fitted). If required, replace the valve.
- Inspect and if required, replace the anodes.

If an anode is not replaced, it should be replaced within three years of this service (refer to [“Anode Inspection and Replacement”](#) on page 15).

- Check the system for correct operation.
- Check the closed circuit fluid level.
- Clean the collector glass.
- Visually check the unit for any potential problems.
- Check and if necessary adjust the gas pressure.
- Check the operation of and clean the burner.
- Inspect all connections.
- Check the drain line from the safe tray (if one is installed) is not blocked.

Note: The solar storage tank may need to be drained during this service. After the completion of the service, the solar storage tank will take some time to reheat the water by solar gain.

EXPANSION CONTROL VALVE

In many areas, including South Australia, Western Australia and scaling water areas, an expansion control valve is fitted to the cold water line to the water heater. The expansion control valve may discharge a small quantity of water from its drain line during the heating period instead of the temperature pressure relief valve on the water heater.

Operate the easing lever on the expansion control valve once every six months. **It is very important you raise and lower the lever gently.** The expansion control valve should be checked for performance or replaced at intervals not exceeding 5 years, or more frequently in areas where there is a high incidence of water deposits.

TEMPERATURE PRESSURE RELIEF VALVE

This valve is near the top of the water heater and is essential for its safe operation. It is possible for the valve to release a little water through the drain line during each heating period. This occurs as the water is heated and expands by approximately 1/50 of its volume.

Continuous leakage of water from the valve and its drain line may indicate a problem with the water heater (refer to “[Temperature Pressure Relief Valve Running](#)” on page 19).

⚠ Warning: Never block the outlet of this valve or its drain line for any reason.

Operate the easing lever on the temperature pressure relief valve once every six months. **It is very important you raise and lower the lever gently.**

⚠ Warning: Failure to do this may result in the water heater cylinder failing.

⚠ Warning: Exercise care to avoid any splashing of water, as water discharged from the drain line will be hot. Stand clear of the drain line’s point of discharge when operating the valve’s lever.

If water does not flow freely from the drain line when the lever is lifted, then the water heater must be checked. Phone Rheem Service or their nearest Accredited Service Agent to arrange for an inspection.

The temperature pressure relief valve should be replaced at intervals not exceeding 5 years, or more frequently in areas where there is a high incidence of water deposits (refer to “[Water Supplies](#)” on page 14).

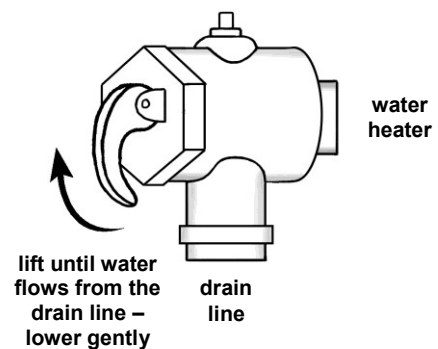
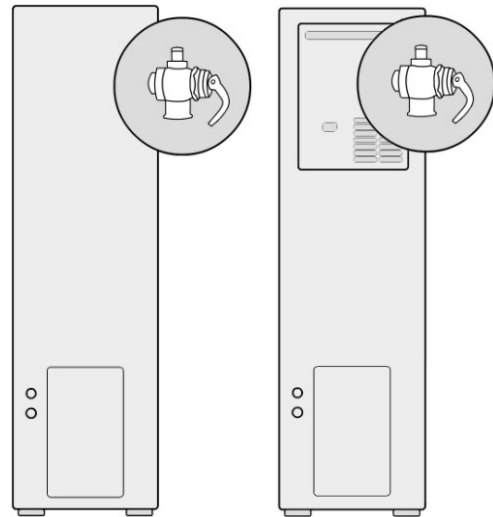

WATER SUPPLIES

This water heater must be installed in accordance with this advice to be covered by the Vulcan warranty.

This water heater is manufactured to suit the water conditions of most public reticulated water supplies. However, there are some known water chemistries which can have detrimental effects on the water heater and its operation and / or life expectancy. If you are unsure of your water chemistry, you may be able to obtain information from your local water supply authority. This water heater should only be connected to a water supply which complies with these guidelines for the Vulcan warranty to apply.

CHANGE OF WATER SUPPLY

The changing or alternating from one water supply to another can have a detrimental effect on the operation and / or life expectation of a water heater cylinder, a temperature pressure relief valve and a continuous flow water heater heat exchanger.

Where there is a changeover from one water supply to another, e.g. a rainwater tank supply, bore water supply, desalinated water supply, public reticulated water supply or water brought in from another supply, then water chemistry information should be sought from the supplier or it should be tested to ensure the water supply meets the requirements given in these guidelines for the Vulcan warranty to apply.

ANODE

The vitreous enamel lined cylinder of the water heater is only covered by the Vulcan warranty when the total dissolved solids (TDS) content in the water is less than 2500 mg/L and when the correct colour coded anode is used. If an incorrect colour coded anode is used in the water heater, any resultant faults will not be covered by the Vulcan warranty. In addition, the use of an incorrect colour coded anode may shorten the life of the water heater cylinder.

The correct colour coded anode must be selected and fitted to the water heater in accordance with the following advice and the [Anode Selection chart](#) on page 14 for the Vulcan warranty to apply to the water heater cylinder.

Total Dissolved Solids	Anode colour code
0 – 40 mg/L	Green
40 – 150 mg/L	Green or Black
150 – 400 mg/L	Black
400 – 600 mg/L	Black or Blue
600 – 2500 mg/L	Blue
2500 mg/L +	Blue (no cylinder warranty)

The changing of an anode must be carried out by a qualified person.

Note: Some water analysis reports may state the conductivity of the water rather than the level of total dissolved solids. Conductivity, measured in microsiemens per centimetre ($\mu\text{S} / \text{cm}$), is directly proportional to the TDS content of the water. TDS, in mg / L, is approximately 70% of the conductivity in $\mu\text{S} / \text{cm}$.

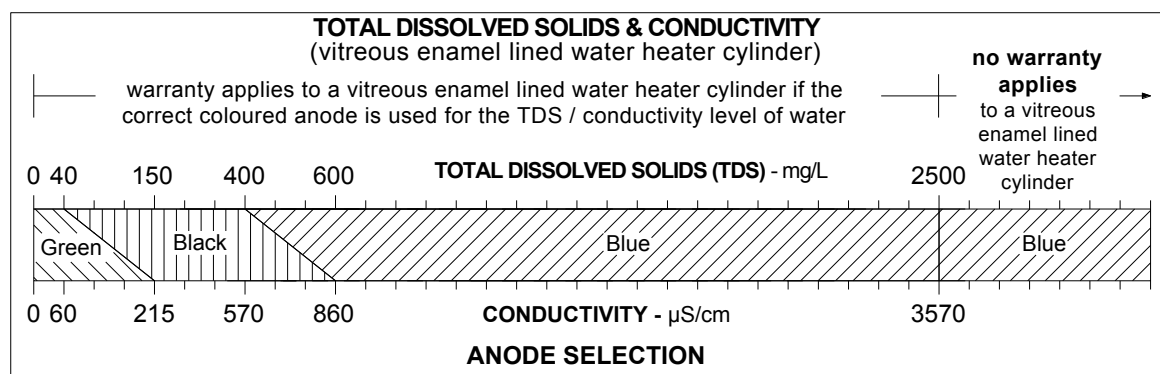

ANODE INSPECTION AND REPLACEMENT

The anode installed in a vitreous enamel lined steel water heater cylinder will slowly dissipate whilst protecting the cylinder. The life of the cylinder may be extended by replacing the anode.

If the anode is not replaced during a five year service (refer to [“Major Five Year Service”](#) on page 12) then the maximum time after installation when the anode should be replaced is 8 years.

For water supplies which are either softened, desalinated or where the water supply may alternate between a water tank and a reticulated public supply or another supply, it is recommended the anode be replaced within 5 years of installation.

CAUTION

If the water supply has a TDS greater than 150 mg/L and a green anode has not been changed to a black anode, or if the TDS is greater than 600 mg/L and the anode has not been changed to a blue anode, there is the possibility the anode may become overactive and hydrogen gas could accumulate in the top of the water heater during long periods of no use.

If, under these conditions, the water heater has not been used for two or more weeks the following procedure should be carried out before using any electrical appliances (automatic washing machines and dishwashers) which are connected to the hot water supply.

The hydrogen, which is highly flammable, should be vented safely by opening a hot tap and allowing the water to flow. There should be no smoking or naked flame near the tap whilst it is turned on. Any hydrogen gas will be dissipated. This is indicated by an unusual spurting of the water from the tap. Once the water runs freely, any hydrogen in the system will have been released.

SATURATION INDEX

The saturation index is used as a measure of the water's corrosive or scaling properties.

In a corrosive water supply, the water can attack copper parts and cause them to fail.

Where the saturation index is less than -1.0 , the water is very corrosive and the Vulcan warranty does not apply to a continuous flow water heater heat exchanger.

In a scaling water supply calcium carbonate is deposited out of the water onto any hot metallic surface.

Where the saturation index exceeds $+0.40$, the water is very scaling. An expansion control valve must be fitted on the cold water line after the non-return valve to protect and for the Vulcan warranty to apply to the temperature pressure relief valve and water heater cylinder.

Where the saturation index exceeds $+0.80$, the Vulcan warranty does not apply to a continuous flow water heater heat exchanger.

Water which is scaling may be treated with a water softening device to reduce the saturation index of the water.

Refer to the [Saturation Index chart](#) on page 16.

Refer to the [cold water connection detail on page 38](#) for the position of the expansion control valve.

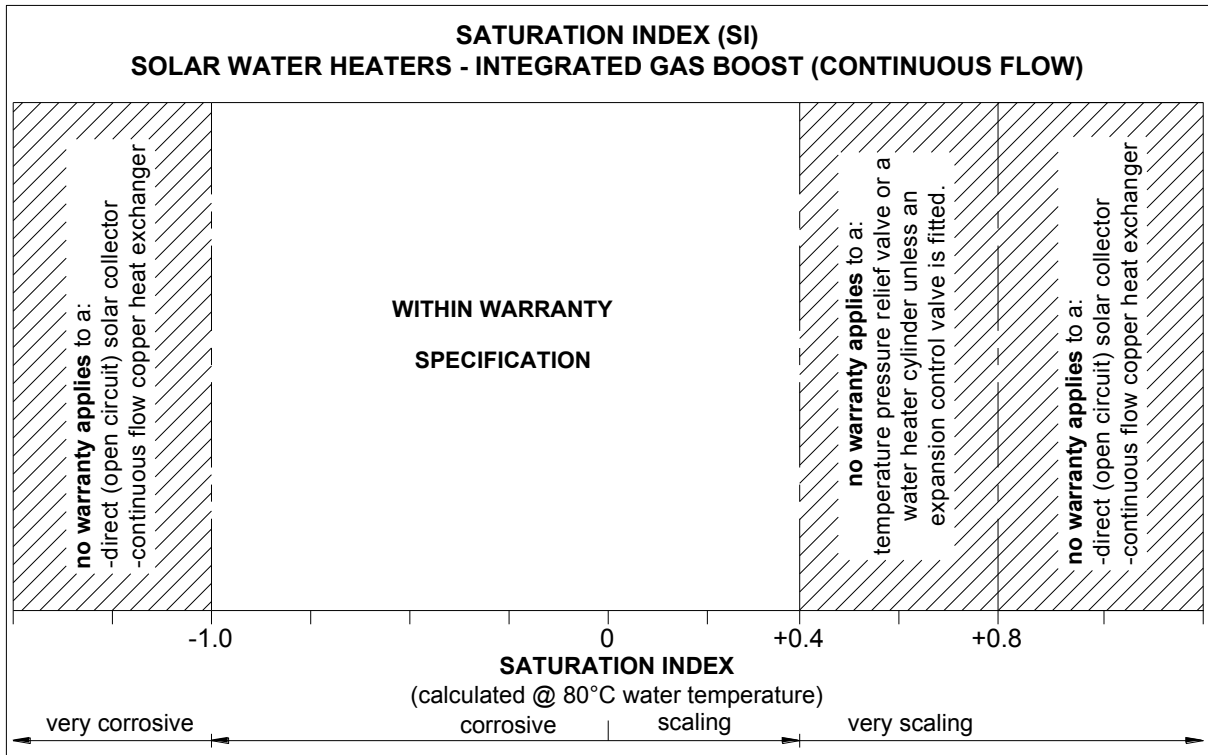

SUMMARY OF WATER CHEMISTRY ADVICE AFFECTING WARRANTY

The water heater, solar collectors and their components are not suitable for certain water chemistries. Those chemistries are listed below. If the water heater is connected at any time to a water supply with the following water chemistry, the Vulcan warranty will not cover any resultant faults on the components listed below:

Water Chemistry

- Total Dissolved Solids (TDS) > 2500 mg/L
- Total Dissolved Solids (TDS) not suitable for anode type
- Saturation Index (SI) < -1.0
- Saturation Index (SI) > +0.4 (if an expansion control valve is not fitted)
- Saturation Index (SI) > +0.8

Component

- water heater cylinder
- water heater cylinder
- gas booster copper heat exchanger
- temperature pressure relief valve, water heater cylinder
- gas booster copper heat exchanger

SAVE A SERVICE CALL

Check the items below before making a service call. You will be charged for attending to any condition or fault that is not related to manufacture or failure of a part.

COLD WATER FROM THE HOT TAP

- Close the hot tap, wait 10 seconds and open the hot tap again.
- Is the hot tap open enough?

The in-series gas booster burners will not light if the flow rate is less than 2.5 L / min (244 series).

- **Solar control unit and in-series gas booster not operating**

- Check the power supply cords are plugged in and the power outlets switched on.
- Is power available in the house?
Try using another electrical appliance.

- **Gas supply**

- Is the isolation valve in the gas line open?
- Is there a gas supply to the rest of the house?
Try lighting another gas appliance.
- Has the gas line been purged of air after installation?
Refer to your plumber.

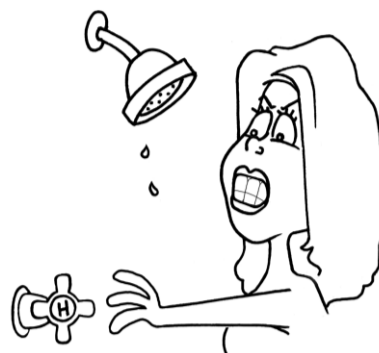

NO WATER FROM THE HOT TAP

No flow of water from the hot tap may indicate a restriction in or failure of the cold water supply to the water heater. Check for water flow at other taps and that the cold water isolation valve ([refer to page 38](#)) is fully open.

WATER FLOW FLUCTUATES

More than one or two hot taps (020 models) or more than two or three taps (027 models) in use at the same time may cause a decrease in the hot water flow from the taps. This can be evident with an in-series gas booster to a solar water heater and the solar heated water is at a low temperature.

- Are there more than one or two hot taps (020 models) or more than two or three taps (027 models) open, or are appliances such as a dishwasher or washing machine, in use at the same time?
Ensure only one or two hot taps or appliances (020 models) or only two or three taps or appliances (027 models) are on at the one time.
- Check the flow of the water from one tap, e.g. the shower.
The shower should be adjusted so the hot tap is fully open.

IN-SERIES BOOSTER OPERATING TOO FREQUENTLY

You may find that the in-series booster operates more frequently than expected. This will occur when the solar heated water temperature is lower than 58°C for the 244 020 or 244 027 in-series gas booster or lower than the temperature setting of another type of in-series booster, which may be experienced during periods of low solar energy gain or if there has been heavy hot water usage. Factors to consider are:

- **Hot tap not used recently**

If a hot tap has not been used for a while, the water in the pipe work between the solar storage tank and the in-series gas booster may have cooled down. The in-series gas booster will sense the cooler water and this will cause the burners on the water heater to ignite and boost the water temperature when a hot tap is first turned on. The burners will extinguish when solar heated water of 58°C or higher from the solar storage tank reaches the in-series gas booster (refer also to [“Fan Continues to Run after Water Heater Operation Stops”](#) on page 18).

- **Insufficient sunlight**

Insufficient sunlight due to cloudy weather during hotter months or low solar energy contribution in colder months may mean the in-series gas booster operates more often.

- **Collector shaded**

If trees or other objects shade the solar collector or if the glass is dirty, the effectiveness of the solar collector will be greatly reduced. Have the trees trimmed or the solar collector relocated if the obstruction is permanent or clean the collector glass (refer to [“Collector Glass”](#) on page 11).

- **Are you using more hot water than you think?**

Is one outlet (especially the shower) using more hot water than you think?

Very often it is not realised the amount of hot water used, particularly when showering. Carefully review the family’s hot water usage. As you have installed an energy saving appliance, energy saving should also be practised in the home. Adjust your water usage pattern to take advantage of maximum solar gains.

Have your plumber install a flow control valve to each shower outlet, basin and sink to reduce water usage.

- **Temperature pressure relief valve running**

Is the relief valve discharging too much water?

Refer to [“Temperature Pressure Relief Valve Running”](#) on page 19.

- **Water heater size**

Do you have the correct size water heater for your requirements?

The sizing guide in the sales literature suggests average sizes that may be needed.

- **Green LED is off or red LED is flashing on Solar Monitor**

If the green LED is off or the red LED is flashing on the Solar Monitor label, there may be a problem with the solar water heater operation and solar gain is not being achieved. This will result in the in-series gas booster operating to provide all of the hot water required.

Switch off the electrical supply at the power outlet to the solar storage tank for a few seconds, then switch on again.

If the green LED remains off or the red LED recommences to flash, then count the number of flashes and phone Rheem Service or their nearest Accredited Service Agent to arrange for an inspection.

FAN CONTINUES TO RUN AFTER WATER HEATER OPERATION STOPS

It is the normal operation of the in-series gas booster for the fan to continue running after heating of the water is finished. The fan may run for up to six minutes after the burners extinguish, to prepare for the next ignition.

COLLECTOR GLASS

The Vulcan warranty **DOES NOT** cover breakage of solar collector glass. Check your household insurance policy covers collector glass breakage.

⚠ Warning: No attempt should be made to remove or replace broken collector glass.

The collector glass is not offered as a replacement part. Should the solar collector require replacement, contact Rheem Service or their nearest Accredited Service Agent.

TEMPERATURE PRESSURE RELIEF VALVE RUNNING

- **Normal Operation**

It is normal and desirable this valve allows a small quantity of water to escape during the heating cycle. However, if it discharges more than a bucket full of water in 24 hours, there may be another problem.

- **Continuous dribble**

Try gently raising the easing lever on the relief valve for a few seconds (refer to “Temperature Pressure Relief Valve” on page 13). This may dislodge a small particle of foreign matter and clear the fault. Release the lever gently.

- **Steady flows for long period (often at night)**

This may indicate the mains water pressure sometimes rises above the designed pressure of the water heater. Ask your installing plumber to fit a pressure limiting valve.

⚠ Warning: Never replace the relief valve with one of a higher pressure rating.

- **Heavy flows of hot water until the water heater is cold - then stops until water reheats**

The water heater **must** be switched off at the isolating switch or switchboard. Phone Rheem Service or their nearest Accredited Service Agent to arrange for an inspection.

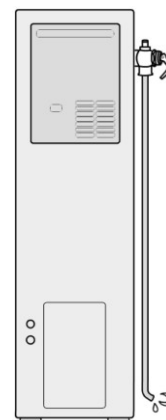
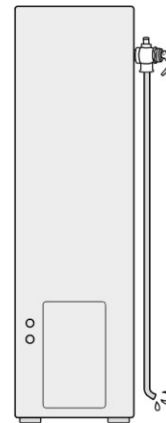

EXPANSION CONTROL VALVE RUNNING

If an expansion control valve is fitted in the cold water line to the water heater (refer to page 38) it may discharge a small quantity of water instead of the temperature pressure relief valve on the water heater. The benefit is that energy is conserved as the discharged water is cooler.

PRESSURE RELIEF VALVE DISCHARGING

A pressure relief valve is incorporated into the in-series gas booster controls. This valve protects the in-series gas booster, by allowing water to escape, in the event of excessive pressure build up in the waterways.

- **Normal operation**

A small volume of water may discharge from the bottom of the in-series gas booster when a hot tap is suddenly closed.

- **Continuous dribble**

A continuous dribble may indicate the water supply pressure is above the design pressure for the in-series gas booster. If so, a pressure limiting valve must be installed on the cold water supply pipe to the water heater (refer to “Mains Water Supply” on page 24).

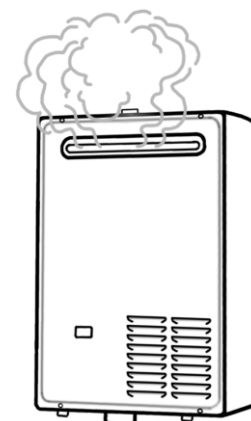

CLOUDS OF WHITE ‘VAPOUR’ FROM THE FLUE TERMINAL

During the heating cycle, it is not unusual to see water vapour clouds steaming from the flue terminal, particularly on cold days. This is normal operation of the in-series gas booster.

ERROR CODE

The in-series gas booster provides a diagnostic error code in the event of an interruption to its operation. The error code is displayed on the front of the in-series gas booster on the OK MONITOR as a numerical value on the 244 027 models or a series of flashes on the 244 020 models. If an error code appears:

- Close the hot tap and switch off the electrical supply to the in-series gas booster.
- Wait 5 minutes, then switch on the electrical supply to the in-series gas booster and open a hot tap.

If the error code persists, take note of the numerical value (027 model) or the number of flashes (020 model) and turn off the hot tap. Phone Rheem Service or their nearest Accredited Service Agent to arrange for inspection.



HIGHER THAN EXPECTED ENERGY BILLS

With the installation of your new solar hot water system, maximum energy savings can be achieved with careful planning of hot water usage. Should you at any time feel your energy account is higher than expected, we suggest you check the following points:

- Is the relief valve running excessively?
Refer to [“Temperature Pressure Relief Valve Running”](#) on page 19.
- Is one outlet (especially the shower) using more hot water than you think?

Refer to [“In-Series Booster Operating Too Frequently”](#) on page 18.

- Is there a leaking hot water pipe, dripping hot water tap, etc?
Even a small leak will waste a surprising quantity of hot water and energy. Replace faulty tap washers, and have your plumber rectify any leaking pipe work.

- Is the in-series gas booster operating too frequently?
Refer to [“In-Series Booster Operating Too Frequently”](#) on page 18.

- Has there been an increase in hot water usage?
An increase in hot water usage may result in an increase in booster operation.

- Has your water heating tariff rate been increased by your energy retailer since your previous account?



IF YOU HAVE CHECKED ALL THE FOREGOING AND STILL BELIEVE YOU NEED ASSISTANCE, PHONE RHEEM SERVICE OR THEIR NEAREST ACCREDITED SERVICE AGENT.

INSTALLATION – SOLAR STORAGE TANK

THIS WATER HEATER IS FOR OUTDOOR INSTALLATION IF AN IN-SERIES GAS BOOSTER IS MOUNTED ON THE STORAGE TANK.

THIS WATER HEATER IS NOT SUITABLE FOR POOL HEATING.

**Check the in-series gas booster is suitable for the gas type available.
(refer to the rating label on the in-series gas booster)**

The system is suitable for installation with either one Rheem T200 or two Rheem NPT200 solar collectors.

IMPORTANT NOTES

- Working on roofs is and should always be considered a hazardous activity, particularly early in the morning, late in the evening, when the roof is wet and during and after periods of rain.
- All work must be carried out in accordance with Local, State and Federal Occupational Safety, Health and Welfare Regulations. In particular, the requirements for safety whilst manual lifting, working at heights and on roofs.
- Installers must be competently trained in:
 - Height Hazard Assessment
 - Working at Height Procedures
 - Assessment / Use / Wearing of correct height safety equipment (harnesses etc.)
 - All other relevant safety factors specific to the installation and maintenance work to be compliant with suitable Occupational, Health and Safety Regulations / Codes.
- All relevant permits shall be obtained from the regulatory authorities before commencing work to install the solar hot water system.
- All work carried out must be performed by appropriately qualified tradespeople or be suitably supervised for trades assistant duties.
- Every care must be taken to protect and warn occupants of the building and the public from personal injury which may occur from falling tools, roof materials, fittings or any other hazards of a general nature.
- Advise the occupants of any inconvenience which may occur due to disconnection of existing water and electrical supplies.
- The connection, attachment, integration or general association of other equipment or parts which either directly or indirectly affect the operation or performance of this equipment could void the Vulcan warranty.
- All packaging materials must be removed from the solar storage tank prior to its installation. This includes the removal of the cardboard base of the carton from the underside of the solar storage tank.

INSTALLATION STANDARDS

The water heater must be installed:

- by a qualified person, and
- in accordance with the installation instructions, and
- in compliance with Standards AS/NZS 3500.4, AS/NZS 3000, AS 5601 or AS/NZS 5601.1, as applicable under local regulations, and all local codes and regulatory authority requirements.

In New Zealand, the installation must also conform with NZS 5261, as applicable under local regulations, and Clause G12 of the New Zealand Building Code.

⚠ Warning: Temperature controllers **must not** be fitted to an in-series gas booster as part of a solar water heater system because water at a temperature much higher than the controller setting can be delivered.

Victorian Installers

Notice to Victorian Installers from the Victorian Plumbing Industry Commission if this solar water heater is installed in a new Class 1 dwelling in the State of Victoria. The system model number is to be recorded on the Certificate of Compliance. It is also a requirement to provide the householder with permanent documentation recording the system model number exactly as it is shown in the 'List of systems capable of complying with the regulations' published by Sustainability Victoria (see www.sustainability.vic.gov.au). This documentation may be in the form of an indelible label adhered to the solar storage tank, or other suitable form placed in an accessible location, such as the meter box, for later inspection.

WATER HEATER APPLICATION

This water heater is designed for use in a single family domestic dwelling for the purpose of heating potable water. Its use in an application other than this may shorten its life.

If this water heater is to be used where an uninterrupted hot water supply is necessary for the application or business, then there should be redundancy within the hot water system design. This should ensure the continuity of hot water supply in the event that this water heater was to become inoperable for any reason. We recommend you provide advice to the system owner about their needs and building backup redundancy into the hot water supply system.

This solar water heater is designed to be installed with either a Vulcan continuous flow 244 020 in-series gas booster mounted onto the storage tank or installed remotely or a Vulcan continuous flow 244 027 in-series gas booster installed remotely.

⚠ Warning: A 027 model in-series gas booster cannot be mounted on the solar storage tank and may only be installed remotely. The size and weight of the gas booster may cause the solar storage tank to topple over.

The solar water heater may be installed with another suitable type of remotely installed in-series continuous flow or storage booster. If the in-series water heater is other than a Vulcan continuous flow 244 020 or 244 027 in-series gas booster, then the references to the in-series gas booster in this guide may not be applicable to the installation. For information relating to the function and operation of the in-series water heater, refer to the Owners Guide and Installation Instructions supplied with the water heater.

Note: AS 3498 requires that a water heater provides the means to inhibit the growth of Legionella bacteria in potable water. If this water heater is installed with an continuous flow in-series gas booster, then this requirement of AS 3498 can be satisfied provided the booster is energised, its preset outlet temperature setting is 70°C or higher and a remote temperature controller is not used.

If this water heater is installed with an in-series storage booster, then this requirement of AS 3498 can be satisfied provided the storage booster is energised and its thermostat setting is 60°C or higher.

SOLAR WATER HEATER STORAGE TANK LOCATION

The solar storage tank is suitable for indoor or outdoor installation. If an in-series gas booster is mounted onto the storage tank, then the installation must be outdoors. The solar storage tank should be installed close to the most frequently used outlet and its position chosen with safety and service in mind. Make sure people (particularly children) will not touch the flue terminal of an in-series gas booster. The flue terminal and air inlet must be clear of obstructions and shrubbery.

Consideration must also be given to the position of the solar storage tank in relation to the solar collector. There are limitations on both the maximum length of the solar hot and solar cold pipes and the maximum height between the solar storage tank and the solar collector. Refer to "[Solar Collector Location](#)" on page 33 and to "[Pipe Lengths](#)" on page 34.

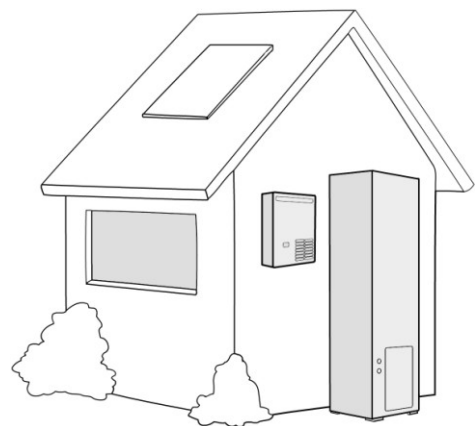

Clearance must be allowed for servicing of the solar storage tank and in-series gas booster. The solar storage tank must be accessible without the use of a ladder or scaffold. Make sure the temperature pressure relief valve lever is accessible and the front panel and front covers can be removed for service.

You must be able to read the information on the rating plate. If possible leave headroom of one water heater height so the anode can be inspected or replaced. Remember you may have to remove the entire solar storage tank later for servicing.

It is recommended the solar storage tank be installed at ground or floor level and must stand vertically upright. The top of the solar storage tank must be a minimum of 500 mm below the bottom of the solar collector for the system to operate correctly.

Note: It is important for the solar storage tank to be orientated vertically upright in order for the falling film of closed circuit fluid to operate efficiently.

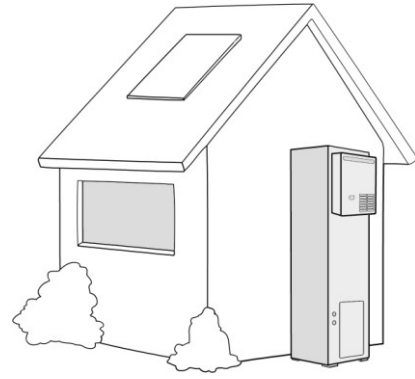

The water heater must not be installed in an area with a corrosive atmosphere where chemicals are stored or where aerosol propellants are released. Remember the air may be safe to breathe, but when it goes through a flame, chemical changes take place which may attack the water heater.

If an in-series gas booster is mounted to the solar storage tank, the water heater must not be installed indoors or in a confined space. A secondary flue is not required.

The water heater must be located to ensure that the location of the flue terminal complies with the requirements of AS 5601 or AS/NZS 5601.1, as applicable under local regulations. As a guide the following requirements are extracted from the Gas Installations Standard. The distances are measured along the wall behind the water heater.

- At least 300 mm between the top of the flue terminal and the eaves.
- At least 300 mm (20 litre models) or 500 mm (27 litre models) between the flue terminal and the edge of any opening into the building, such as an openable door or window, measured horizontally*.
- At least 1500 mm between the top of the flue terminal and the edge of any opening into the building, such as an openable window, measured vertically.
- At least 300 mm between the flue terminal and a return wall or external corner, measured horizontally*.
- At least 1500 mm between the flue terminal and any opening into a building, in the direction of the flue discharge.
- At least 500 mm between the flue terminal and a fence, wall or other obstruction, in the direction of the flue discharge.

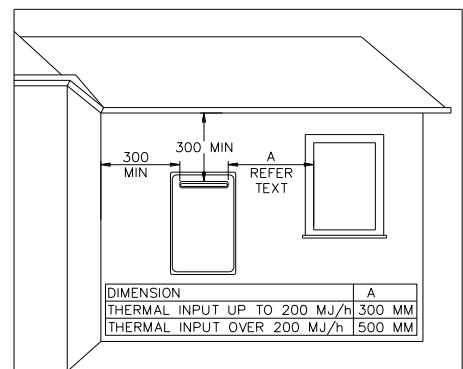
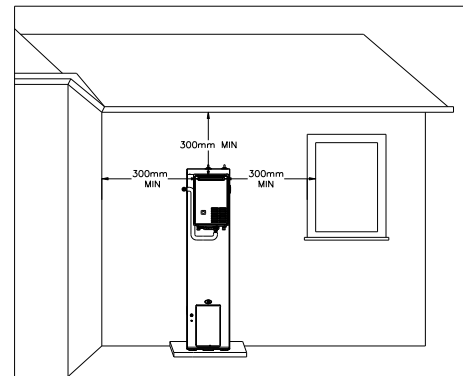

Note: * If these horizontal distances cannot be achieved, AS/NZS 5601.1 states an equivalent horizontal distance measured diagonally from the nearest discharge point of the flue terminal to the opening may be deemed to comply. Check with the local regulator.

SAFE TRAY

Where damage to property can occur in the event of the water heater leaking, the water heater must be installed in a safe tray. Construction, installation and draining of a safe tray must comply with AS/NZS 3500.4 and all local codes and regulatory authority requirements.

MAINS WATER SUPPLY

Where the mains water supply pressure exceeds that shown in the table below, an approved pressure limiting valve is required and should be fitted as shown in the installation diagram (refer to diagram on page 38).

Model	160
Relief valve setting	1000 kPa
Expansion control valve setting *	850 kPa
Max. mains supply pressure	
With expansion control valve	680 kPa
Without expansion control valve	800 kPa
Min. mains supply pressure **	140 kPa

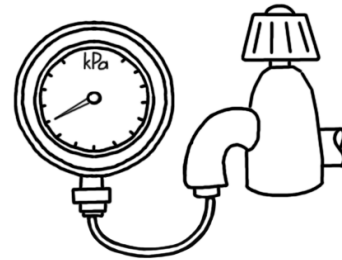

* Expansion control valve not supplied with the water heater.

** In-series gas booster only – solar storage tank has no minimum mains supply pressure requirements.

TANK WATER SUPPLY

If the water heater is supplied with water from a tank supply and a minimum water supply pressure of 140 kPa at the water heater cannot be achieved, then a pressure pump system must be installed to allow the in-series gas booster to achieve its rated flow and performance. Care must be taken to avoid air locks. The cold water line from the supply tank should be adequately sized and fitted with a full flow gate valve or ball valve. Consideration must be given to any minimum water supply requirements of another type of in-series booster water heater.

Notes:

- It is not recommended to install the in-series gas booster with a low pressure water supply.
- If sludge or foreign matter is present in the water supply, it is recommended a suitable filter be incorporated in the cold water line to the water heater.
- The in-series gas booster is not suitable for connection to bore water or spring water unless a water treatment device is fitted.
- Refer to “Water Supplies” on page 14 for further information on water chemistry.

RAIN WATER TANK

If the solar collector and solar pipe work are to be installed on a section of roof which is part of a rain water runoff collection system, then it is recommended this section of roof and its gutter be isolated from the rain water collection system. The gutter should be isolated to a width greater than the solar collector and pipe work and must have suitable drainage. The installer should ensure in the event of a leak from the solar collector or pipe work, a rainwater tank cannot be contaminated with closed circuit fluid.

The section of roof and gutter should be isolated from the rainwater collection system before the commissioning of the solar water heater, so that any leak or spillage during commissioning does not make its way into the rainwater tank.

This section of roof and guttering can be isolated by either:

- blocking this section of gutter from the remaining gutter and fitting two separate down pipes, one to take any run-off water from that section of roof away to drain and the other to the rainwater collection side of the gutter to take the rain water runoff to the rain water tank.
- blocking this section of gutter from the remaining gutter and fitting a tube or pipe of a material compatible with the gutter material in this section of the gutter and penetrating the separation pieces at either end to allow rainwater runoff to pass from one part of the rainwater collection system to the other. It may be necessary to fit a down pipe to the section of blocked gutter to take any run-off water from that section of roof away to drain.
- installing a false gutter inside of the existing gutter, with a down pipe penetrating the existing gutter to take any run-off water from that section of roof away to drain. The false gutter should be no deeper than half of the depth of the existing gutter, so as to enable rain water runoff to flow under the false gutter.
- installing a flashing from the underside of the roofing material, with a continuous fall, to over the outside lip of the gutter. The flashing should extend wider than the collector and pipe work and turned up at the ends so if there is leakage of closed circuit fluid, it cannot enter the gutter.

If any of these solutions are not practical, then the installer should discuss alternative options to suit the installation with the house holder.

Any alterations to the roof drainage system must comply with the relevant building regulations, codes and Standards.

FREEZE PROTECTION

The water heater has a freeze protection system. The water heater is not suitable for installation in areas where the ambient temperature falls below -20°C (including wind chill factor).

The solar circuit must be installed with a continuous fall of a minimum 5° (1 in 10 grade) in the pipe work from the solar collector to the solar storage tank, with the full length of the solar hot and solar cold pipes insulated and the system charged with correctly mixed closed circuit fluid to offer protection against freeze damage. The system has NO WARRANTY for freeze damage if there is not a continuous fall in the solar hot and solar cold pipes or they are not insulated in accordance with the installation instructions or the closed circuit fluid has been incorrectly mixed (refer to [“Terms of the Vulcan Warranty”](#) on page 63 and to [“Warning: Plumber Be Aware”](#) on page 35).

The solar collector and solar cold and solar hot pipes only contain closed circuit fluid when the pump is operating during periods of solar gain when heating is required. When the solar pump stops operating, the closed circuit fluid drains back into the storage tank heat exchanger. The closed circuit fluid is an anti-freeze agent which, when mixed to the correct specification, can withstand temperatures of -20°C before it may freeze.

The frost protection system to the in-series gas booster will protect the gas booster from damage, by preventing ice forming in the waterways of the gas booster, in the event of freezing conditions occurring. The frost protection system will be rendered inoperable if electrical power is not available at the in-series gas booster. Damage to the in-series gas booster caused by freezing of the pipe work to or from the gas booster is not covered under the Vulcan warranty. Refer to AS/NZS 3500.4 for precautions to be taken for installations in frost prone areas.

HOT WATER DELIVERY

This water heater can deliver water at temperatures which can cause scalding.

It is necessary and we recommend that a temperature limiting device be fitted between the water heater and the hot water outlets in any ablution area such as a bathroom or ensuite, to reduce the risk of scalding. The installing plumber may have a legal obligation to ensure the installation of this water heater meets the delivery water temperature requirements of AS/NZS 3500.4 so that scalding water temperatures are not delivered to a bathroom, ensuite or other ablution area.

The temperature limiting device used with a solar water heater should have a specified ‘minimum temperature differential’ between the hot water inlet and the tempered water outlet of no greater than 10°C. In addition, the temperature limiting device used with a continuous flow water heater should have a specified ‘maximum permitted pressure variation’ in either supply between the hot water inlet and the cold water inlet of no less than 15%. Refer to the specifications of the temperature limiting device.

Where a temperature limiting device is installed adjacent to the indirect solar water heater, the cold water line to the temperature limiting device can be branched off the cold water line either before or after the isolation valve, pressure limiting valve and non return valve to the solar storage tank. If an expansion control valve is required, it must always be installed after the non return valve and be the last valve prior to the solar storage tank.

If a pressure limiting valve is installed on the cold water line to the solar storage tank and the cold water line to a temperature limiting device branches off before this valve or from another cold water line in the premises, then a pressure limiting valve of an equal pressure setting may be required prior to the temperature limiting device.

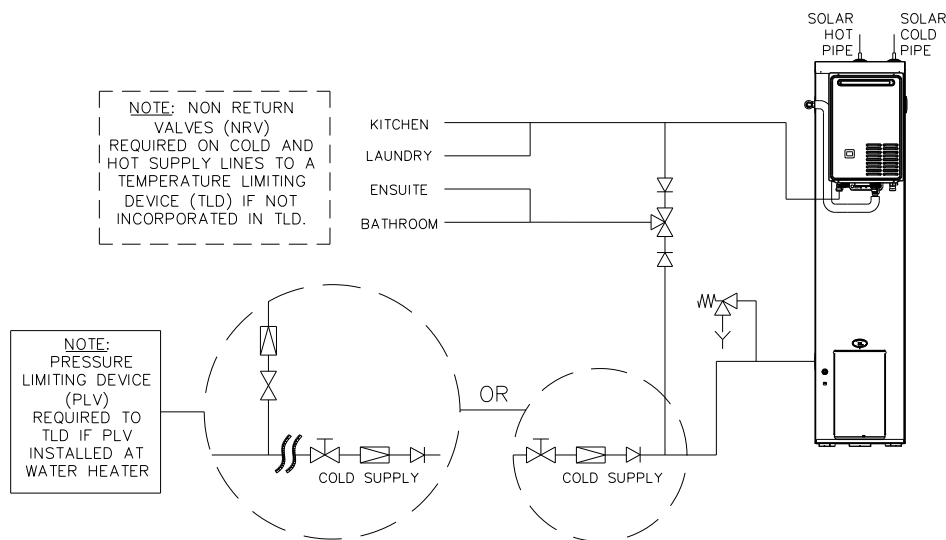

Two Temperature Zones – In-series Gas Booster Mounted on Storage Tank

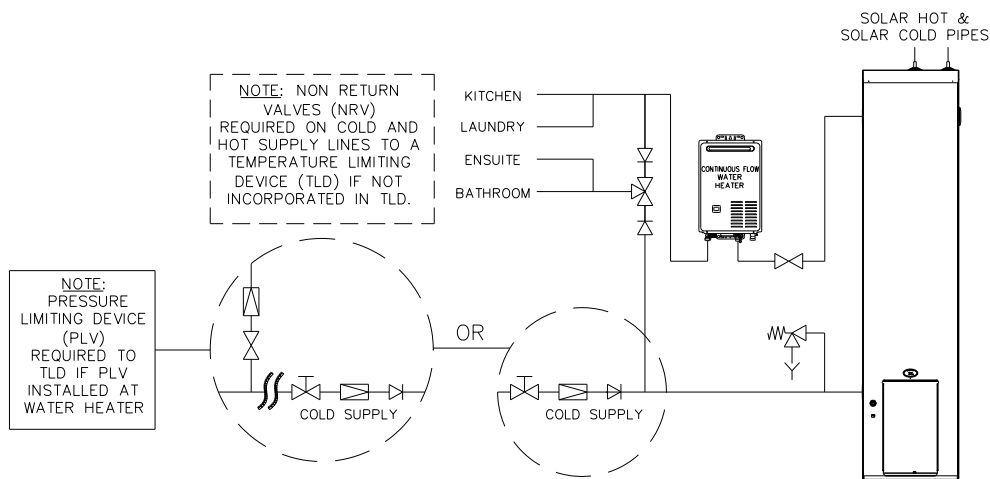

Two Temperature Zones – In-series Gas Booster Remote of Storage Tank

CIRCULATED HOT WATER FLOW AND RETURN SYSTEM

Remote Gas Booster

The solar storage tank of a solar water heater should not be installed as part of a circulated hot water flow and return system in a building. The benefits of solar gain will be significantly reduced and energy gained from the sun lost through the pipe work.

If a circulated flow and return system is required, it is necessary to connect the return line after the solar storage tank and prior to the in-series water heater supplied from the solar water heater. It is recommended to install the in-series gas booster remotely from the solar storage tank.

A remotely installed Vulcan 244 series continuous flow water heater can be installed as part of a circulated hot water flow and return system in a building.

If the in-series water heater is a continuous flow water heater, its preset outlet temperature setting must be set to at least 60°C or to meet the requirement of AS 3498, its setting must be set to at least 70°C.

If the in-series water heater is a storage water heater, its thermostat must always be set to at least 60°C.

Notes:

- Water should not be circulated from a water heater with a temperature setting of less than 60°C.

If the in-series booster is a continuous flow water heater, then the circulator must be:

- sized and set to provide a minimum flow rate of 3.0 L/min through the circulated hot water flow and return system, and
- either thermostatically and / or timer controlled.

The circulator **must not** be set to operate continuously, i.e. 24 hours per day.

Temperature Limiting Device

A temperature limiting device cannot be installed in circulated hot water flow and return pipe work. The tempered water supplied from the tempered hot water outlet on this water heater or from another temperature limiting device cannot be circulated.

Where a circulated hot water flow and return system is required in a building, a temperature limiting device can only be installed on a dead leg, branching off the circulated hot water flow and return pipe or a dead leg installed from the tempered water outlet of this water heater.

If circulated tempered water were to be returned back to the water heater, depending on the location of the return line connection on the water supply line to the water heater, then either:

- water will be supplied to the cold water inlet of the temperature limiting device at a temperature exceeding the maximum recommended water supply temperature, or
- when the hot taps are closed no water will be supplied to the cold water inlet of the temperature limiting device whilst hot water will continue to be supplied to the hot water inlet of the temperature limiting device.

These conditions may result in either water at a temperature exceeding the requirements of AS/NZS 3500.4 being delivered to the hot water outlets in the ablution areas, or the device closing completely and not delivering water at all, or the device failing. Under either condition, the operation and performance of the device cannot be guaranteed.

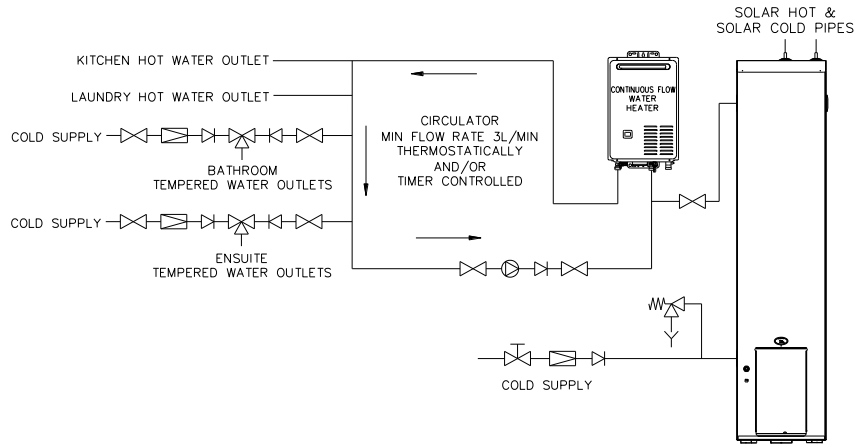

NOTE: A PLV IS REQUIRED TO BE INSTALLED ON THE COLD SUPPLY LINE TO THE TEMPERING VALVE IF A PLV IS INSTALLED ON THE COLD SUPPLY LINE TO THE WATER HEATER.
NON RETURN VALVES (NRV) REQUIRED ON COLD AND HOT SUPPLY LINES TO A TEMPERATURE LIMITING DEVICE (TLD) IF NOT INCORPORATED INTO TLD.

**Circulated Hot Water Flow and Return System
In-series Gas Booster Remote of Storage Tank**

REDUCING HEAT LOSSES

The cold water line to and the hot water line from the water heater must be insulated in accordance with the requirements of AS/NZS 3500.4. The insulation must be weatherproof and UV resistant if exposed.

The full length of the solar hot and solar cold pipes between the solar storage tank and the solar collector(s) **MUST BE** insulated. Refer to “Warning: Plumber Be Aware” on page 35.

ANODE

The vitreous enamel lined cylinder of the water heater is only covered by the Vulcan warranty when the total dissolved solids (TDS) content in the water is less than 2500 mg/L and when the correct colour coded anode is used. If an incorrect colour coded anode is used in the water heater, any resultant faults will not be covered by the Vulcan warranty. In addition, the use of an incorrect colour coded anode may shorten the life of the water heater cylinder.

The correct colour coded anode for the water supply being used must be selected and fitted to the water heater for the Vulcan warranty to apply to the water heater cylinder (refer to “Water Supplies” on page 14 and the Anode Selection chart on page 14). The black anode is typically fitted as standard.

Total Dissolved Solids	Anode colour code
0 – 40 mg/L	Green
40 – 150 mg/L	Green or Black
150 – 400 mg/L	Black
400 – 600 mg/L	Black or Blue
600 – 2500 mg/L	Blue
2500 mg/L +	Blue (no cylinder warranty)

If the water supply has a TDS greater than 150 mg/L and a green anode has not been changed to a black anode, or if the TDS is greater than 600 mg/L and the anode has not been changed to a blue anode, there is the possibility the anode may become overactive and hydrogen gas could accumulate in the top of the water heater during long periods of no use. In areas where this is likely to occur, the installer should instruct the householder on how to dissipate the gas safely (refer to “Caution” on page 15).

SADDLING - PIPE WORK

To prevent damage to the cylinder when attaching pipe clips or saddles to the water heater jacket, we recommend the use of self-drilling screws with a maximum length of 13 mm. Should pre drilling be required, extreme caution must be observed when penetrating the jacket of the water heater.

Note: If the cylinder is damaged as a result of attaching pipe clips or saddles to the jacket, any resultant faults will not be covered by the Vulcan warranty.

DIMENSIONS AND TECHNICAL DATA

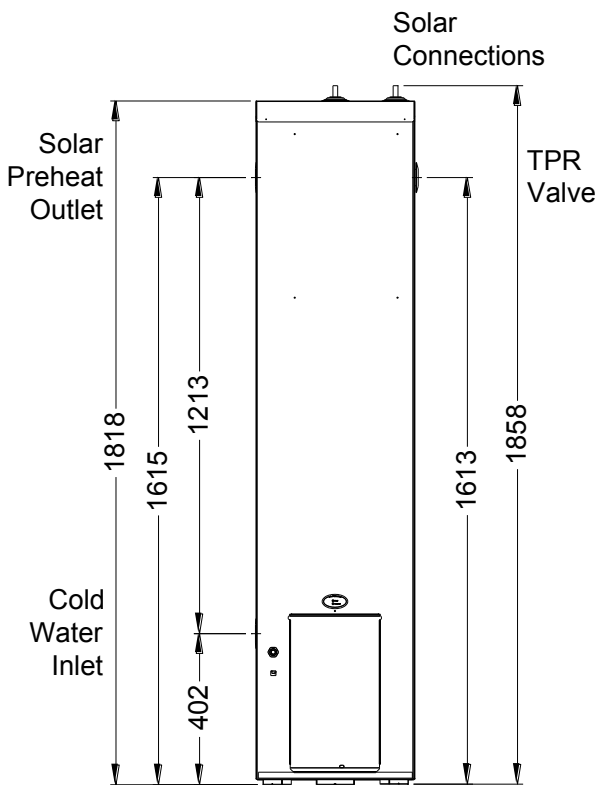
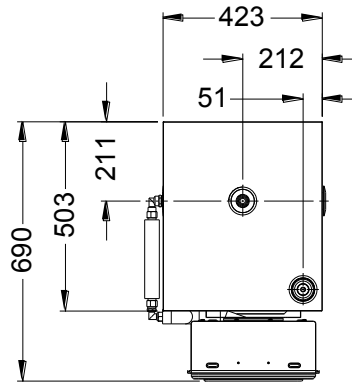
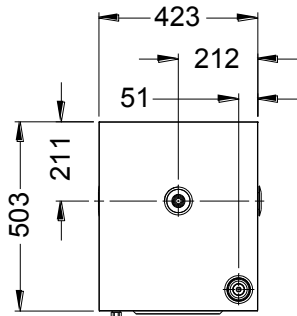

storage tank with remote boost

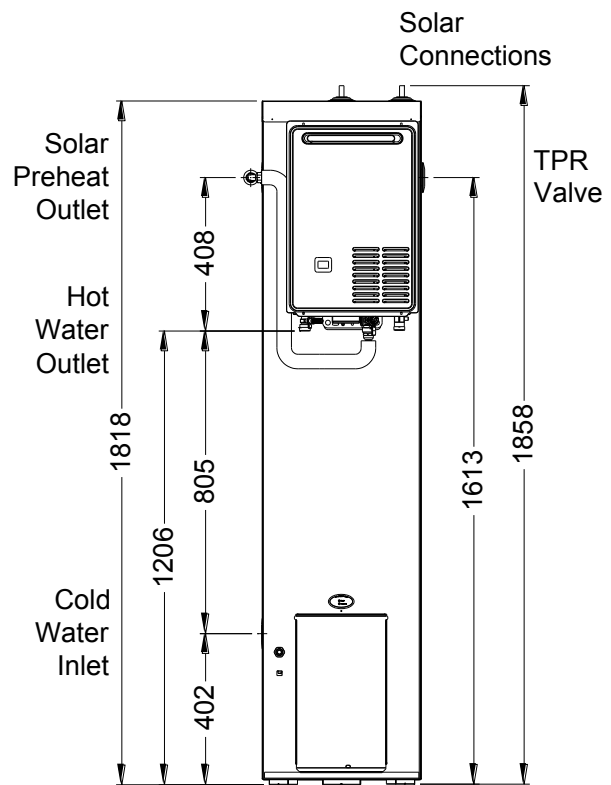

storage tank with tank mounted in-series gas booster

Model	690 160	Capacity	160 litres	Mass	98 kg (empty)	258 kg (full)
--------------	---------	-----------------	------------	-------------	---------------	---------------

The storage tank model number ends in a '00', e.g. 690 160 00, as it has no integrated gas or electric boosting.

IP rating = 24

Gas Booster Details	Gas Booster Model	Recovery @ 25°C rise (litres / min)	Hourly Gas Consumption (MJ)	Min. Gas Pressure (kPa)	Test Point Gas Pressure (kPa)		Max. Gas Pressure (kPa)
					minimum	maximum	
Natural	241 027 NF	27	205	1.13	0.193	0.905	3.50
Propane	241 027 PF	27	205	2.75	0.277	1.430	3.50
Natural	244 020 NF	20	153	1.13	0.170	0.870	3.50
Propane	244 020 PF	20	153	2.75	0.190	1.185	3.50

Model numbers: N = Natural, P = Propane.

Letter N or P is included in the model number of the gas booster, e.g. 244 020 NF, to denote gas type.

F = Frost protection.

Technical data is subject to change.

TYPICAL INSTALLATION – TANK MOUNTED GAS BOOSTER 20L

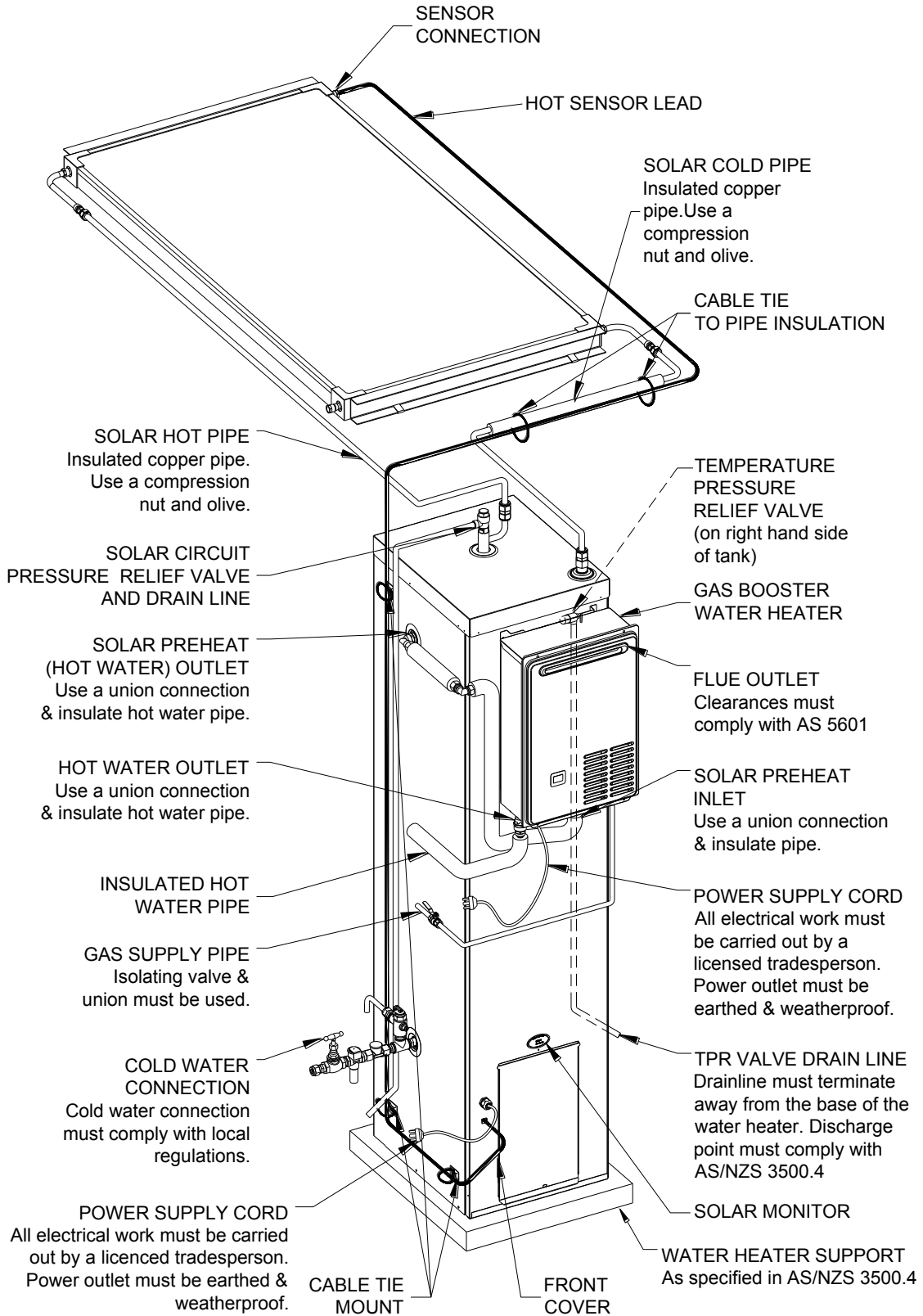

Solar VSi Indirect (Outdoor Tank Location) Water Heater with Tank Mounted In-Series 20L Gas Booster

TYPICAL INSTALLATION – REMOTE GAS BOOSTER 20L

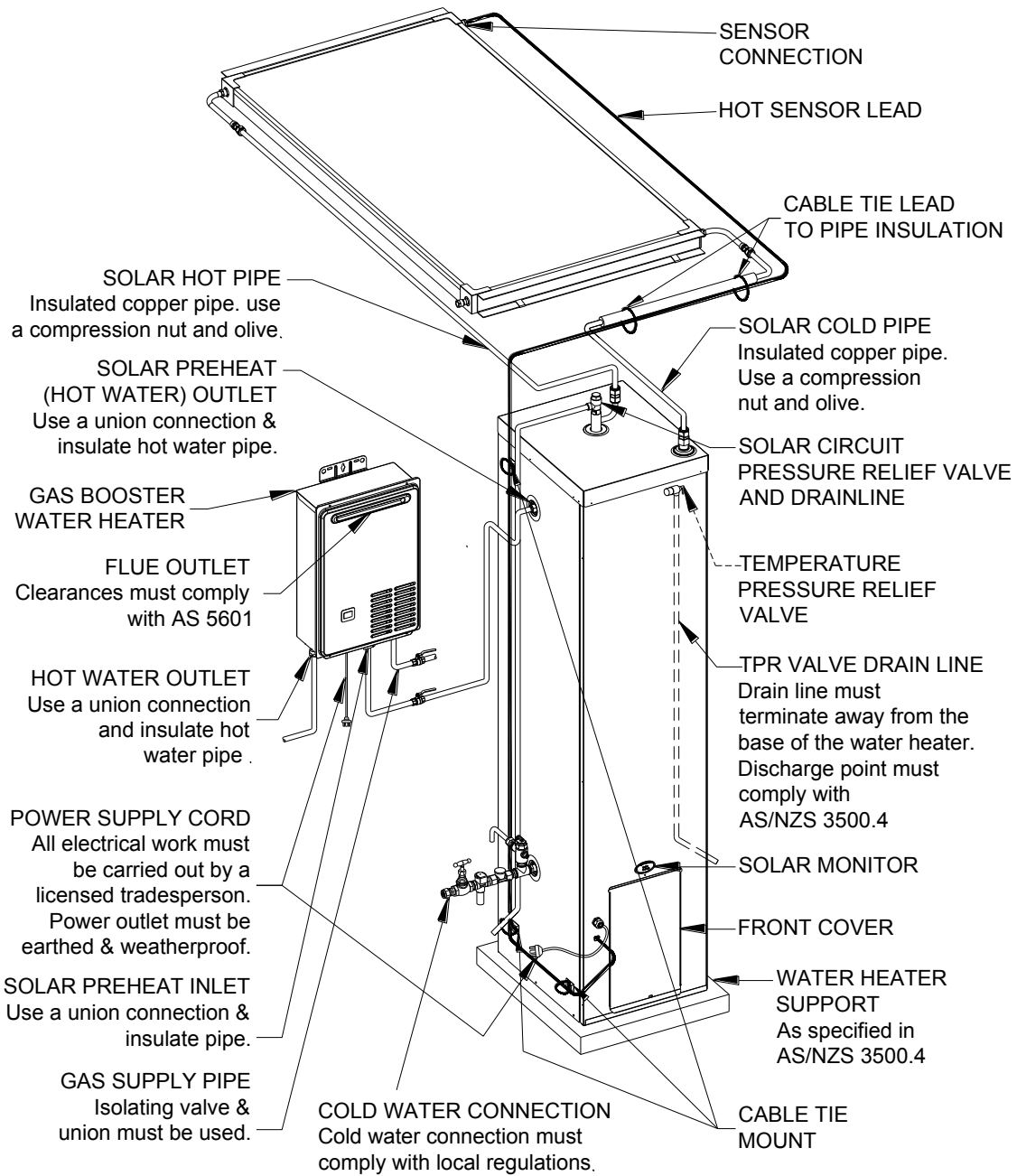

Solar VSi Indirect (Outdoor Tank Location) Water Heater with Remote In-Series 20L Gas Booster

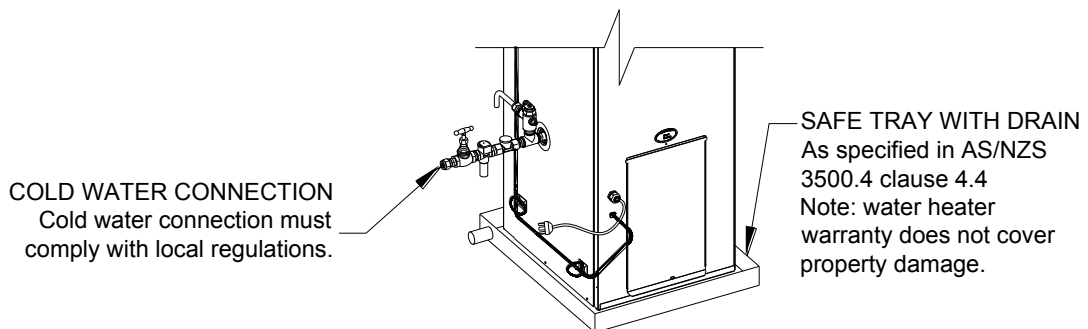

Solar VSi Indirect (Indoor Tank Location) Water Heater with Remote In-Series 20L Gas Booster

TYPICAL INSTALLATION – REMOTE GAS BOOSTER 27L

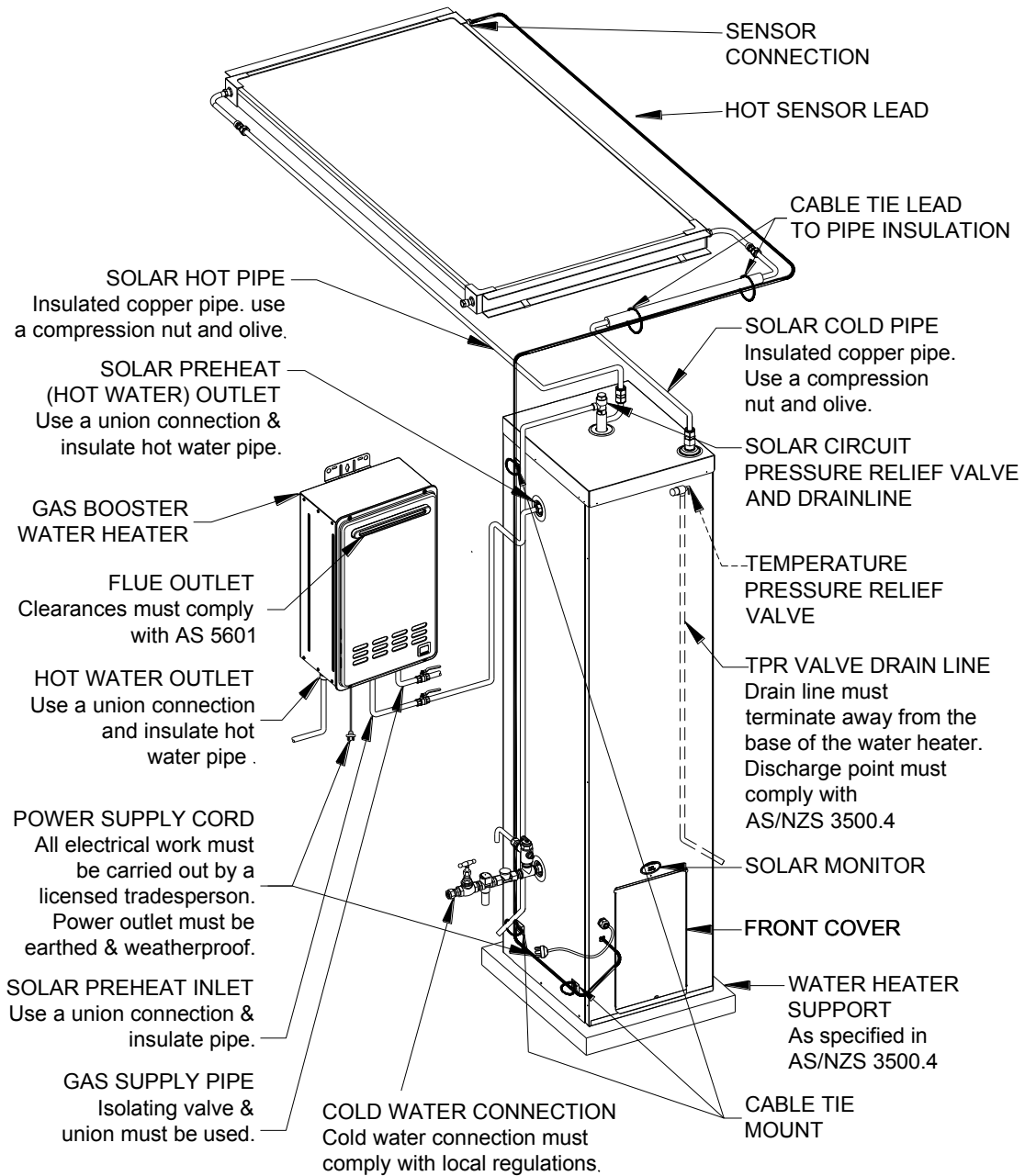

Solar VSi Indirect (Outdoor Tank Location) Water Heater With Remote In-Series 27L Gas Booster

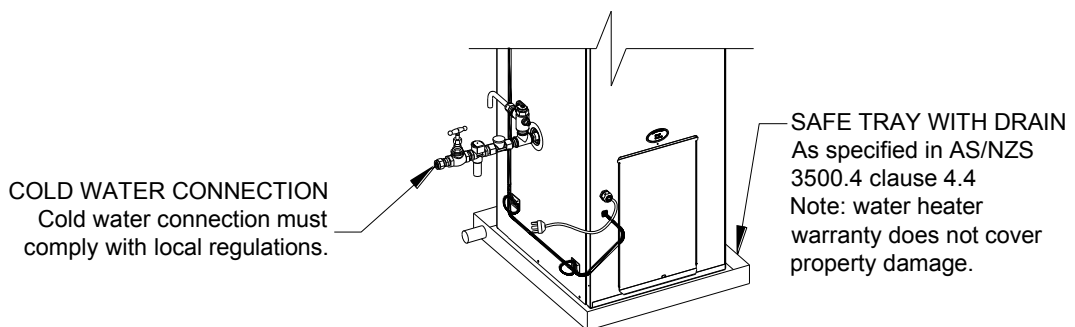

Solar VSi Indirect (Indoor Tank Location) Water Heater with Remote In-Series 27L Gas Booster

INSTALLATION – SOLAR COLLECTOR

SOLAR COLLECTOR LOCATION

Consideration must be given to the position of the solar collector in relation to the solar storage tank. There are limitations on both the maximum length of the solar hot and solar cold pipes and the maximum height between the solar storage tank and the solar collector. Refer to “Solar Storage Tank Location” on page 22 and to “Pipe Lengths” on page 34.

- The solar collector must be installed in a shade free position.
- The surrounding vicinity should be checked for higher buildings or trees which may cause shade at other times of the year and for small trees which may grow and shade the solar collectors in the future.

- For optimum performance, solar collectors should be installed facing towards the equator (i.e. north facing in the southern hemisphere and south facing in the northern hemisphere). ALWAYS CHECK ORIENTATION WITH A COMPASS. Where this orientation is not practical, solar collectors facing up to 45° from the equator will receive about 4% less total solar radiation.

- For optimum performance, inclination of the solar collectors should be approximately equal to 90% of the local latitude angle. The [latitudes of some Australian cities](#) are listed on page 34. The solar collector may be installed at the roof angle for simplicity of installation and appearance, but must never be less than 10°. If the roof angle varies by 15° from the optimum angle, the solar collectors will receive about 10% less total solar radiation.

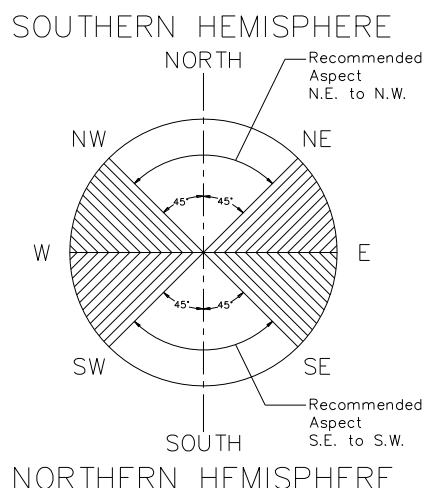

- The collector kit is suitable for installations with an inclination of up to 45°. Where the solar collector is installed at an inclination greater than 45°, a With Pitch frame is necessary. Refer to your local Solar Distributor for details.
- For an installation on a roof with a pitch less than 10°, a Variable Pitch frame is required. Refer to your local Solar Distributor for details.
- For an installation of a collector on a pitched roof in a cyclonic or high wind area, a suitable With Pitch frame is required. Refer to your local Solar Distributor for details.
- The installation of this solar collector on a suitable frame, subject to the frame's design criteria not being exceeded:
 - is suitable for installation in geographic locations up to and within Wind Region D (With Pitch frame) or up to and within Wind Region C (Variable Pitch frame), as defined in the Building Code of Australia, Australian / New Zealand Standard AS/NZS 1170.2:2002 and the Australian Standard AS 4055-2006, and
 - provides an acceptable method of installation where it is necessary to satisfy the requirements of the Building Code of Australia and AS/NZS 3500.4 Clause 6.5.3.4 for high wind areas.
- The installer must ensure the structural integrity of the building is not compromised by the solar water heater installation and the roof structure is suitable to carry the full weight of the solar collector(s). If in doubt the roof structure should be suitably strengthened. Consult a structural engineer.
- Each solar collector and its fittings weighs approximately 54 kg when full of water.
- The installation must comply with the requirements of AS/NZS 3500.4 and all local codes and regulatory authority requirements.
- Refer to the installation instructions supplied with the collector kit for details on the installation of the solar collector.

LATITUDE OF SOME AUSTRALIAN CITIES

Adelaide	35°S	Cairns	17°S	Hobart	42°S	Port Hedland	20°S
Alice Springs	24°S	Canberra	35°S	Mildura	34°S	Rockhampton	24°S
Brisbane	27°S	Darwin	12°S	Melbourne	38°S	Sydney	34°S
Broken Hill	31°S	Geraldton	28°S	Perth	32°S	Townsville	19°S

PIPE LENGTHS

The solar hot and solar cold pipes between the solar storage tank and the solar collector shall:

- be of DN15 bendable grade or hard drawn copper tube.
Annealed or soft copper shall not be used.
- have a continuous fall from the solar collector to the solar storage tank of a minimum 5° (1 in 10 grade).
- not exceed the maximum recommended length as specified in the table.

Maximum recommended total combined pipe length (solar cold + solar hot) and number of 90° bends		
Pipe Size	1 or 2 Collectors	
	Pipe Length	90° Bends
DN15	30 metres	15

For each additional 90° bend, reduce the maximum total pipe length by 0.5 metres.

For each additional metre of pipe length, reduce the number of 90° bends by two.

Note: One 90° elbow is equal to two 90° bends.

Notes:

- It is important not to cross connect the solar cold and solar hot pipes to the incorrect connections at the solar collector and at the solar storage tank.
- The solar cold pipe connects to the bottom of the solar collector and the solar hot pipe connects to the top of the solar collector diagonally opposite to the solar cold pipe connection.

The lowest corner of the solar collector installation, which is where the solar cold pipe connects to the collector array, should be the corner closest to the solar storage tank. This will maximise the gradient for the continuous fall of the solar cold pipe, by providing a shorter horizontal run of pipe work for the vertical fall.

- The hot sensor connection is at the top of the solar collector, directly above the solar cold inlet connection.
- Refer to [“Warning: Plumber – Be Aware”](#) on page 35.

It is essential for these requirements to be followed for the system to operate correctly and efficiently. Solar pipe work which is oversized, or does not have the correct fall, or is too long can result in the drain back system not operating effectively.



WARNING: Plumber – Be Aware

- The solar hot and solar cold pipes between the solar storage tank and the solar collectors **MUST BE** of copper. All compression fittings must use brass or copper olives.
- The full length of the solar hot and solar cold pipes **MUST BE** insulated.

The insulation must:

- be of a closed cell type or equivalent, suitable for a solar water heating application and capable of withstanding the temperature of the closed circuit fluid generated by the solar collectors under stagnation conditions

The specification of the chosen insulation material should be checked with the insulation manufacturer prior to installation as different materials may vary in temperature tolerance.

- be at least 13 mm thick, however thicker insulation may be required to comply with the requirements of AS/NZS 3500.4
- be weatherproof and UV resistant if exposed
- extend through any penetrations in the eaves, ceiling and roof
- cover valves and fittings in the solar hot and solar cold pipe work
- be fitted up to and cover the connections on both the solar storage tank and the solar collectors.

The insulation will offer corrosion protection to a metal roof against water runoff over the copper pipe, assist in avoiding accidental contact with the solar pipe work as high temperature closed circuit fluid can flow from the solar collectors to the solar storage tank and also reduce pipe heat losses.

- There **must be a continuous fall** of a minimum 5° (1 in 10 grade) in the pipe work between the solar collector and solar storage tank for efficient and effective drain back to occur. The highest point of the solar cold pipe and solar hot pipe must be where they connect to the solar collector.

The system has NO WARRANTY for freeze damage if there is not a continuous fall in the solar hot and solar cold pipes, or they are not insulated in accordance with the installation instructions, or the closed circuit fluid has been incorrectly mixed.

- The insulated copper pipe work:
 - should be fixed at suitable locations to prevent or reduce the possibility of noise from water hammer and vibration from occurring
 - is not to be placed or installed in contact with plastic pipe work.

Likewise, plastic pipe work is not to be placed or installed in contact with the insulated copper pipe work after the solar circuit is installed.

- Plastic pipe **MUST NOT** be used, as it will not withstand the temperature of the closed circuit fluid generated by the solar collector under stagnation conditions. The solar collector can generate extremely high closed circuit fluid temperatures up to 150°C. Plastic pipe cannot withstand these temperatures and **MUST NOT** be used. Failure of plastic pipe can lead to the release of high temperature closed circuit fluid and cause severe water damage and flooding.
- The pressure applied to the solar circuit and solar collector during a pressure test of an indirect closed circuit system **MUST NOT** exceed 200 kPa, otherwise damage may result to the solar collector. Refer to “[Pressure Testing](#)” on page 37.

Maximum Height To Collector

The solar collector must be the highest point of the system. The maximum height of the solar installation, from the base of the solar storage tank to the top of the solar collector, is 7.5 m. The pump supplied with the solar storage tank will not circulate closed circuit fluid through heights greater than 7.5 m and solar gain will not be achieved.

An additional or auxiliary pump cannot be added to this system, nor can the pump supplied with the system be replaced with another pump, to increase the maximum height of the system.

Note: The top of the solar storage tank must be a minimum of 500 mm below the bottom of the solar collector for the system to operate correctly.

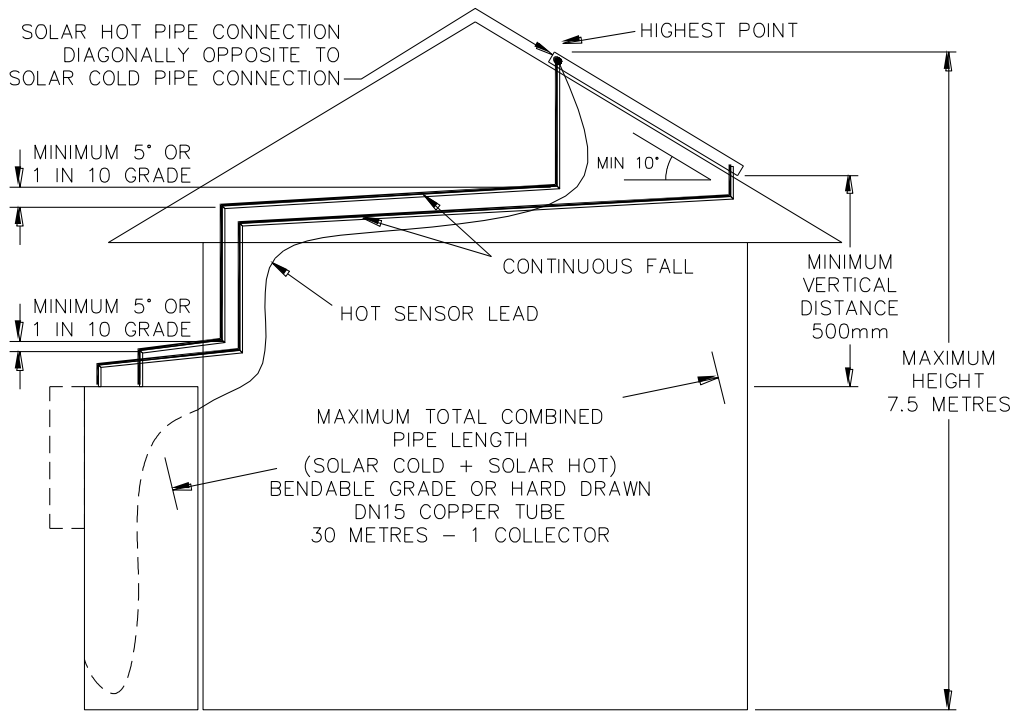

NOTES:

- PIPE WORK MUST HAVE A CONTINUOUS FALL OF NOT LESS THAN 5° (1 IN 10 GRADE).
- PIPE WORK MUST BE OF BENDABLE GRADE OR HARD DRAWN DN15 COPPER TUBE. ANNEALED OR SOFT COPPER SHALL NOT BE USED.
- THE LOWEST CORNER OF THE SOLAR COLLECTOR INSTALLATION (SOLAR COLD CONNECTION) SHOULD BE THE CORNER CLOSEST TO THE SOLAR STORAGE TANK.
- INSTALL HOT SENSOR LEAD WITH INSULATED SOLAR PIPES DURING CONSTRUCTION FOR NEW HOMES.
- PRESSURE TESTING OF SOLAR COLLECTOR AND SOLAR CIRCUIT MUST NOT EXCEED 200KPa.

Indirect Drain Back Solar Pipe Work Installation Requirements

Pressure Testing

The solar water heater, including the collector circuit and solar collectors, is to be isolated during the testing and commissioning of the heated water reticulation system in a building, in accordance with Clause 11.1 and 11.3 (a) of AS/NZS 3500.4.

It may be necessary to pressure test the collector circuit to comply with codes and regulatory authority requirements or on other occasions where the solar collectors and solar cold and solar hot pipe work are installed prior to the solar storage tank, such as on a building site.

Indirect Closed Collector Circuit

⚠ Warning: The pressure applied to the solar circuit and solar collectors during a pressure test of an indirect closed circuit system **MUST NOT** exceed 200 kPa, otherwise damage may result to the solar collectors. The solar circuit and solar collectors are to be isolated from the solar storage tank for the duration of the pressure test.

T200 Solar Collector Installation

If water is used as the pressure testing medium and if the collector circuit is not to be connected to the solar storage tank and the system commissioned on the same day, then any excess moisture needs to be blown out and the collector circuit and solar collectors dried using dry compressed air.

It is necessary to cap off the ends of the solar cold and solar hot pipes if they are not connected to the solar storage tank at the time of installation and at the time of testing the solar circuit. It is not necessary to cap off the ends of the solar cold and solar hot pipes if NPT200 collectors are installed.

Indirect Closed System

If the solar collectors, solar pipe work and solar storage tank are installed and commissioned together, then the flooding of the collector circuit with closed circuit fluid for an indirect closed circuit system or water under mains pressure for a direct open circuit system and checking for the pipe work for leaks during the commissioning procedure can be substituted for the pressure testing of the collector circuit.

CONNECTIONS – PLUMBING

All plumbing work must be carried out by a qualified person and in accordance with the requirements of the Standard AS/NZS 3500.4, and all local codes and regulatory authority requirements. In New Zealand, the installation must conform with Clause G12 of the New Zealand Building Code.

All gas work must be carried out by a qualified person and in compliance with the Standard AS 5601 or AS/NZS 5601.1, as applicable under local regulations, and all local codes and regulatory authority requirements. In New Zealand the installation must also conform with NZS 5261, as applicable under local regulations.

Note: The solar storage tank of a solar water heater should not be installed as part of a circulated hot water flow and return system in a building. The benefits of solar gain will be significantly reduced and energy gained from the sun lost through the pipe work. If a circulated flow and return system is required, it is necessary to connect the return line after the solar storage tank and prior to the in-series water heater supplied from the solar water heater. Refer to “[Circulated Hot Water Flow and Return System](#)” on page 27.

CONNECTION SIZES

- Hot water connection to in-series gas booster: R $\frac{3}{4}$ /20.
- Solar heated water connection to in-series gas booster: R $\frac{3}{4}$ /20.
- Solar heated water connection to solar storage tank: RP $\frac{3}{4}$ /20.
- Cold water connection: RP $\frac{3}{4}$ /20.
- Solar hot (from collector) connection: DN15 compression fitting.
- Solar cold (to collector) connection: DN15 compression fitting.
- Temperature Pressure Relief valve connection: RP $\frac{1}{2}$ /15.
- Solar circuit pressure relief valve connection: R $\frac{1}{2}$ /15.
- Gas connection: R $\frac{3}{4}$ /20.

WATER INLET AND OUTLETS

All pipe work must be cleared of foreign matter before connection and purged before attempting to operate the water heater. All olive compression fittings must use brass or copper olives. Use thread sealing tape or approved thread sealant on all fittings.

An isolation valve and non return valve must be installed on the cold water line to the water heater. An acceptable arrangement is shown in the diagram. Refer also to “[Hot Water Delivery](#)” on page 26 and to “[Mains Water Supply](#)” on page 24.

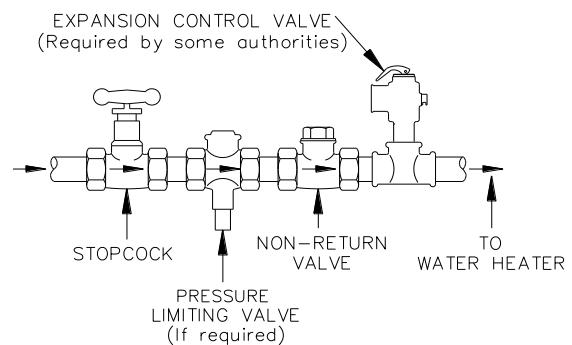

A disconnection union must always be provided at the cold water inlet and hot water outlet on the water heater to allow for disconnection of the water heater.

The plumbing arrangements for the solar heated water outlet of the solar storage tank and the water inlet of a tank mounted in-series gas booster are shown on page 39. The solar hot and solar cold pipe connections are shown on page 42.

This solar storage tank has either a plastic dip tube or fitting liner in the inlet and outlet fittings (see diagram). These must be in place for the water heater to function properly. Do not remove or damage them by using heat nearby. They will be pushed into the correct position as the fitting is screwed in.

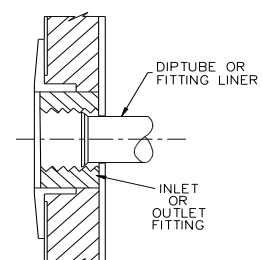

PIPE SIZES

To achieve true mains pressure operation, the cold water line to the water heater should be the same size or bigger than the hot water line from the water heater. The minimum recommended hot pipe size is DN20.

The pipe sizing for hot water supply systems should be carried out by persons competent to do so, choosing the most suitable pipe size for each individual application. Reference to the technical specifications of the water heater and local regulatory authority requirements must be made.

IN-SERIES BOOSTER – INTEGRATED

An insulated DN15 preformed copper pipe and braided flexible hose assembly is supplied for connecting between the solar heated water outlet and a Vulcan 244 020 model in-series gas booster mounted onto the solar storage tank.

⚠ Warning: A 027 model in-series gas booster cannot be mounted on the solar storage tank and may only be installed remotely. The size and weight of the in-series gas booster may cause the solar storage tank to topple over.

Notes:

- Use thread sealing tape or an approved thread sealant on all fittings.
- Numbers in parentheses refer to items on diagram on page 39.

To mount the in-series gas booster to the solar storage tank:

- Position the mounting bracket (7) at the top of the front panel of the storage tank and secure with the four screws (8) provided.
- Remove the mounting bolt (9) from the centre bottom of the backing plate.
- Remove the screws securing the top bracket at the rear of the in-series gas booster, rotate the bracket through 180° and refit the screws.
- Fit the in-series gas booster to the mounting bracket by hooking the top bracket of the gas booster over the mounting bracket.
- Fix the in-series gas booster to the centre bottom of the mounting bracket using the mounting bolt (9) provided.

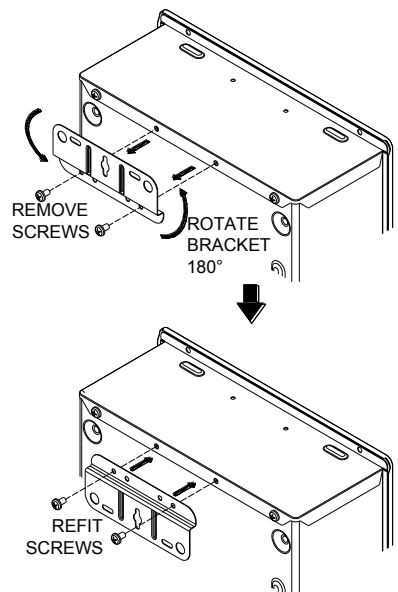

repositioning top bracket on gas booster

To connect the preformed copper pipe to the solar storage tank and in-series gas booster:

- Fit the 3/4" x 1/2" hex nipple (1) to the solar heated water outlet of the solar storage tank.
- Fit the 1/2" F x 1/2" M elbow (2) to the hex nipple at the solar heated water outlet of the solar storage tank.
- Fit one end of the 1/2" x 1/2" female cone braided flexible hose assembly (3) to the 1/2" F x 1/2" M elbow (2).
- Fit the 1/2" M x 1/2" C elbow fitting (4) to the other end of the braided flexible hose.
- Connect the short end of the insulated DN15 preformed pipe (5) to the 1/2" M x 1/2" C elbow (4) using the compression nut and olive provided with the elbow.
- Connect the other end of the DN15 preformed pipe to the inlet of the in-series gas booster using the 3/4" F x 1/2" C fitting union (6) and the compression nut and cone olive provided.

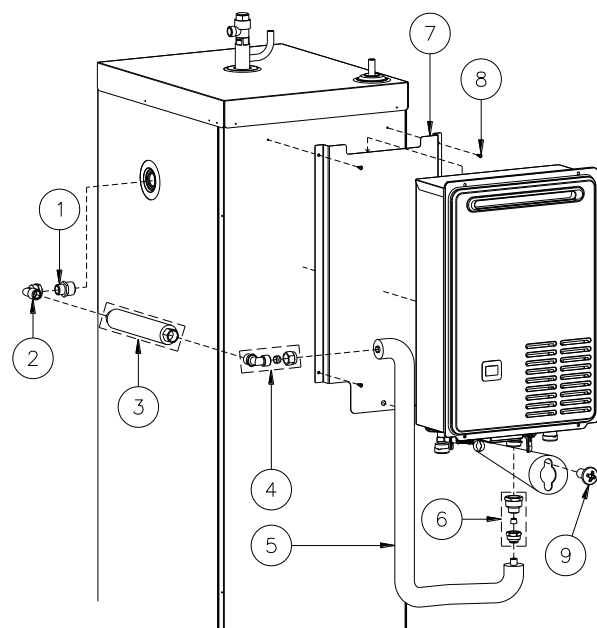

mounting gas booster to solar storage tank and connecting pipe work

RELIEF VALVE DRAIN

DN15 copper drain lines must be fitted to the temperature pressure relief valve, expansion control valve (if one is installed) and solar circuit relief valve to carry the discharge clear of the water heater. Connect the drain lines to the valves using disconnection unions. The drain line from the valve to the point of discharge should be as short as possible, have a continuous fall all the way from the water heater to the discharge outlet and have no tap, valves or other restrictions in the pipe work.

A drain line from a relief valve must comply with the requirements of AS/NZS 3500.4.

A drain line must be no longer than 9 metres with no more than three bends greater than 45° before discharging at an outlet or air break. The maximum length of 9 metres for a drain line is reduced by 1 metre for each additional bend required of greater than 45°, up to a maximum of three additional bends. Where the distance to the point of final discharge exceeds this length, the drain line can discharge into a tundish.

Subject to local regulatory authority approval, the drain lines from the temperature pressure relief valve and expansion control valve from an individual water heater may be interconnected.

The outlet of a drain line must be in such a position that flow out of the pipe can be easily seen, but arranged so discharge will not cause injury, damage or nuisance. The termination point of a drain line must comply with the requirements of AS/NZS 3500.4. Drain lines must not discharge into a safe tray.

In locations where water pipes are prone to freezing, drain lines must be insulated, must not exceed 300 mm in length and are to discharge into a tundish through an air gap of between 75 mm and 150 mm.

If a drain line discharges into a tundish, the drain line from the tundish must be not less than DN20. The drain line from a tundish must meet the same requirements as for a drain line from a relief valve.

⚠ Warning: As the function of the temperature pressure relief valve on this water heater is to discharge high temperature water under certain conditions, it is strongly recommended the pipe work downstream of the relief valve be capable of carrying water exceeding 93°C. Failure to observe this precaution may result in damage to pipe work and property.

SOLAR INLET AND OUTLET

All pipe work must be cleared of foreign matter before connection and purged before attempting to operate the water heater. All olive compression fittings must use brass or copper olives. Use thread sealing tape or approved thread sealant on all fittings.

The solar cold outlet and solar hot inlet connections are located at the top of the solar storage tank.

Notes:

- It is important not to cross connect the solar cold and solar hot pipes to the incorrect connections.
 - The solar cold pipe connects to the bottom of the solar collector and the solar hot pipe connects to the top of the solar collector on the opposite side to both the solar cold pipe connection and the hot sensor connection.
 - The solar hot inlet connection is located in the centre of the top of the solar storage tank (the connection is marked by a label on top of the storage tank).
 - The solar cold outlet connection is located at a corner of the top of the solar storage tank (the connection is marked by a label on top of the storage tank).
- Connect the solar pipes to the solar storage tank using only the fittings supplied.

To connect the solar cold and solar hot pipes to the solar storage tank:

Solar hot pipe connection

- Remove the plastic cap from the solar hot inlet pipe end at the top of the solar storage tank.
- Undo the compression nut and olive from the compression union and fit over the solar hot pipe connection.
- Fit the ½" x ½" nipple from the compression union supplied to the solar hot inlet pipe end.
- Connect the solar hot pipe (flow from the collector) to the ½" x ½" nipple using the compression nut and olive supplied.

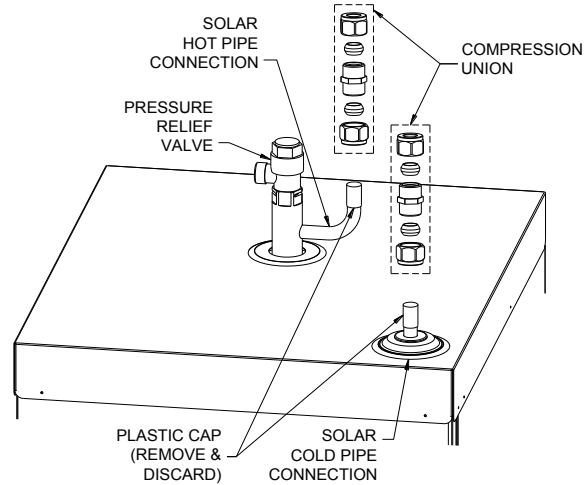

Solar cold pipe connection

- Remove the plastic cap from the solar cold outlet pipe end at the top of the solar storage tank.
- Undo the compression nut and olive from the compression union and fit over the solar cold pipe connection.
- Fit the ½" x ½" nipple from the compression union supplied to the solar cold outlet pipe end.
- Connect the solar cold pipe (flow to the collector) to the ½" x ½" nipple using the compression nut and olive supplied.

GAS INLET

The gas connection is made at the underside of the in-series gas booster. The pipe work must be cleared of foreign matter before connection and purged before attempting to operate the water heater. An isolation valve and disconnection union must be installed to allow servicing and removal of the water heater.

Note: Refer to the Gas Installations Standard AS 5601 or AS/NZS 5601.1 for the correct method of sizing the gas supply pipe to the water heater. The pipe size selection must take into account the high gas input of the in-series gas booster ([refer to table on page 29](#)) as well as all of the other gas appliances in the premises.

⚠ Warning: Always isolate the in-series gas booster before pressure testing the gas supply system. Disconnect the in-series gas booster after the isolating cock to prevent the risk of serious damage to the gas control. The Vulcan warranty does not cover damage of any nature resulting from failure to observe this precaution. Refer to rating label for gas types and pressures.

CONNECTIONS – ELECTRICAL

The power supply to the water heater must not be switched on until the solar storage tank is filled with water.

MEGGER READING

It is not mandatory to conduct a megger test on a plug in appliance, however if a megger test is conducted on this water heater, then the following should be noted.

⚠ Warning: This water heater contains electronic equipment and 500 V insulation tests must only be conducted between either active and earth or neutral and earth. An active to neutral test WILL damage the electronics.

An insulation test result of approximately 660 KΩ for this water heater is normal.

Typically the insulation resistance between live and earthed parts of an electrical installation should not be less than 1 MΩ. However AS/NZS 3000:2000 clause 6.3.3.3.2 'Results' states:

"The value of 1 MΩ may be reduced to:

- 0.01 MΩ for sheathed heating elements or appliances; or
- a value permitted in the Standard applicable to electrical equipment."

This model water heater is categorised as a 'stationary class 1 motor operated appliance' and has been tested to AS/NZS 3350.1:2002 clause 16 'Leakage current and electric strength' and has passed the requirements of this Standard. Therefore, this model water heater complies with the condition stated in AS/NZS 3000:2000 clause 6.3.3.3.2 (b).

ELECTRICAL CONNECTION

All electrical work and permanent wiring must be carried out by a qualified person and in accordance with the Wiring Rules AS/NZS 3000 and all local codes and regulatory authority requirements.

⚠ Warning: Temperature controllers **must not** be fitted to the in-series booster as part of a solar water heater system because water at a temperature much higher than the controller setting can be delivered.

The water heater requires a 240 V AC, 50 Hz mains power supply for operation. The solar storage tank and in-series gas booster are each supplied with a 1.8 metre power cord to operate the solar control unit and gas booster. Two switched general purpose outlets (GPO) are required to be located within 1.2 metres of the installation. The GPOs must have a continuous power supply. The GPOs are required to be weatherproof if installed outdoors.

The power consumption of the water heater is:

Component	Power consumption	Comments
Solar controller	3 Watts	Constant load
Solar pump	115 Watts	Maximum load at solar heating cycle start up (for approximately two (2) minutes)
	40 Watts	Average load during the solar heating cycle
Gas booster	61 Watts	020 - Burner on, anti frost device inactive
	80 Watts	027 - Burner on, anti frost device inactive
	151 Watts	020 - Burner on, anti frost device active
	175 Watts	027 - Burner on, anti frost device active

The water heater will only operate on a sine wave at 50 Hz. Devices generating a square wave cannot be used to supply power to the water heater.

HOT SENSOR LEAD

The plug on the hot sensor lead connected to the solar control board, located behind the front cover of the solar storage tank, is to be connected to the socket on the hot sensor from the solar collector.

To connect the hot sensor leads together:

- Feed the hot sensor lead from the solar collector through the jacket penetration, located to the left of the access cover of the solar storage tank
- Connect the plug on the hot sensor lead from the solar control board to the socket on the hot sensor lead from the solar collector.
- Place the gland around the hot sensor lead from the solar collector, no less than 300 mm from the sensor lead socket, close and lock the gland and insert into the jacket penetration.

The 300 mm distance should leave sufficient excess lead inside of the water heater jacket.

Ensure the gland is placed on the hot sensor lead external to the water heater.

- Secure the hot sensor lead to the side of the solar storage tank using the cable tie mounts provided to prevent possible damage to the lead.
- Secure the hot sensor lead to the accessible insulated pipe work using the cable ties provided.

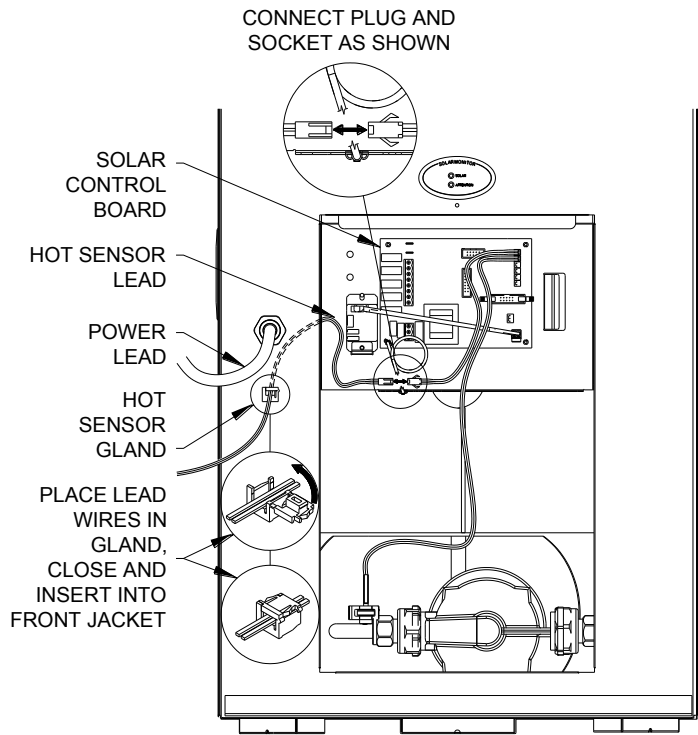

WIRING DIAGRAM

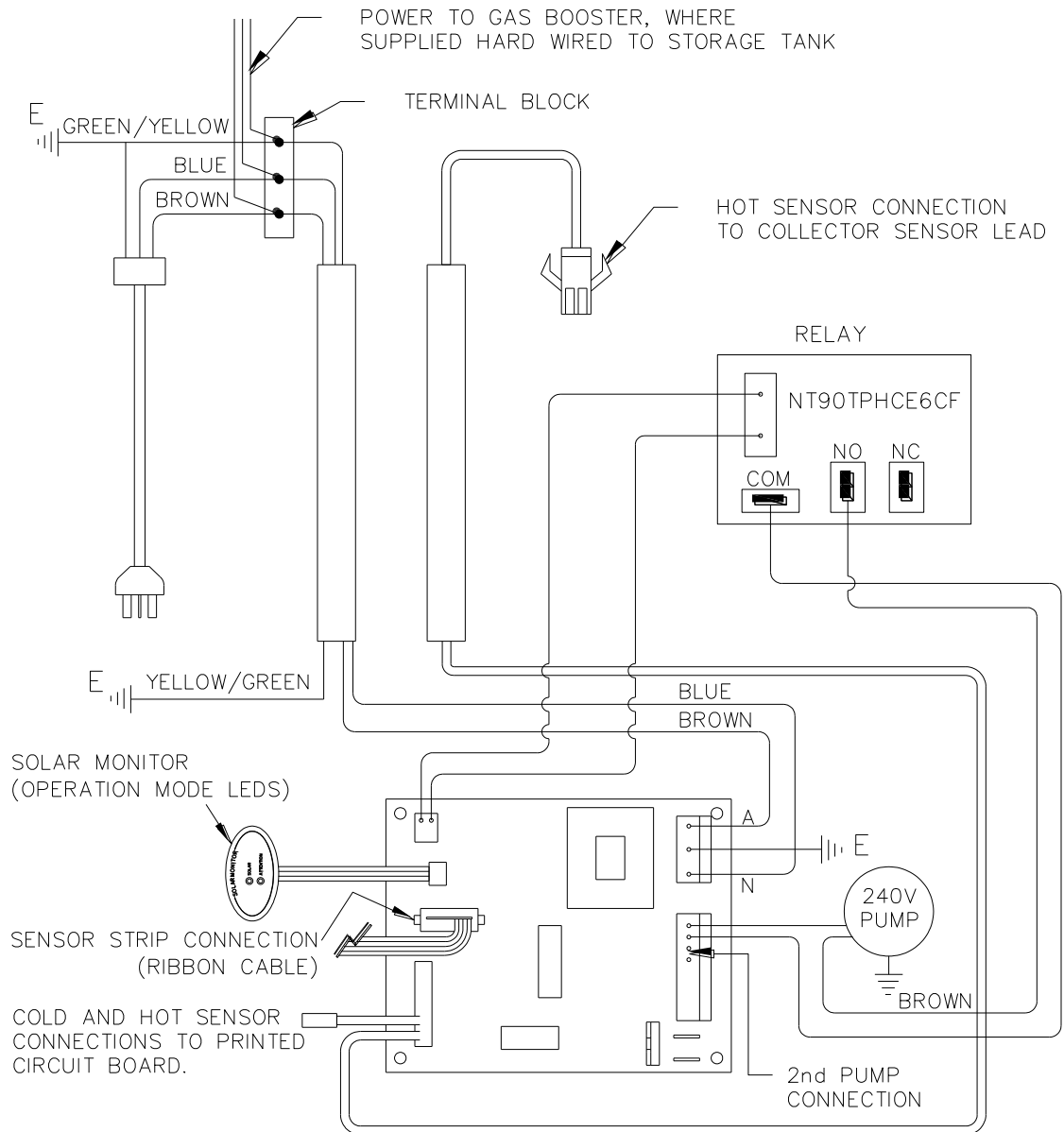

COMMISSIONING

TO FILL AND TURN ON THE WATER HEATER

The power supply to the water heater must not be switched on until the solar storage tank is filled with water.

To fill the solar storage tank with water and turn on the water heater:

- Open all of the hot water taps in the house (don't forget the shower).
- Open the cold water isolation valve fully on the cold water line to the water heater.
Air will be forced out of the taps.
- Close each tap as water flows freely from it.
- Check the pipe work for leaks.
- Open the gas isolation valve fully.
- Check the gas pipe work for leaks.
- Plug in the solar storage tank and in-series gas booster at the power outlets.
- Commission the solar circuit (refer to [“Solar Circuit”](#) on page 47).
- Switch on the electrical supply at the power outlets to each of the solar storage tank and in-series gas booster.

The power outlet must be switched on for the solar controls to operate and solar gain to be achieved and for the in-series gas booster to operate and have its frost protection activated.

- Open a hot tap.
The in-series gas booster will operate automatically.
- Check to ensure the flow from each connected hot tap is sufficient to operate a continuous flow in-series gas booster.
The minimum operating flow rate for all models is 2.7 litres per minute.
- Check the gas inlet and burner gas pressure of the in-series gas booster (refer to [“Gas Inlet Pressure”](#) on page 58 and [“Burner Gas Pressure”](#) on page 58).
- Check and if required adjust the preset outlet temperature or thermostat setting of the in-series booster.
Refer to [“Preset Outlet Temperature Setting”](#) on page 58.

Explain to the householder or a responsible officer the functions and operation of the solar water heater.

⚠ Warning: Upon completion of the installation and commissioning of the water heater, leave this guide with the householder or a responsible officer. **DO NOT** leave this guide inside of the cover of the water heater, as it may interfere with the safe operation of the water heater or ignite when the water heater is turned on.

If it is necessary to turn off the water heater on completion of the installation, such as on a building site or where the premises is vacant, follow the procedure [“To Turn Off the Water Heater”](#) on page 59.

SOLAR CIRCUIT

Commissioning of the Solar Circuit

It is necessary to commission and check the operation of the solar circuit as part of the installation. The water heater is supplied charged with closed circuit fluid.

The commissioning procedure includes checking the:

- circulation of closed circuit fluid through the solar circuit.
- drain back function of the solar circuit.
- solar circuit under circulation to ensure there are no leaks.
- level of the closed circuit fluid.

Note: During the commissioning procedure, it **WILL BE** necessary to drain a quantity of the closed circuit fluid from the heat exchanger, to ensure the fluid is at the optimum level to maximise solar gain.

It should not be necessary to add to the level of closed circuit fluid unless there is a significant leak in the solar pipe work and closed circuit fluid has been discharged.

Additional Equipment

Additional equipment will be required for the commissioning and checking of the solar circuit. This includes checking the closed circuit fluid level and conducting a drain back test. The following equipment is required:

- a 1500 mm long x 6 mm (¼") diameter clear hose (closed circuit fluid level hose).
- a suitable plug for one end of the hose.
- suitable tape to affix the hose to the side of the solar storage tank.
- a torch to illuminate the working area under the heat exchanger and storage tank cylinder.
- a non-permanent marker.

Closed Circuit Fluid

The water heater is supplied charged with closed circuit fluid and it is not necessary to add further closed circuit fluid to the system. If the closed circuit fluid has been completely drained or discharged from the solar circuit and needs to be replaced, then the amount to be added is:

- 4.5 litres of concentrate, mixed with
- 4.5 litres of water.

It is necessary to undertake the solar circuit commissioning procedure if the closed circuit fluid has been replaced.

The closed circuit fluid contains food grade additives (rust inhibitor, anti-freeze agent, colour) and is harmless to the environment. However, it is good practice to recover any excess closed circuit fluid and remove from site for appropriate disposal.

⚠ Warning: Although non-toxic, the following first aid advice and procedures should be followed if the closed circuit fluid concentrate comes into human contact or is spilt:

- Swallowed - give milk or water and seek medical attention.
- Eyes - wash with running water.
- Skin - remove contaminated clothing and wash skin with water and soap.
- Inhaled - seek fresh air, rest and keep warm.
- Spilt - immediately remove contaminated clothing, stop leak source, absorb with a dry agent and eliminate any ignition sources nearby.

⚠ PRE-COMMISSIONING WARNINGS

- It is recommended to conduct the solar circuit commissioning procedure with the solar collector covered, otherwise during the commissioning and checking procedure of the solar circuit, the closed circuit fluid may experience solar gain as it passes through the solar collector. This will increase both the temperature and pressure of the closed circuit fluid and vapour inside of the solar circuit.
- The electrical supply must be switched off before the solar circuit is opened either at the solar circuit relief valve or at the compression nut on either of the solar hot or solar cold pipes at the top of the solar storage tank.
- If it is necessary to open the solar circuit at the solar circuit relief valve or at the compression nut on either of the solar hot or solar cold pipes at the top of the solar storage tank, then care must be taken so as not to be scalded by either the closed circuit fluid or the vapour escaping from the solar circuit.

Pre-Commissioning Notes

- Before commencing the solar circuit commissioning procedure, check the solar cold and solar hot pipe work to ensure:
 - there is a continuous fall from the solar collector to the solar storage tank of a minimum 5° (1 in 10 grade).
 - the maximum recommended pipe length is not exceeded.
 - the maximum height from the base of the solar storage tank to the solar collector is not exceeded.

Rectify the solar pipe work if there is either insufficient fall or not a continuous fall of at least 5° from the solar collector to the solar storage tank or if either of the maximum pipe length or maximum height of the system has been exceeded, before commencing the solar circuit commissioning procedure. Refer to “[Pipe Lengths](#)” on page 34.

- The solar collector will gain a high level of heat during periods of solar radiation. If the solar pump is activated during a period of high solar radiation and the solar collector has not been covered, the initial flow of closed circuit fluid will absorb this heat and a rumbling sound may be heard. This is normal and the solar circuit will achieve a stable operating condition once full flow through the solar circuit is established.
- The solar pump is set on the speed setting 3. This speed setting must not be adjusted. The solar control unit automatically controls and adjusts the speed of the pump to maximise solar contribution. Manual adjustment of the speed dial setting may result in the system not operating correctly or efficiently.

Commissioning the Solar Circuit

To commission and check the solar circuit:

1. Switch off the electrical supply at the power outlets to the solar storage tank and in-series gas booster.
If the pump has been operating, wait five minutes to allow the drain back of the closed circuit fluid in the solar circuit.
2. Cover the solar collector with an opaque material to prevent solar gain during the commissioning process.
3. Remove the screw from the front jacket securing the lower front cover in position and remove the cover from the solar storage tank.

Attach Closed Circuit Fluid Level Hose

4. Attach the clear hose to the solar circuit.

To attach the hose:

- Ensure the heat exchanger drain valve is closed.

The heat exchanger drain valve is located in the centre on the underside of the cylinder, behind the lower front cover of the solar storage tank.

- Attach one end of the hose to the hose tail connection.
- Plug the free end of the hose.
- Affix the hose securely in a vertical orientation to the front of the solar storage tank using tape, adjacent to the text, "MINIMUM FLUID LEVEL WITH PUMP OPERATING" and ensure there are no kinks in the hose.

5. Disconnect the drain line from the solar circuit relief valve at the top of the solar storage tank. Remove the spring clip from the solar circuit relief valve and remove the valve.

⚠ Warning: The solar circuit may be under pressure. Take care when removing the solar circuit relief valve, as a sudden discharge of pressurised hot vapour may be experienced. This discharge will create a sharp sound of vapour being released.

6. Open the heat exchanger drain valve and remove the plug from the end of the hose.

The closed circuit fluid will flood the hose to the static level of the closed circuit fluid inside of the heat exchanger.

7. Mark the static level of the closed circuit fluid on the side of the solar storage tank with a non permanent marker.

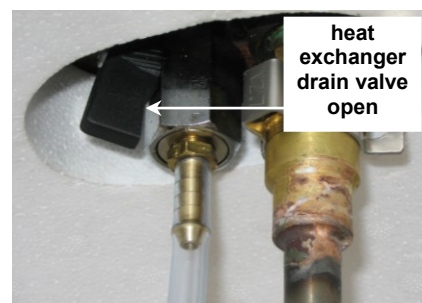
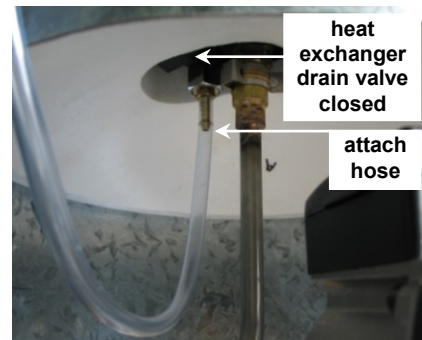

Solar Circuit Circulation

8. Disconnect the hot sensor lead from the solar control board inside of the lower front cover of the solar storage tank.

It is important, at the end of this procedure when the commissioning and checking of the solar circuit is complete, **to reconnect the hot sensor lead**, otherwise when the electrical supply is switched on, the solar pump will deactivate after one hour and the solar control unit will then enter a fault mode and no solar gain will be achieved.

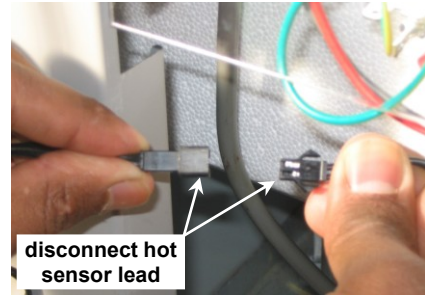

9. Switch on the electrical supply at the power outlet to the solar storage tank.

⚠ Warning: Take care not to enter the area inside the solar storage tank behind the lower front cover whilst the power is on as the electrical circuit will be live.

The red LED on the solar monitor label, located above the lower front cover opening, will start flashing.

The pump will activate and commence pumping closed circuit fluid around the solar circuit.

The level of the closed circuit fluid in the clear hose will slowly drop to the dynamic operating level.

Allow the pump to operate for three (3) minutes (one or two collector systems) to allow the solar circuit to fill with closed circuit fluid and stabilise.

Note: The solar pump will operate for one hour with the hot sensor lead disconnected, before automatically turning itself off ([refer to step 12](#)).

10. Check the closed circuit fluid is circulating around the solar circuit.

To check circulation:

- Listen for the trickling sound of the closed circuit fluid returning into the heat exchanger by placing your ear against the side toward the top of the solar storage tank.

If the fluid is circulating around the solar circuit, a trickling sound will be heard as the fluid returns back into the heat exchanger.

If no trickling sound is heard, check:

- ♦ the hot sensor lead is disconnected at the solar storage tank.

If connected, disconnect the hot sensor lead at the solar storage tank ([refer to step 8](#)).

⚠ Warning: Switch off the electrical supply at the power outlet to the solar storage tank before entering the area inside the solar storage tank behind the lower front cover.

- ♦ there is no leakage from the solar circuit. It is important to check all of the solar circuit pipe work, including in the roof space and on the roof.

If leaking, rectify any leaks in the solar circuit.

- ♦ the height from the base of the storage tank to the top of the collector has not exceeded the maximum allowable height.
- ♦ the length of solar cold and solar hot pipe has not exceeded the maximum recommended pipe length.

If the maximum allowable height or the maximum recommended pipe length has been exceeded, it may be necessary to relocate the solar collector to either a lower level or closer to the solar storage tank, or relocate the solar storage tank closer to the solar collector. Refer to [“Pipe Lengths”](#) on page 34.

11. Mark the dynamic level of the closed circuit fluid in the hose on the side of the solar storage tank with a non permanent marker when satisfied the solar circuit circulation is operating satisfactorily.
12. If the procedure to check the solar circuit circulation is not complete before the pump has automatically turned off, then:
 - switch off the electrical supply at the power outlet to the solar storage tank.
 - recommence this procedure from [step 9](#).

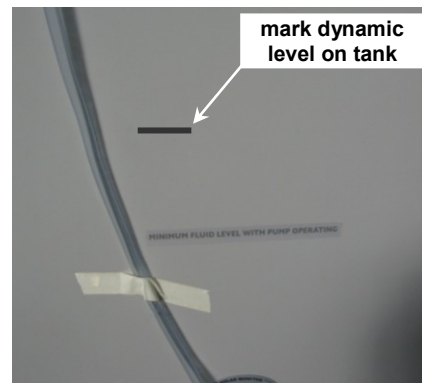

Drain Back Function

13. Switch off the electrical supply at the power outlet to the solar storage tank.

The red LED on the solar monitor label will stop flashing.

The pump will deactivate.

The closed circuit fluid will drain back down to the heat exchanger and the level of the closed circuit fluid in the clear hose will rise.

Wait three (3) minutes to allow the drain back of the closed circuit fluid in the solar circuit.

14. Note the level of the closed circuit fluid in the fluid level hose.

The closed circuit fluid should drain back to the original static level.

If the closed circuit fluid does not drain back completely to this level, then check:

- there is a continuous fall of at least 5° (1 in 10 grade) in the solar pipe work from the solar collector to the solar storage tank.
- the solar collector has an inclination of not less than 10°.

(refer to “[Solar Collector Location](#)” on page 33)
- the connectors on the inlet and outlet of the collector are orientated downwards to ensure complete drain back of the closed circuit fluid from the solar collector.

If necessary, rectify the:

- solar pipe work if there is either insufficient fall or not a continuous fall in the pipe work.
- solar collector inclination if it is less than 10°.
- orientation of the connectors downwards if they are not orientated correctly.

Recheck the drain back function of the solar circuit by repeating [step 7](#) and recommencing this procedure from [step 9](#).

Closed Circuit Fluid Level

15. Measure the distance from the text marking “MINIMUM FLUID LEVEL WITH PUMP OPERATING” to the closed circuit fluid dynamic level marked on the side of the solar storage tank during [step 11](#).

The correct closed circuit fluid dynamic level for efficient operation of the system when the pump is operating, is between the “MINIMUM FLUID LEVEL WITH PUMP OPERATING” text marking on the side of the solar storage tank and 150 mm above this mark.

- If the closed circuit fluid dynamic level marked on the side of the solar storage tank during [step 11](#) is greater than 150 mm above the text marking, it will be necessary to drain closed circuit fluid from the heat exchanger.

It is preferred to obtain a closed circuit fluid dynamic level close to and above or level with the “MINIMUM FLUID LEVEL WITH PUMP OPERATING” text marking on the side of the solar storage tank.

- If the closed circuit fluid dynamic level is below the text marking, it will be necessary to add water to the heat exchanger to top up the level of closed circuit fluid.

There is sufficient closed circuit fluid concentrate in the solar circuit heat exchanger such that only water needs to be added to the system if it is required to top up the level of closed circuit fluid.

Note: The dynamic level of the closed circuit fluid, upon the completion of commissioning, must not be less than the “MINIMUM FLUID LEVEL WITH PUMP OPERATING” text marking on the side of the solar storage tank or greater than 150 mm above this mark.

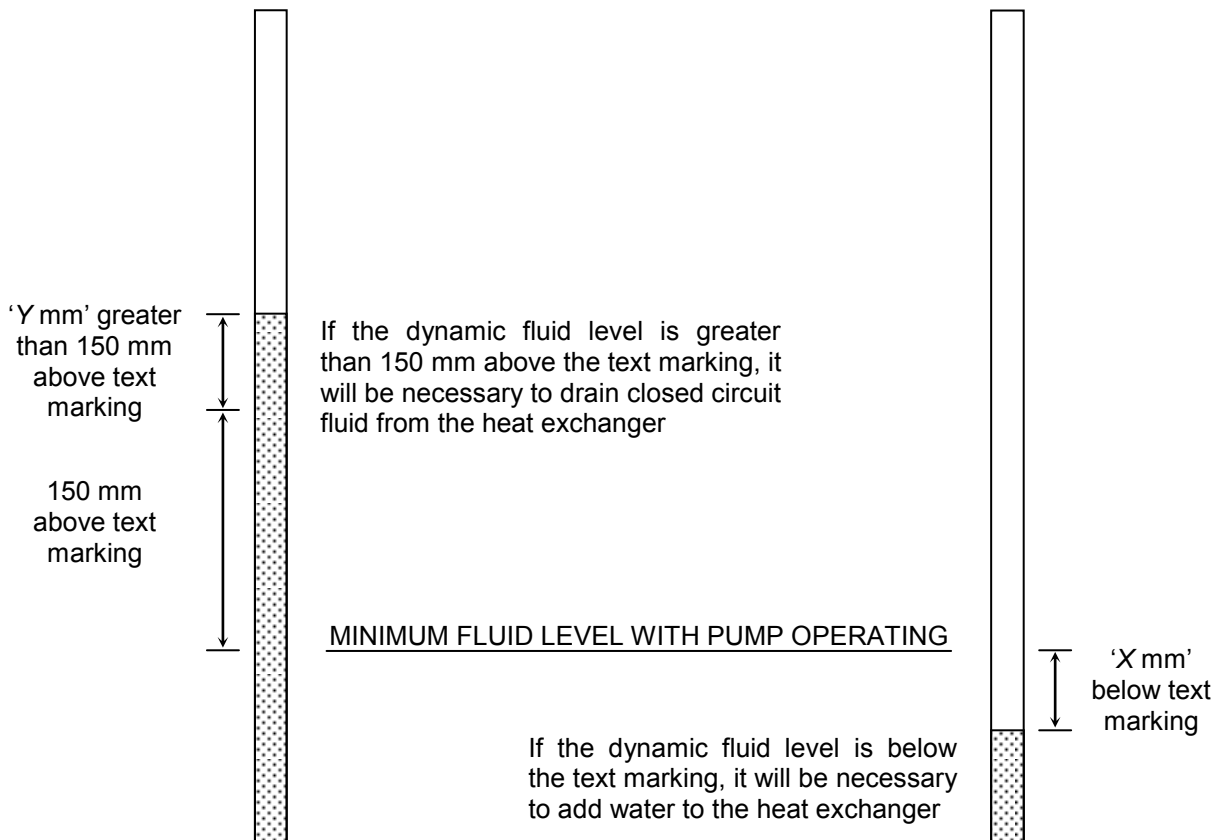

16. Determine the correct amount of water to be added to or closed circuit fluid to be drained from the heat exchanger if the dynamic level is either below the text marking “MINIMUM FLUID LEVEL WITH PUMP OPERATING” or more than 150 mm above this mark.

Each 100 mm of fluid level height is equivalent to 730 ml (0.73 litres) of closed circuit fluid.

50 mm	0.37 litres	250 mm	1.83 litres	450 mm	3.29 litres
100 mm	0.73 litres	300 mm	2.19 litres	500 mm	3.65 litres
150 mm	1.10 litres	350 mm	2.56 litres	550 mm	4.02 litres
200 mm	1.46 litres	400 mm	2.92 litres	600 mm	4.38 litres

- Mark the required closed circuit fluid level to be obtained on the side of the solar storage tank with a non permanent marker beside the clear hose, in relation to the static level marked on the side of the solar storage tank during [step 7](#).

It is preferred to obtain a closed circuit fluid dynamic level close to and above or level with the “MINIMUM FLUID LEVEL WITH PUMP OPERATING” text marking on the side of the solar storage tank.

E.g.: If the dynamic level is 70 mm below the text marking, then place a mark 70 mm above the static level marked on the side of the solar storage tank in [step 7](#). It would be necessary to add just over half a litre (510 ml) of water to the heat exchanger.

E.g.: If the dynamic level is 180 mm above the text marking, then place a mark at least 30 mm, but no more than 180 mm, below the static level marked on the side of the solar storage tank. It would be necessary to drain between 220 ml and 1300 ml of closed circuit fluid from the heat exchanger.

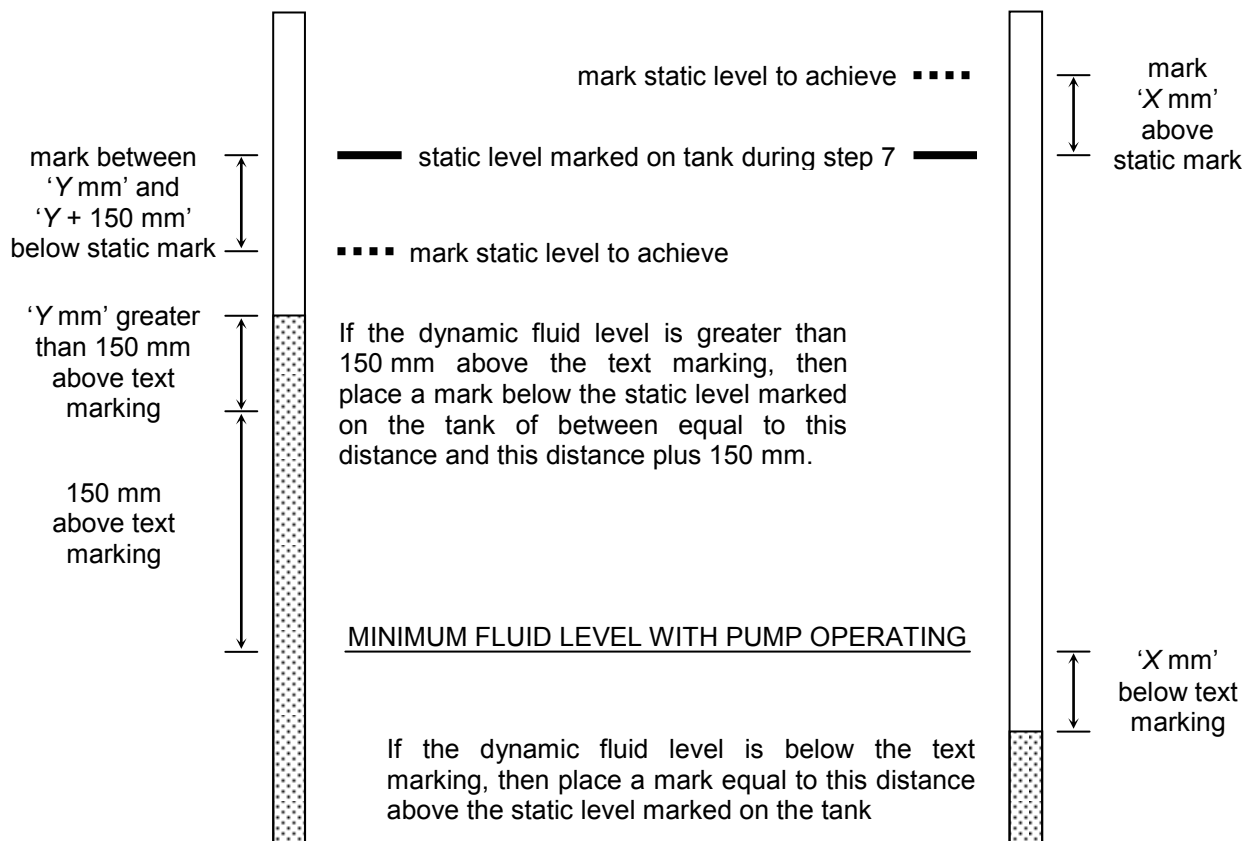

17. Measure into a container the amount of water to be added to top up the level of the closed circuit fluid in the heat exchanger if required.

To add water to the closed circuit fluid:

- If not already removed, disconnect the drain line and remove the spring clip from the solar circuit relief valve at the top of the solar storage tank and remove the valve ([refer to step 5](#)).

⚠ Warning: The solar circuit may be under pressure. Take care when removing the solar circuit relief valve, as a sudden discharge of pressurised hot vapour may be experienced. This discharge will create a sharp sound of vapour being released.

- Undo the compression nut on the solar cold pipe at the top of the solar storage tank and remove the pipe work from the fitting.
- Place a funnel in the solar cold connection fitting at the top of the solar storage tank.
- Add water slowly through the funnel until the level of fluid in the hose is at the desired level as marked on the solar storage tank.

Note: It may be necessary to either lift the funnel slightly to allow air to escape around the funnel whilst filling.

- Remove the funnel from the solar cold connection fitting.
- Position the solar cold pipe correctly in its fitting and tighten the compression nut.

18. Drain closed circuit fluid from the heat exchanger if required.

To drain closed circuit fluid:

- Place the end of the solar fluid hose into a graduated volumetric container and drain closed circuit fluid until the calculated volume of fluid has been drained or the level of fluid in the hose is at the desired level as marked on the solar storage tank.

It may be necessary to drain off the closed circuit fluid in small amounts, raising the hose back to the top of the solar storage tank and noting the level of the closed circuit fluid in the clear hose each time, so as not to drain below the desired level.

Note: The closed circuit fluid contains food grade additives (rust inhibitor, anti-freeze agent, colour) and is harmless to the environment. However, it is good practice to recover any excess fluid and remove from site for appropriate disposal.

- Re-affix the hose to the same location on the side of the solar storage tank.

19. If water has been added to or closed circuit fluid has been drained from the heat exchanger, recommence this procedure from [step 9](#).

Checking the Solar Circuit for Leaks

20. Close the heat exchanger drain valve.
21. Refit the solar circuit relief valve, orientating the valve outlet to the rear of the solar storage tank. Secure with the spring clip. Reconnect the drain pipe to the valve.
22. Switch on the electrical supply at the power outlet to the solar storage tank.



⚠ Warning: Take care not to enter the area inside the solar storage tank behind the lower front cover whilst the power is on as the electrical circuit will be live.

The red LED on the solar monitor label will start flashing and the pump will activate and commence pumping fluid around the solar circuit.

Note: The level of the closed circuit fluid in the clear hose will not change, as the heat exchanger drain valve has been closed.

Allow the pump to operate for three (3) minutes to allow the solar circuit to stabilise and fill with closed circuit fluid.

Note: The solar pump will operate for one hour with the hot sensor lead disconnected, before automatically turning itself off. Refer to [step 24](#).

23. Check the solar pipe work and collector unions for leaks whilst the pump is operating and the solar circuit is at its working pressure. It is important to check all of the solar circuit pipe work, including in the roof space and on the roof.
24. If the procedure to check the solar pipe work for leaks is not complete before the pump has automatically turned off, then:
 - switch off the electrical supply at the power outlet to the solar storage tank.
 - recommence this procedure from [step 22](#).
25. Switch off the electrical supply at the power outlet to the solar storage tank.

The red LED on the solar monitor label will stop flashing and the pump will deactivate.

The closed circuit fluid will drain back down to the heat exchanger.

26. Rectify any leaks in the solar pipe work and collector unions.

If brazing is required to fix any leaks, then it is necessary to remove the solar circuit relief valve ([refer to step 5](#)).

⚠ Warning: The solar circuit may be under pressure. Take care when removing the solar circuit relief valve, as a sudden discharge of pressurised hot vapour may be experienced. This discharge will create a sharp sound of vapour being released.

27. If minor leaks have been rectified, recommence this procedure from [step 22](#). If a major leak has been rectified, recommence this procedure from [step 5](#).

Remove Closed Circuit Fluid Level Hose

28. Remove the clear hose from the solar storage tank when satisfied the commissioning procedure is complete.

To remove the hose:

- Ensure the heat exchanger drain valve is closed.
- Remove the hose from the side of the storage tank and place the end into a container to collect the closed circuit fluid in the hose.
- Replace the plug into the free end of the hose and lay the hose flat on the ground.
- Loosen the hose clamp, if fitted, and carefully remove the hose and hose clamp from the heat exchanger drain valve fitting, ensuring there is no spillage of any remaining closed circuit fluid.

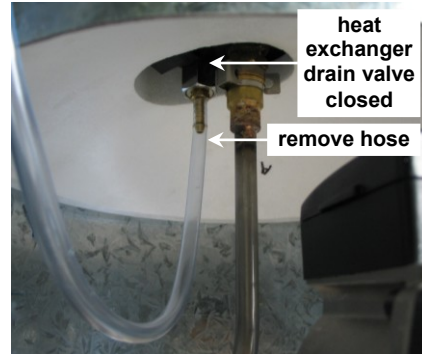

Clean up any spillage of closed circuit fluid.

- Place the open end of the hose into the container and recover the remainder of the closed circuit fluid from the hose.

Note: The closed circuit fluid contains food grade additives (rust inhibitor, anti-freeze agent, colour) and is harmless to the environment. However, it is good practice to recover any excess closed circuit fluid and remove from site for appropriate disposal.

Completing the Commissioning of the Solar Circuit

29. Reconnect the hot sensor plug into the hot sensor connection socket on the control board located behind the lower front cover.

It is important to reconnect the hot sensor lead, otherwise when the electrical supply is switched on, the solar pump will deactivate after one hour and the solar control unit will then enter a fault mode, will not operate and no solar gain will be achieved.

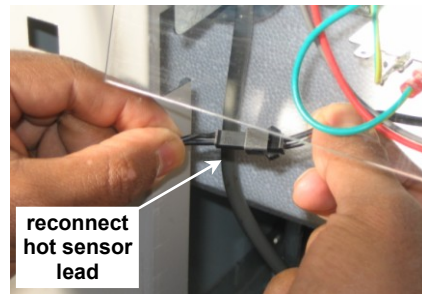

30. Replace the lower front cover of the solar storage tank and secure by refitting the screw into the lower front jacket.
31. Clean off the marks made on the side of the solar storage tank.
32. Remove the covers from the solar collector.
33. Switch on the electrical supply at the power outlet to the solar storage tank.

DIAGNOSTIC FEATURES OF THE SOLAR CONTROLLER

The solar storage tank incorporates a solar monitor which is connected to the solar control module by a ribbon cable. The solar monitor is located above the lower front cover and houses both a green and a red LED.

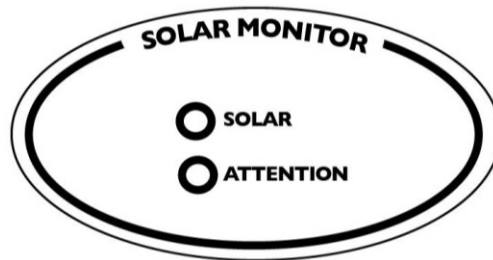

The green LED, marked “Solar”, indicates the current operational mode of the solar water heater and the red LED, marked “Attention”, indicates a fault mode.

The green LED will emit either a constant glow or a series of flashes, with a 2 second interval between each series.

The red LED will emit a series of flashes, with a 2 second interval between each series, only if there is a particular fault condition with the system.

The modes are:

Flashes	Operational Modes
solid green (remains on)	Standby mode
2 x green	Flooding solar circuit
3 x green	Pump flow control
4 x green	Pump flow established
5 x green	Tank at maximum temperature
no green (remains off)	Call for service

Flashes	Fault Modes
1 x red	Hot sensor in collector – open circuit
2 x red	Hot sensor in collector – short circuit
3 x red	Cold sensor – open or short circuit
4 x red	Top three tank thermistors – open or short circuit
5 x red	Sensor strip plugged into incorrect port on printed circuit board (PCB)
6 x red	No heating fluid flow through collector

If the power supply to the water heater is on and the green LED is off or the red LED is flashing, this indicates there is a fault with the water heater. The red LED may emit up to six flashes in each series of flashes. Count the number of flashes and phone Rheem Service or their nearest Accredited Service Agent to arrange for an inspection.

IN-SERIES BOOSTER

Refer to the Owner's Guide and Installation Instructions supplied with the in-series booster for the commissioning procedure of the water heater.

If a gas water heater has been installed as an in-series booster to the solar water heater, then to complete the installation, it is necessary to check the gas supply pressure at the inlet to the in-series gas booster, and also the minimum test point pressure and the maximum test point pressure of the in-series gas booster. Refer to "Gas Inlet Pressure" on page 58 and to "Burner Gas Pressure" on page 58.

PRESET OUTLET TEMPERATURE SETTING

Note: AS 3498 requires that a water heater provides the means to inhibit the growth of Legionella bacteria in potable water. If this water heater is installed with an continuous flow in-series gas booster, then this requirement of AS 3498 can be satisfied provided the booster is energised, its preset outlet temperature setting is 70°C or higher and a remote temperature controller is not used.

If this water heater is installed with an in-series storage booster, then this requirement of AS 3498 can be satisfied provided the storage booster is energised and its thermostat setting is 60°C or higher.

It will be necessary to check and if required to adjust the preset outlet temperature setting of the continuous flow water heater or the thermostat setting of a storage water heater when it is installed as an in-series booster to a solar water heater or if it is an existing water heater and a solar water heater is then installed.

Refer to the Owner's Guide and Installation Instructions supplied with the continuous flow in-series gas booster for the procedure to check and adjust the preset outlet temperature if required.

Refer to the Owner's Guide and Installation Instructions supplied with the in-series storage booster for the procedure to check and adjust the thermostat setting if required.

Note: Consideration must be given to the delivery temperature to any ablution and public areas such as a bathroom, ensuite or public amenities. Refer to "Hot Water Delivery" on page 26 and to the schematics of "Two Temperature Zones Using A Temperature Limiting Device" on page 26.

GAS INLET PRESSURE

IMPORTANT - CHECK the gas supply pressure at the inlet to the water heater with the water heater and all other gas burning appliances in the premises operating (burners alight). The minimum gas supply pressure is:

Natural Gas	1.13 kPa	Propane	2.75 kPa
-------------	----------	---------	----------

If this minimum cannot be achieved, it may indicate the meter or the gas line to the water heater is undersized. It is important to ensure that an adequate gas supply pressure is available to the water heater when other gas burning appliances, on the same gas supply, are operating.

Refer to the "Gas Inlet Test Point Pressure" section of the Installation Instructions and Owner's Guide supplied with the in-series gas booster.

BURNER GAS PRESSURE

It is necessary to check the burner gas pressure at both the minimum and maximum operational settings. To check and if necessary adjust the operational gas pressures, the electrical supply to the in-series gas booster must be switched on, the burners ignited and hot water must be flowing from a hot tap.

 **Warning:** The removal of the front cover will expose 240 volt wiring. Take care not to touch wiring terminals.

Refer to the "Minimum Test Point Gas Pressure" and "Maximum Test Point Gas Pressure" sections of the Installation Instructions and Owner's Guide supplied with the continuous flow in-series gas booster.

TO TURN OFF THE WATER HEATER

If it is necessary to turn off the water heater on completion of the installation, such as on a building site or where the premises is vacant, then:

- Switch off the electrical supply at the power outlets to the solar storage tank and in-series gas booster (refer to note below).
- Close the gas isolation valve at the inlet to the water heater.
- Close the cold water isolation valve at the inlet to the water heater.
- Drain the in-series gas booster if there is a risk of freezing conditions occurring (refer to [“Draining The Water Heater”](#) on page 60).

Notes:

- The frost protection system of the in-series gas booster will be rendered inoperable if electrical power is not available at the gas booster. Damage caused by freezing due to the unavailability of power at the in-series gas booster is not covered by the Vulcan warranty.
- If the power has been switched off to the in-series gas booster and there is a risk of freezing, then it is necessary to drain the gas booster (refer to [“Draining the Water Heater”](#) on page 60).
- Refer to [“Terms of the Vulcan Warranty”](#) on page 63.

DRAINING THE WATER HEATER

GAS BOOSTER WATER HEATER

To drain the in-series gas booster:

- Turn off the water heater (refer to “[To Turn Off The Water Heater](#)” on page 59).
- Open a hot tap (preferably the shower outlet).
- Unscrew the two drain plugs, one each at the cold water inlet and hot water outlet, on the underside of the in-series gas booster.

Water will drain from the in-series gas booster.

- When water stops flowing from the in-series gas booster, close the hot tap.

Note: It is recommended not to screw the drain plugs back in, until the water heater is to be turned on again.

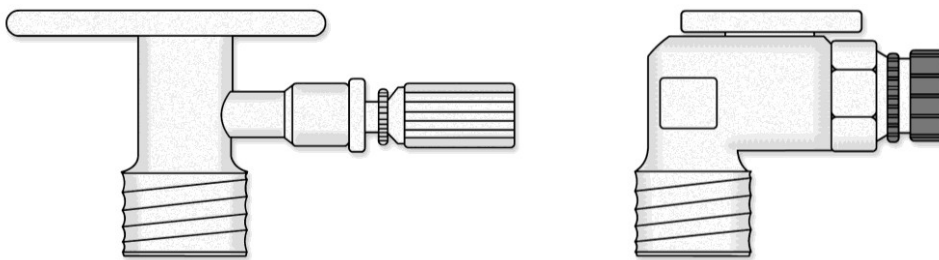

SOLAR STORAGE TANK

⚠ Warning: Exercise care, as water discharged from the solar storage tank may be of a very high temperature.

To drain the storage tank:

- Turn off the water heater (refer to “[To Turn Off The Water Heater](#)” on page 59).
- Close all hot water taps.
- Operate the relief valve release lever - do not let the lever snap back or you will damage the valve seat.

Operating the lever will release the pressure in the water heater.

- Undo the union at the cold water inlet to the solar storage tank and attach a hose to the water heater side of the union.

Let the other end of the hose go to a drain.

- Operate the relief valve again.

This will let air into the water heater and allow the water to drain through the hose.

HEAT EXCHANGER

⚠ Warning: Exercise care, as fluid discharged from the heat exchanger may be of a very high temperature.

To drain the closed circuit heat exchanger:

- Switch off the electrical supply at the power outlet to the solar storage tank.
- Remove the lower front cover from the solar storage tank.
- Attach a 10 mm (3/8") diameter clear hose to the heat exchanger drain valve hose tail connection (refer to step 4 of "[Attach Closed Circuit Fluid Level Hose](#)" on page 49).
- Disconnect the drain line from the solar circuit relief valve at the top of the solar storage tank. Remove the spring clip from the solar circuit relief valve and remove the valve.

⚠ Warning: The solar circuit may be under pressure. Take care when removing the solar circuit relief valve, as a sudden discharge of pressurised hot vapour may be experienced. This discharge will create a sharp sound of vapour being released.

- Open the heat exchanger drain valve and remove the plug from the end of the hose.
- The closed circuit fluid will flood the hose.
- Place the end of the hose into a container and drain the closed circuit fluid from the heat exchanger.

Note: The heat exchanger can contain up to 11 litres of closed circuit fluid. A suitably sized container should be used to accommodate this amount of fluid.

The closed circuit fluid contains food grade additives (rust inhibitor, anti-freeze agent, colour) and is harmless to the environment. However, it is good practice to recover any excess closed circuit fluid and remove from site for appropriate disposal.

This page is intentionally blank.

VULCAN SOLAR WATER HEATER WARRANTY

– AUSTRALIA ONLY –

SOLAR WATER HEATER MODEL 590160

1. THE VULCAN WARRANTY – GENERAL

- 1.1 This warranty is given by Rheem Australia Pty Limited ABN 21 098 823 511 of 1 Alan Street, Rydalmere New South Wales, the manufacturer of Vulcan mains pressure water heaters.
- 1.2 Rheem offer a trained and qualified national service network who will repair or replace components at the address of the water heater subject to the terms of the Vulcan warranty. Rheem Service, in addition can provide preventative maintenance and advice on the operation of your water heater. The Rheem Service contact number is available 7 days a week on 131031 with Service personnel available to take your call from 8am to 8pm daily (hours subject to change).
- 1.3 For details about this warranty, you can contact us on 131031 or by email at warrantyenquiry@rheem.com.au (not for service bookings).
- 1.4 The terms of this warranty are set out in section 2 and apply to water heaters manufactured after 1st January 2012.
- 1.5 If a subsequent version of this warranty is published, the terms of that warranty will apply to water heaters manufactured after the date specified in the subsequent version.

2. TERMS OF THE VULCAN WARRANTY AND EXCLUSIONS TO IT

- 2.1 The decision of whether to repair or replace a faulty component is at Rheem's sole discretion.
 - 2.2 If you require a call out and we find that the fault is not covered by the Vulcan warranty, you are responsible for our standard call out charge. If you wish to have the relevant component repaired or replaced by Rheem, that service will be at your cost.
 - 2.3 Where a failed component or cylinder is replaced under this warranty, the balance of the original warranty period will remain effective. The replacement does not carry a new Vulcan warranty.
 - 2.4 Where the water heater is installed outside the boundaries of a metropolitan area as defined by Rheem or further than 25 km from either a regional Rheem branch office or an Accredited Rheem Service Agent's office, the cost of transport, insurance and travelling between the nearest branch office or Rheem Accredited Service Agent's office and the installed site shall be the owner's responsibility.
 - 2.5 Where the water heater is installed in a position that does not allow safe or ready access, the cost of that access, including the cost of additional materials handling and/or safety equipment, shall be the owner's responsibility. In other words, the cost of dismantling or removing cupboards, doors or walls and the cost of any special equipment to bring the water heater to floor or ground level or to a serviceable position is not covered by this warranty.
 - 2.6 This warranty only applies to the original and genuine Vulcan water heater in its original installed location and any genuine Vulcan replacement parts.
 - 2.7 The Vulcan warranty does not cover faults that are a result of:
 - a) Accidental damage to the water heater or any component (for example: (i) Acts of God such as floods, storms, fires, lightning strikes and the like; and (ii) third party acts or omissions).
 - b) Misuse or abnormal use of the water heater.
 - c) Installation not in accordance with the Owner's Guide and Installation Instructions or with relevant statutory and local requirements in the State or Territory in which the water heater is installed.
 - d) Connection at any time to a water supply that does not comply with the water supply guidelines as outlined in the Owner's Guide and Installation Instructions.
 - e) Repairs, attempts to repair or modifications to the water heater by a person other than Rheem Service or a Rheem Accredited Service Agent.
 - f) Faulty plumbing or faulty gas or power supply.
 - g) Failure to maintain the water heater in accordance with the Owner's Guide and Installation Instructions.
 - h) Transport damage.
 - i) Fair wear and tear from adverse conditions (for example, corrosion).
 - j) Cosmetic defects.
 - k) Breakage of collector glass for any reason including hail damage (we suggest that the collector glass be covered by your home insurance policy).
 - l) Ice formation in the closed circuit system due to non Rheem approved or incorrectly mixed closed circuit fluid being used.
 - m) Non Rheem approved or incorrectly mixed closed circuit fluid being used or incorrect or insufficient filling of the closed circuit system with the closed circuit fluid.
 - 2.8 Subject to any statutory provisions to the contrary, this warranty excludes any and all claims for damage to furniture, carpet, walls, foundations or any other consequential loss either directly or indirectly due to leakage from the water heater, or due to leakage from fittings and/ or pipe work of metal, plastic or other materials caused by water temperature, workmanship or other modes of failure.
 - 2.9 If the water heater is not sized to supply the hot water demand in accordance with the guidelines in the Vulcan water heater literature, any resultant fault will not be covered by the Vulcan warranty.
-

VULCAN SOLAR WATER HEATER WARRANTY

– AUSTRALIA ONLY –

SOLAR WATER HEATER MODEL 590160

3. WHAT IS COVERED BY THE VULCAN WARRANTY FOR THE WATER HEATERS DETAILED IN THIS DOCUMENT

- 3.1 Rheem will repair or replace a faulty component of your water heater if it fails to operate in accordance with its specifications as follows:

What components are covered	The period in which the fault must appear in order to be covered	What coverage you receive
All components	Year 1	Repair and/or replacement of the faulty component, free of charge, including labour.
The cylinder (if the water heater is installed in a single-family domestic dwelling)	Years 2 & 3	Repair and / or replacement of the cylinder, free of charge, including labour.
	Years 4 & 5	Replacement cylinder, free of charge. Installation and repair labour costs are the responsibility of the owner.
The cylinder (if the water heater is <u>not</u> installed in a single-family domestic dwelling)	Years 2 & 3	Replacement cylinder, free of charge. Installation and repair labour costs are the responsibility of the owner.
The solar collector (all installations)	Years 2 to 5	Replacement solar collector, free of charge. Installation and repair labour costs are the responsibility of the owner.

- 3.2 If a government rebate has been received for the water heater, the duration of the protection afforded by this warranty may be greater than what is set out above. Please call 131031 for details.

4. ENTITLEMENT TO MAKE A CLAIM UNDER THIS WARRANTY

- 4.1 To be entitled to make a claim under this warranty you need to:
- a) Be the owner of the water heater or have consent of the owner to act on their behalf
 - b) Contact Rheem Service without undue delay after detection of the defect and, in any event, within the applicable warranty period.
- 4.2 You are **not** entitled to make a claim under this warranty if your water heater:
- a) Does not have its original serial numbers or rating labels.
 - b) Is not installed in Australia.

5. HOW TO MAKE A CLAIM UNDER THIS WARRANTY

- 5.1 If you wish to make a claim under this warranty, you need to:
- a) Contact Rheem on 131031 and provide owner's details, address of the water heater, a contact number and date of installation of the water heater or if that's unavailable, the date of manufacture and serial number (from the rating label on the water heater)
 - b) Rheem will arrange for the water heater to be tested and assessed on-site.
 - c) If Rheem determines that you have a valid warranty claim, Rheem will repair or replace the water heater in accordance with this warranty
- 5.2 Any expenses incurred in the making of a claim under this warranty will be borne by you.

6. THE AUSTRALIAN CONSUMER LAW

- 6.1 Our goods come with guarantees that cannot be excluded under the *Australian Consumer Law*. You are entitled to a replacement or refund for a major failure and for compensation for any other reasonably foreseeable loss or damage. You are also entitled to have the goods repaired or replaced if the goods fail to be of acceptable quality and the failure does not amount to a major failure.
- 6.2 The Vulcan warranty (set out above) is in addition to any rights and remedies that you may have under the *Australian Consumer Law*.

For warranty information on the gas booster, refer to the Owner's Guide and Installation Instructions supplied with the gas booster.

RHEEM AUSTRALIA PTY LTD, A.B.N. 21 098 823 511, www.rheem.com.au
For Service Telephone 131 031 AUSTRALIA or 0800 657 335 NEW ZEALAND