

Owner's Guide and Installation Instructions



Electric Heavy Duty Water Heater



Install a Rheem

*This water heater must be installed and serviced by a qualified person.
Please leave this guide with a responsible officer.*

PATENTS

This water heater may be protected by one or more patents or registered designs.

TRADEMARKS

® Registered trademark of Rheem Australia Pty Ltd.
™ Trademark of Rheem Australia Pty Ltd.

NOTE: Every care has been taken to ensure accuracy in preparation of this publication.
No liability can be accepted for any consequences, which may arise as a result of its application

CONTENTS

RESPONSIBLE OFFICER – We recommend you read pages 4 to 13.

The other pages are intended for the installer but may be of interest.

| | |
|--|-----------|
| About Your Water Heater | 4 |
| Regular Care | 7 |
| Water Supplies..... | 9 |
| Save A Service Call | 12 |
| Installation..... | 14 |
| Connections – Plumbing | 20 |
| Connections – Electrical..... | 22 |
| Multiple Installations | 24 |
| Commissioning..... | 28 |
| Draining The Water Heater | 29 |
| Warranty | 31 |

ABOUT YOUR WATER HEATER

WATER HEATER APPLICATION

This water heater is designed for the purpose of heating potable water. Its use in an application other than this may shorten its life.

MODEL TYPE

The Rheem® Heavy Duty Electric water heater model you have chosen can be installed indoor or outdoor and is either a 50 litre or 315 litre model. The 50 litre has three heating units and the 315 litre has either three or six heating units.

Water is stored in a vitreous enamel lined steel cylinder and heated by either 3 or 6 electric immersion heating units. The temperature is controlled by thermostats. Automatic safety controls are fitted to the water heater to provide safe and efficient operation.

MAINS PRESSURE

The water heater is designed to operate at mains pressure by connecting directly to the mains water supply. If the mains supply pressure in your area exceeds that **shown on page 15**, a pressure limiting valve must be fitted. The supply pressure should be greater than 350 kPa for true mains pressure operation to be achieved.

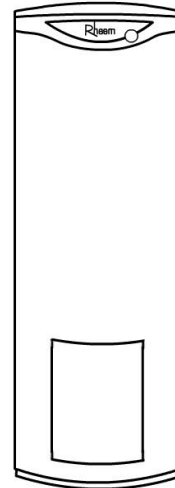

HOW HOT SHOULD THE WATER BE?

The water heater has a maximum temperature setting of 82°C and a minimum temperature setting of 60°C. Refer to **“Temperature Adjustment”** on page 5.

For applications requiring sanitising temperatures, the thermostats should be set at 82°C.

To meet the requirements of the National Plumbing Standard the temperature of the stored water must not be below 60°C.

If this water heater is installed as an in-series booster water heater as part of a solar water heating system, to maximise solar contribution it is recommended the thermostats are set at 60°C, unless sanitising temperatures are required.

Note: AS 3498 requires that a water heater provides the means to inhibit the growth of Legionella bacteria in potable water. This water heater can satisfy this AS 3498 requirement provided it is energised and the thermostat setting is 60°C or higher, including when it is used as an in-series booster water heater for a solar water heater.

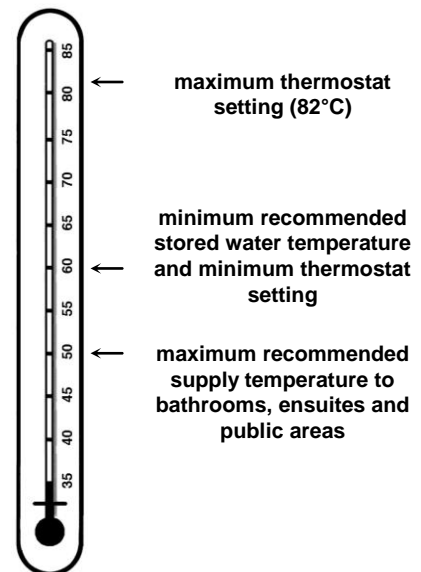

HOTTER WATER INCREASES THE RISK OF SCALD INJURY.

This water heater can deliver water at temperatures which can cause scalding. Check the water temperature before use, such as when entering a shower or filling a bath or basin, to ensure it is suitable for the application and will not cause scald injury.

We recommend and it may also be required by regulations that an approved temperature limiting device be fitted into the hot water pipe work to the bathing and public areas when this water heater is installed. This will keep the water temperature below the maximum permitted by AS/NZS 3500.4 to these areas. The risk of scald injury will be reduced and still allow hotter water to the kitchen, laundry and other areas requiring sanitising temperatures.

THERMOSTATS

The thermostats automatically control the electricity supply to the heating units so a constant temperature is maintained. The thermostats and their protective over temperature cut out are mounted inside the front cover of the water heater. There is no need to switch the water heater off when it is not in use. The thermostats are fully automatic and power is only used when heating is required.

TEMPERATURE ADJUSTMENT

The water heater features tradesperson adjustable thermostats. They require a licensed tradesperson to make any temperature adjustments. We advise the thermostats are adjusted to the lowest temperature setting that meets your needs, especially if there are young children or elderly people in the premises. Refer to **“Hotter Water Increases the Risk of Scald Injury”** on page 4.

WARNING

This water heater is only intended to be operated by persons who have the experience or the knowledge and the capabilities to do so. This water heater is not intended to be operated by persons with reduced physical, sensory or mental capabilities i.e. the infirm, or by children. Children should be supervised to ensure they do not interfere with the water heater.

This water heater uses 240 V AC power for the electrically operated components. The removal of the front cover will expose 240 V wiring. It must only be removed by a qualified person.

SAFETY

This water heater is supplied with a thermostat, an over-temperature cut-out, and a combination temperature pressure relief valve. These devices must not be tampered with or removed. The water heater must not be operated unless each of these devices is fitted and is in working order.

The operation of the over-temperature cut-out on the thermostat indicates a possibly dangerous situation. If the over-temperature cut-out operates, it must not be reset and the water heater must be serviced by a qualified person.

If the electrical conduit to the water heater is damaged, it must be replaced by a qualified person in order to avoid a hazard. Phone Rheem Service or their nearest Accredited Service Agent to arrange for an inspection.

 **Warning:** For continued safety of this water heater it must be installed, operated and maintained in accordance with the Owner's Guide and Installation Instructions.

The Rheem warranty may not cover faults if relief valves or other safety devices are tampered with or if the installation is not in accordance with these instructions.

PRECAUTIONS

Where damage to property can occur in the event of the water heater leaking, the water heater must be installed in a safe tray. Construction, installation and draining of a safe tray must comply with AS/NZS 3500.4 and all local codes and regulatory authority requirements.

The water heater must be maintained in accordance with the Owner's Guide and Installation Instructions. Refer to **“Regular Care”** on page 7 and to **“Anode Inspection and Replacement”** on page 10.

If this water heater is to be used where an uninterrupted hot water supply is necessary for your application or business you should ensure that you have back up redundancy within the hot water system design. This should ensure the continuity of hot water supply in the event that this water heater were to become inoperable for any reason. We recommend you seek advice from your plumber or specifier about your needs and building back up redundancy into your hot water supply system.

TO TURN OFF THE WATER HEATER

If it is necessary to turn off the water heater:

- Switch off the electrical supply at the isolating switch to the water heater(s).
- Close the cold water isolation valve on the cold water line to the water heater(s) to shut down the entire system, or;
- Close the isolation valves on the cold and hot water branches to shut down an individual water heater in a bank.

TO TURN ON THE WATER HEATER

- Open the isolation valves fully on the cold and hot water branches to the water heater(s) installed in a bank.
- Open the cold water isolation valve on the cold water line to the water heater(s). Air will be forced out of the taps.
- Switch on the electrical supply at the isolating switch to the water heater(s).

HOW DO I KNOW IF THE WATER HEATER IS INSTALLED CORRECTLY?

Installation requirements are shown on [pages 14 to 19](#). The water heater must be installed:

- by a qualified person, and
- in accordance with the installation instructions, and
- in compliance with Standards AS/NZS 3500.4, AS/NZS 3000 and all local codes and regulatory authority requirements.

In New Zealand the installation must also conform with the New Zealand Building Code.

VICTORIAN CUSTOMERS

Notice to Victorian Customers from the Victorian Plumbing Industry Commission. This water heater must be installed by a licensed person as required by the Victorian Building Act 1993.

Only a licensed person will give you a Compliance Certificate, showing that the work complies with all the relevant Standards. Only a licensed person will have insurance protecting their workmanship for 6 years. Make sure you use a licensed person to install this water heater and ask for your Compliance Certificate.

DOES THE WATER CHEMISTRY AFFECT THE WATER HEATER?

The water heater is suitable for most public water supplies, however some water chemistries may have detrimental effects on the water heater, its components and fittings. Refer to ["Water Supplies"](#) on page 9.

If you are in a known harsh water area or you are not sure of your water chemistry, have your water checked against the conditions [described on pages 9 to 11](#).

HOW LONG WILL THE WATER HEATER LAST?

The water heater is supported by a manufacturer's warranty ([refer to page 31](#)). There are a number of factors that will affect the length of service the water heater will provide. These include but are not limited to the water chemistry, the water pressure, the water temperature (inlet and outlet) and the water usage pattern. Refer to ["Precautions"](#) on page 5.

REGULAR CARE

MINOR SIX MONTH MAINTENANCE

It is recommended minor maintenance be performed every six months by a responsible officer.

The minor maintenance includes:

- Operate the easing lever on the temperature pressure relief valve. It is very important you raise and lower the lever gently. Refer to “**Temperature Pressure Relief Valve**” on page 8.

⚠ Warning: Exercise care to avoid any splashing of water, as water discharged from the drain line will be hot. Stand clear of the drain line’s point of discharge when operating the valve’s lever.
- Operate the easing lever on the expansion control valve (if fitted). It is very important you raise and lower the lever gently. Refer to “**Expansion Control Valve**” on page 8.
- Check the drain line from the safe tray (if one is installed) is not blocked.

MAJOR FIVE YEAR SERVICE

It is recommended a major five year service be conducted on the water heater. The service must be conducted by a qualified person. Phone Rheem Service or their nearest Accredited Service Agent.

Note: The five year service and routine replacement of any components, such as the anode and relief valve(s), are not included in the Rheem warranty. A charge will be made for this work. Only genuine replacement parts should be used on this water heater.

The major service includes the following actions:

- Replace the temperature pressure relief valve.
- Inspect and flush the expansion control valve (if fitted). If required, replace the valve.
- Inspect and if required, replace the anode.

If the anode is not replaced, it should be replaced within three years of this service (refer to “**Anode Inspection and Replacement**” on page 10).

- Check the electric heating units for excessive calcium build up or corrosion and replace if necessary.
- Drain and flush the water heater if required.

In commercial applications where large volumes of hot water are used, sediment may build up on the bottom of the cylinder. In extreme cases, particularly in areas of high water sediment, draining and flushing out may be necessary.

- Visually check the unit for any potential problems.
- Inspect all connections.
- Check the drain line from the safe tray (if one is installed) is not blocked.

Note: The water heater may need to be drained during this service. After the completion of the service, the water heater will take some time to reheat the water. Depending upon the power supply connection, hot water may not be available until the next day.

TEMPERATURE PRESSURE RELIEF VALVE

This valve is near the top of the water heater and is essential for its safe operation. It is possible for the valve to release a little water through the drain line during each heating period. This occurs as the water is heated and expands by approximately 1/50 of its volume.

Continuous leakage of water from the valve and its drain line may indicate a problem with the water heater (refer to **“Temperature Pressure Relief Valve Running”** on page 13).

⚠ Warning: Never block the outlet of this valve or its drain line for any reason.

Operate the easing lever on the temperature pressure relief valve once every six months. **It is very important you raise and lower the lever gently.**

⚠ DANGER: Failure to do this may result in the water heater cylinder failing, or under certain circumstances, exploding.

⚠ Warning: Exercise care to avoid any splashing of water, as water discharged from the drain line will be hot. Stand clear of the drain line’s point of discharge when operating the valve’s lever.

If water does not flow freely from the drain line when the lever is lifted, then the water heater must be checked. Phone Rheem Service or their nearest Accredited Service Agent to arrange for an inspection.

The temperature pressure relief valve should be replaced at intervals not exceeding 5 years, or more frequently in areas where there is a high incidence of water deposits (refer to **“Water Supplies”** on page 9).

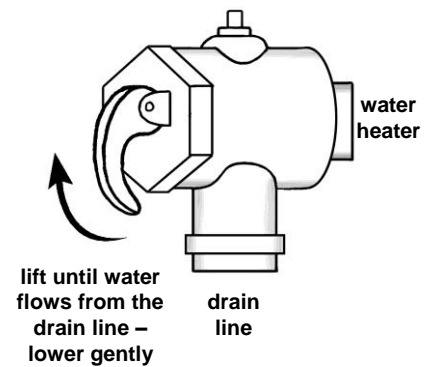
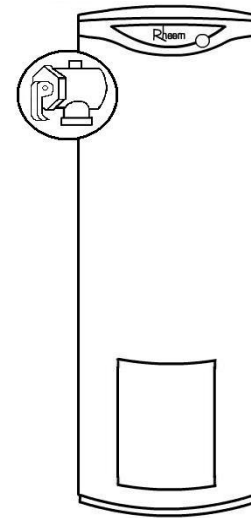

EXPANSION CONTROL VALVE

In many areas, including South Australia, Western Australia and scaling water areas, an expansion control valve is fitted to the cold water line to the water heater. The expansion control valve may discharge a small quantity of water from its drain line during the heating period instead of the temperature pressure relief valve on the water heater.

Operate the easing lever on the expansion control valve once every six months. **It is very important you raise and lower the lever gently.** The expansion control valve should be checked for performance or replaced at intervals not exceeding 5 years, or more frequently in areas where there is a high incidence of water deposits.

WATER SUPPLIES

This water heater must be installed in accordance with this advice to be covered by the Rheem warranty.

This water heater is manufactured to suit the water conditions of most public reticulated water supplies. However, there are some known water chemistries which can have detrimental effects on the water heater and its operation and / or life expectancy. If you are unsure of your water chemistry, you may be able to obtain information from your local water supply authority. This water heater should only be connected to a water supply which complies with these guidelines for the Rheem warranty to apply.

CHANGE OF WATER SUPPLY

The changing or alternating from one water supply to another can have a detrimental effect on the operation and / or life expectation of a water heater cylinder, a temperature pressure relief valve and a heating unit.

Where there is a changeover from one water supply to another, e.g. a rainwater tank supply, bore water supply, desalinated water supply, public reticulated water supply or water brought in from another supply, then water chemistry information should be sought from the supplier or it should be tested to ensure the water supply meets the requirements given in these guidelines for the Rheem warranty to apply.

ANODE

The vitreous enamel lined cylinder of the water heater is only covered by the Rheem warranty when the total dissolved solids (TDS) content in the water is less than 2500 mg/L and when the correct colour coded anode is used. If an incorrect colour coded anode is used in the water heater, any resultant faults will not be covered by the Rheem warranty. In addition, the use of an incorrect colour coded anode may shorten the life of the water heater cylinder.

The correct colour coded anode must be selected and fitted to the water heater in accordance with the following advice and the **Anode Selection chart** on page 9 for the Rheem warranty to apply to the water heater cylinder.

| Total Dissolved Solids | Anode colour code |
|------------------------|-----------------------------|
| 0 – 40 mg/L | Green |
| 40 – 150 mg/L | Green or Black |
| 150 – 400 mg/L | Black |
| 400 – 600 mg/L | Black or Blue |
| 600 – 2500 mg/L | Blue |
| 2500 mg/L + | Blue (no cylinder warranty) |

The changing of anodes must be carried out by a qualified person.

Note: Some water analysis reports may state the conductivity of the water rather than the level of total dissolved solids. Conductivity, measured in microsiemens per centimetre ($\mu\text{S} / \text{cm}$), is directly proportional to the TDS content of the water. TDS, in mg / L, is approximately 70% of the conductivity in $\mu\text{S} / \text{cm}$.

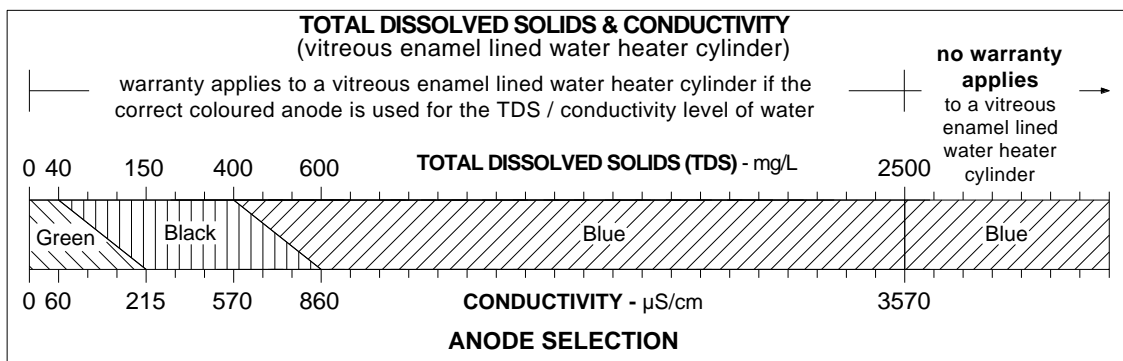

ANODE INSPECTION AND REPLACEMENT

The anode installed in your water heater will slowly dissipate whilst protecting the cylinder. The life of the cylinder may be extended by replacing the anode.

If the anode is not replaced during a five year service (refer to **“Major Five Year Service”** on page 7) then the maximum time after installation when the anode should be replaced for this electric water heater is 8 years.

For water supplies which are either softened, desalinated or where the water supply may alternate between a water tank and a reticulated public supply or another supply, it is recommended the anode be replaced within 5 years of installation.

CAUTION

If the water supply has a TDS greater than 150 mg/L and a green anode has not been changed to a black anode, or if the TDS is greater than 600 mg/L and the anode has not been changed to a blue anode, there is the possibility the anode may become overactive and hydrogen gas could accumulate in the top of the water heater during long periods of no use.

If, under these conditions, the water heater has not been used for two or more weeks the following procedure should be carried out before using any electrical appliances (automatic washing machines and dishwashers) which are connected to the hot water supply.

The hydrogen, which is highly flammable, should be vented safely by opening a hot tap and allowing the water to flow. There should be no smoking or naked flame near the tap whilst it is turned on. Any hydrogen gas will be dissipated. This is indicated by an unusual spurting of the water from the tap. Once the water runs freely, any hydrogen in the system will have been released.

SATURATION INDEX

The saturation index is used as a measure of the water’s corrosive or scaling properties.

In a corrosive water supply, the water can attack copper parts and cause them to fail.

Where the saturation index is less than -1.0 , the water is very corrosive and the Rheem warranty does not apply to a copper sheathed heating unit. A corrosion resistant heating unit must be used for the Rheem warranty to apply to the heating unit.

In a scaling water supply calcium carbonate is deposited out of the water onto any hot metallic surface.

Where the saturation index exceeds $+0.40$, the water is very scaling. An expansion control valve must be fitted on the cold water line after the non-return valve to protect and for the Rheem warranty to apply to the temperature pressure relief valve and water heater cylinder.

Where the saturation index exceeds $+0.80$, the Rheem warranty does not apply to a standard watts density heating unit. A low watts density heating unit must be used for the Rheem warranty to apply to the heating unit.

Water which is scaling may be treated with a water softening device to reduce the saturation index of the water.

Contact Rheem Service or their nearest Accredited Service Agent if a replacement heating unit is required.

Refer to the **Saturation Index chart** on page 11.

Refer to the **cold water connection detail on page 20** for the position of the expansion control valve.

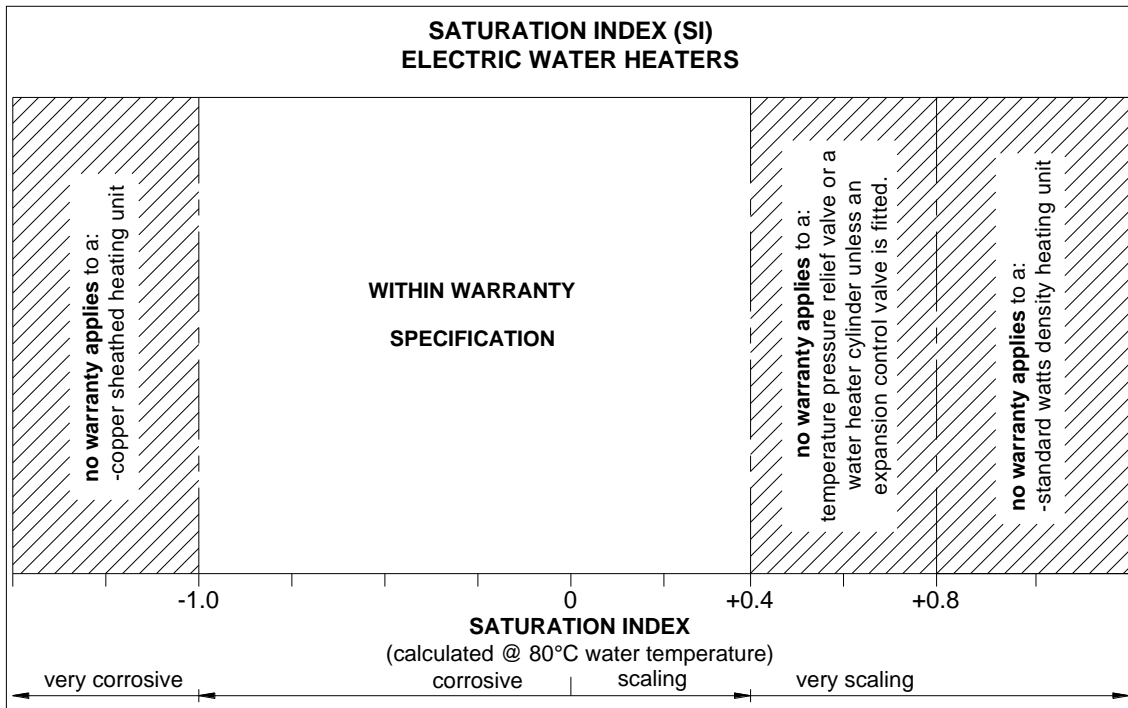

SUMMARY OF WATER CHEMISTRY ADVICE AFFECTING WARRANTY

The water heater and its components are not suitable for certain water chemistries. Those chemistries are listed below. If the water heater is connected at any time to a water supply with the following water chemistry, the Rheem warranty will not cover any resultant faults on the components listed below:

| Water Chemistry | Component |
|--|--|
| Total Dissolved Solids (TDS) > 2500 mg/L | water heater cylinder |
| Total Dissolved Solids (TDS) not suitable for anode type | water heater cylinder |
| Saturation Index (SI) < -1.0 | copper sheathed heating unit |
| Saturation Index (SI) > +0.4 (if expansion control valve is not fitted) | water heater cylinder temperature pressure relief valve |
| Saturation Index (SI) > +0.8 | standard watts density heating unit |

SAVE A SERVICE CALL

Check the items below before making a service call. You will be charged for attending to any condition or fault that is not related to manufacture or failure of a part.

NOT ENOUGH HOT WATER (OR NO HOT WATER)

- **Is the electricity switched on?**

Inspect the isolating switch marked "HOT WATER" or "WATER HEATER" at the switchboard and the isolating switch (if one is installed) near the water heater and ensure they are turned on.

Note: Check the electricity supply to which the water heater is connected. If on a time controlled electricity supply, remember heating hours are restricted.

Check the fuse marked "HOT WATER" or "WATER HEATER" at the switchboard.



- **Are you using more hot water than you think?**

Are outlets (especially the showers) using more hot water than you think? Very often it is not realised the amount of hot water used, particularly when showering.

Carefully review the hot water usage. Have your plumber fit a flow control valve to each shower outlet to reduce water usage.

- **Temperature pressure relief valve running**

Is the relief valve discharging too much water?

(Refer to "[Temperature Pressure Relief Valve Running](#)" on page 13).

- **Thermostat setting**

Ensure the thermostat setting is appropriate. You may choose to have your electrician adjust the thermostats upwards to gain additional hot water capacity.

⚠ Warning: Hotter water increases the risk of scald injury.

- **Water heater size**

Do you have the correct size water heater for your requirements?

The sizing guide in the Rheem sales literature and on the Rheem website (www.rheem.com.au) suggests average sizes that may be needed.

TEMPERATURE PRESSURE RELIEF VALVE RUNNING

- **Normal Operation**

It is normal and desirable that this valve allows a small quantity of water to escape during the heating cycle. However, if the discharge is deemed excessive (more than 2% of hot water used), there may be another problem.

- **Continuous dribble**

Try gently raising the easing lever on the relief valve for a few seconds (refer to **“Temperature Pressure Relief Valve”** on page 8). This may dislodge a small particle of foreign matter and clear the fault. Release the lever gently.

- **Steady flows for long period (often at night)**

This may indicate the mains water pressure sometimes rises above the designed pressure of the water heater. Ask your installing plumber to fit a pressure limiting valve.

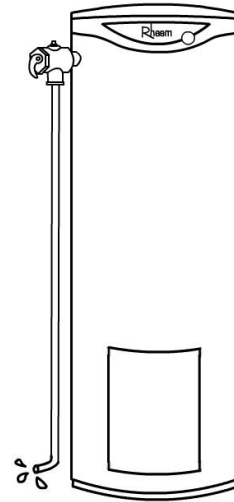

⚠ Warning: Never replace the relief valve with one of a higher pressure rating.

- **Heavy flows of hot water until water heater is cold - then stops until water reheats**

The water heater **must** be switched off at the switchboard. Phone Rheem Service or their nearest Accredited Service Agent to arrange for inspection.

EXPANSION CONTROL VALVE RUNNING

If an expansion control valve is fitted in the cold water line to the water heater (refer to page 20) it may discharge a small quantity of water instead of the temperature pressure relief valve on the water heater. The benefit is that energy is conserved as the discharged water is cooler.

HIGHER THAN EXPECTED ELECTRICITY BILLS

Should you at any time, feel your electricity account is higher than expected, we suggest you check the following points:

- Is the relief valve running excessively?

Refer to **“Temperature Pressure Relief Valve Running”** on page 13.

- Are outlets (especially the showers) using more hot water than you think?

Refer to **“Not Enough Hot Water”** on page 12.

- Is there a leaking hot water pipe, dripping hot water tap, etc?

Even a small leak will waste a surprising quantity of hot water and electricity. Replace faulty tap washers, and have your plumber rectify any leaking pipe work.

- Has there been an increase in hot water usage?

An increase in hot water usage will result in an increase in water heater operation.

- Has your water heating tariff rate been increased by your electricity retailer since your previous account?

- The electricity tariff to which your water heater is connected will determine the overall operating cost of the system.

It is important you are aware of this tariff, i.e. continuous or time controlled supply.

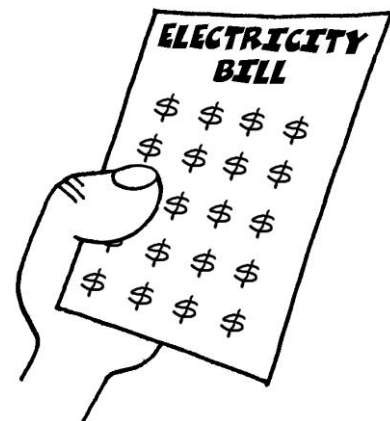

IF YOU HAVE CHECKED ALL THE FOREGOING AND STILL BELIEVE YOU NEED ASSISTANCE, PHONE RHEEM SERVICE OR THEIR NEAREST ACCREDITED SERVICE AGENT.

INSTALLATION

THIS WATER HEATER IS NOT SUITABLE FOR POOL HEATING

INSTALLATION STANDARDS

The water heater must be installed:

- by a qualified person, and
- in accordance with the installation instructions, and
- in compliance with Standards AS/NZS 3500.4, AS/NZS 3000 and all local codes and regulatory authority requirements.

In New Zealand the installation must also conform with the New Zealand Building Code.

All packaging materials must be removed from the water heater prior to its installation. This includes the removal of the cardboard base of the carton from the underside of the water heater.

WATER HEATER APPLICATION

This water heater is designed for the purpose of heating potable water. Its use in an application other than this may shorten its life.

If this water heater is to be used where an uninterrupted hot water supply is necessary for the application or business, then there should be redundancy within the hot water system design. This should ensure the continuity of hot water supply in the event that this water heater was to become inoperable for any reason. We recommend you provide advice to the system owner about their needs and building backup redundancy into the hot water supply system.

Note: AS 3498 requires that a water heater provides the means to inhibit the growth of Legionella bacteria in potable water. This water heater can satisfy this AS 3498 requirement provided it is energised and the thermostat setting is 60°C or higher, including when it is used as an in-series booster water heater for a solar water heater.

WATER HEATER LOCATION

This water heater is suitable for either outdoor or indoor installation. Whether located outdoor or indoor, the water heater should be installed either close to the most frequently used outlets or with a circulated flow and return system and its position chosen with safety and service in mind.

Clearance must be allowed for servicing of the water heater. The water heater must be accessible without the use of a ladder or scaffold. Make sure the temperature pressure relief valve lever is accessible and the front cover, thermostats and heating units can be removed for service. You must be able to read the information on the rating plate. If possible leave headroom of one water heater height so the anode can be inspected or replaced. Remember you may have to take the entire water heater out later for servicing.

It is recommended the water heater be installed at ground or floor level and must stand vertically upright. The base of the water heater is made of corrosion resistant material, and it may be placed directly in contact with the supporting surface. It is not necessary to allow for free air circulation under the base of the water heater.

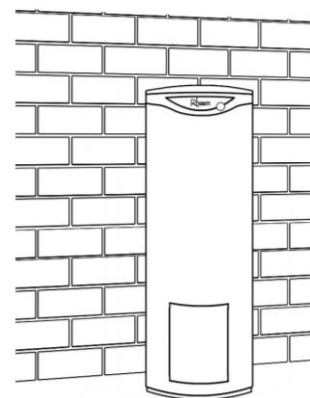

Note: The water heater should not be placed in direct contact with a concrete surface that is less than two months old and not fully cured as this may attack the metal coating of the water heater base. A moisture barrier should be used between the two surfaces in this instance.

Remember all local authorities have regulations about putting water heaters into roof spaces.

For a single water heater installation, follow the [diagram on page 19](#). For multiple water heater installations, follow the [instructions on pages 24 to 27](#).

SAFE TRAY

Where damage to property can occur in the event of the water heater leaking, the water heater must be installed in a safe tray. Construction, installation and draining of a safe tray must comply with AS/NZS 3500.4 and all local codes and regulatory authority requirements. AS/NZS 3500.4 also has particular requirements when a safe tray must be installed.

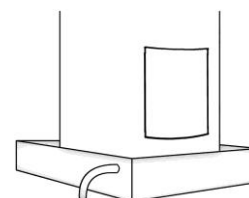

MAINS WATER SUPPLY

Where the mains water supply pressure exceeds that shown in the table below, an approved pressure limiting valve is required and should be fitted as shown in the installation diagram (refer to installation diagram on page 20).

| Model | 050, 315 |
|----------------------------------|----------|
| Relief valve setting | 1000kPa |
| Expansion control valve setting* | 850kPa |
| Max. mains supply pressure | |
| With expansion control valve | 680kPa |
| Without expansion control valve | 800kPa |

* Expansion control valve not supplied with water heater

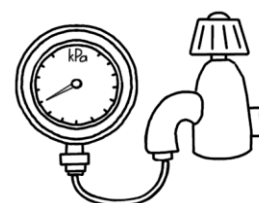

TANK WATER SUPPLY

If the water heater is supplied with water from a tank supply and a pressure pump system is not installed, then the bottom of the supply tank must be at least 1 m above the highest point of the hot water plumbing system, including the water heater. Care must be taken to avoid air locks. The cold water line to the water heater should be adequately sized and fitted with a full flow gate valve or ball valve.

HOT WATER DELIVERY

This water heater can deliver water at temperatures which can cause scalding.

It is necessary and we recommend that a temperature limiting device be fitted between the water heater and the hot water outlets in any ablution and public areas such as bathrooms, ensuites or public amenities, to reduce the risk of scalding. The installing plumber may have a legal obligation to ensure the installation of this water heater meets the delivery water temperature requirements of AS/NZS 3500.4 so that scalding water temperatures are not delivered to a bathroom, ensuite, or other ablution or public area.

Where a temperature limiting device is installed adjacent to the water heater, the cold water line to the temperature limiting device can be branched off the cold water line either before or after the isolation valve, pressure limiting and non return valve to the water heater. If an expansion control valve is required, it must always be installed after the non return valve and be the last valve prior to the water heater.

If a pressure limiting valve is installed on the cold water line to the water heater and the cold water line to a temperature limiting device branches off before this valve or from another cold water line in the premises, then a pressure limiting valve of an equal pressure setting may be required prior to the temperature limiting device.

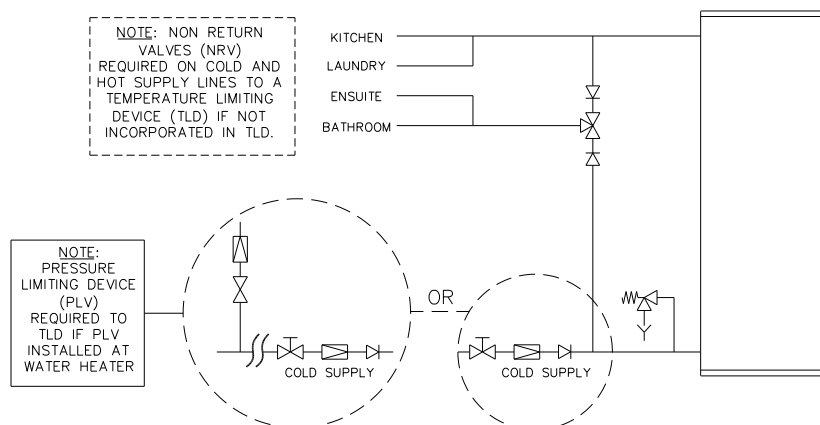

Two Temperature Zones Using a Temperature Limiting Device

CIRCULATED HOT WATER FLOW AND RETURN SYSTEM

If a Rheem water heater is to be installed as part of a circulated hot water flow and return system, a storage water heater able to provide a hot water outlet temperature of at least 60°C must be used. **Note:** The thermostat must always be set to at least 60°C. Refer to the [diagram on page 16](#).

Temperature Limiting Device

A temperature limiting device cannot be installed in circulated hot water flow and return pipe work unless it is specifically designed to do so, such as the Rheem Guardian warm water system.

The tempered water from a temperature limiting device cannot be circulated. Where a circulated hot water flow and return system is required in a building, a temperature limiting device can only be installed on a dead leg, branching off the circulated hot water flow and return pipe.

If circulated tempered water were to be returned back to the water heater, depending on the location of the return line connection on the water supply line to the water heater, then either:

- water will be supplied to the cold water inlet of the temperature limiting device at a temperature exceeding the maximum recommended water supply temperature, or
- when the hot taps are closed no water will be supplied to the cold water inlet of the temperature limiting device whilst hot water will continue to be supplied to the hot water inlet of the temperature limiting device.

These conditions may result in either water at a temperature exceeding the requirements of AS/NZS 3500.4 being delivered to the hot water outlets in the ablution areas, or the device closing completely and not delivering water at all, or the device failing. Under either condition, the operation and performance of the device cannot be guaranteed.

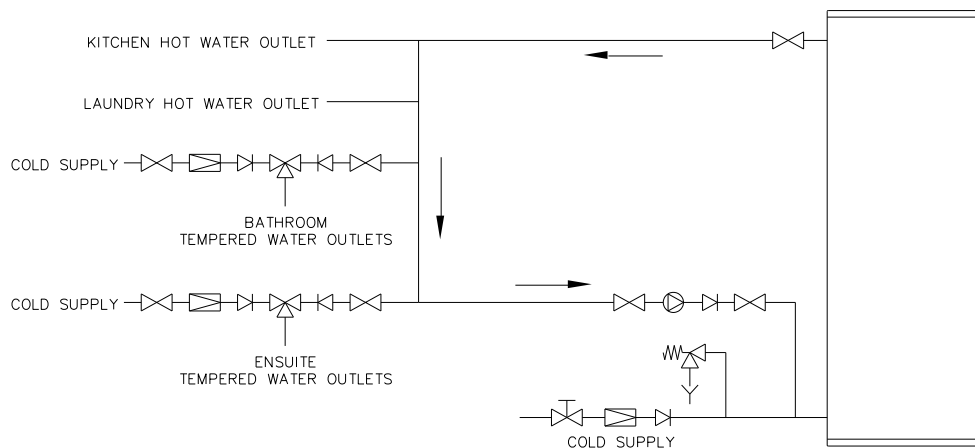

Circulated Hot Water Flow and Return System – Continuous Electric Water Heater

REDUCING HEAT LOSSES

The cold water line to and the hot water line from the water heater must be insulated in accordance with the requirements of AS/NZS 3500.4. The insulation must be weatherproof and UV resistant if exposed.

Keep temperature settings down. Lower temperatures reduce heat losses and prolong cylinder life. Do not set the controlling thermostats above 70°C unless it is necessary.

BOOSTER WATER HEATER INSTALLATION

It can be advantageous to plumb the Heavy Duty electric water heater as a booster water heater in some cases. In this type of installation, the water heater is plumbed into a hot water circuit, with hot water being supplied to the inlet of the water heater. The hot water is then boosted to a temperature of up to 82°C. It may be necessary to achieve sanitising temperatures when required by regulations for certain applications. Isolation valves are required on the inlet line to and the outlet line from the water heater.

Refer to **“Safe Tray”** on page 15.

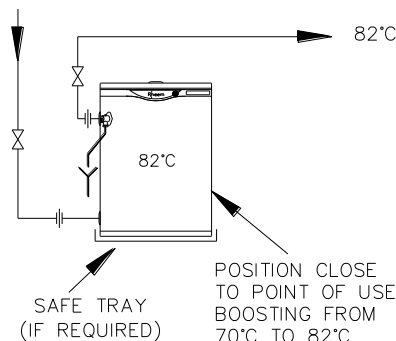

ANODE

The vitreous enamel lined cylinder of the water heater is only covered by the Rheem warranty when the total dissolved solids (TDS) content in the water is less than 2500 mg/L and when the correct colour coded anode is used. If an incorrect colour coded anode is used in the water heater, any resultant faults will not be covered by the Rheem warranty. In addition, the use of an incorrect colour coded anode may shorten the life of the water heater cylinder.

The correct colour coded anode for the water supply being used must be selected and fitted to the water heater for the Rheem warranty to apply to the water heater cylinder (refer to **“Water Supplies”** on page 9 and the **Anode Selection chart** on page 9). The black anode is typically fitted as standard.

| Total Dissolved Solids | Anode colour code |
|------------------------|-----------------------------|
| 0 – 40 mg/L | Green |
| 40 – 150 mg/L | Green or Black |
| 150 – 400 mg/L | Black |
| 400 – 600 mg/L | Black or Blue |
| 600 – 2500 mg/L | Blue |
| 2500 mg/L + | Blue (no cylinder warranty) |

If the water supply has a TDS greater than 150 mg/L and a green anode has not been changed to a black anode, or if the TDS is greater than 600 mg/L and the anode has not been changed to a blue anode, there is the possibility the anode may become overactive and hydrogen gas could accumulate in the top of the water heater during long periods of no use. In areas where this is likely to occur, the installer should instruct the householder on how to dissipate the gas safely (refer to **“Caution”** on page 10).

SADDLING PIPE WORK

To prevent damage to the cylinder when attaching pipe clips or saddles to the water heater jacket, we recommend the use of self drilling screws with a maximum length of 13 mm. Should pre drilling be required, extreme caution must be observed when penetrating the jacket of the water heater.

Note: If the cylinder is damaged as a result of attaching pipe clips or saddles to the jacket, any resultant faults will not be covered by the Rheem warranty.

DIMENSIONS AND TECHNICAL DATA

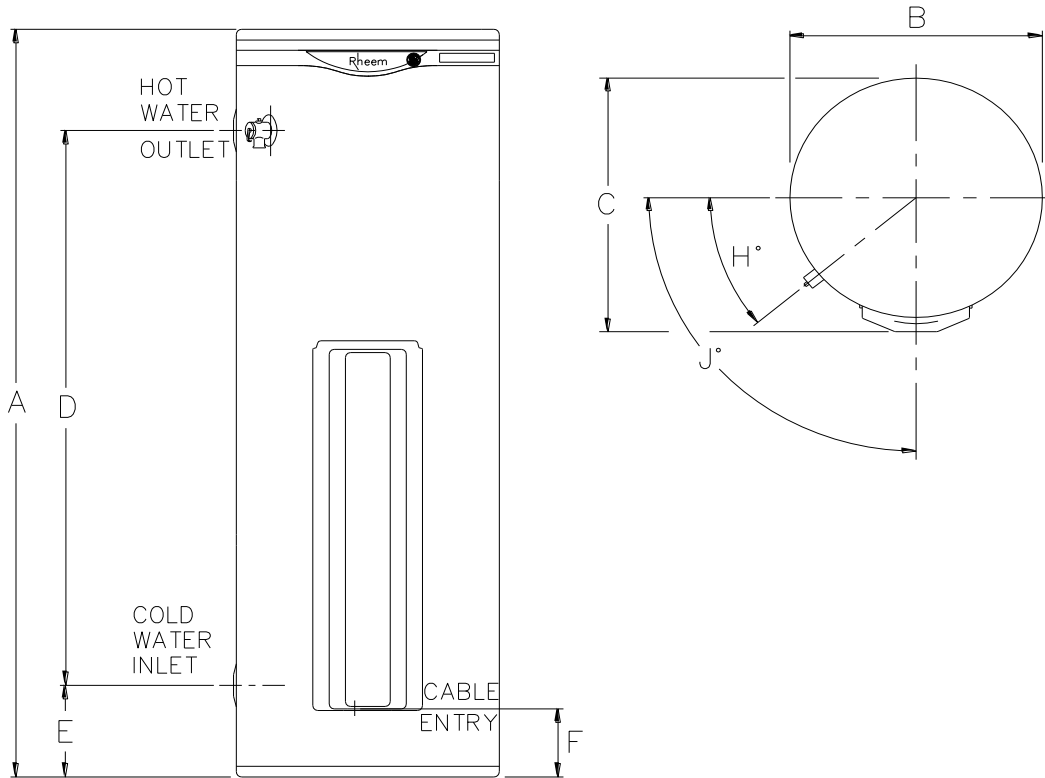

| Model | | | 613 050 | 613 315 | 616 315 |
|------------------------------|--------|---------|---------|---------|---------|
| Heating Units | No. | | 3 | 3 | 6 |
| Hot Water Delivery | litres | | 50 | 315 | 315 |
| Thermostat Setting - Factory | °C | | 75 | 75 | 75 |
| Thermostat Setting - Maximum | °C | | 82 | 82 | 82 |
| Nominal Dimensions (mm) | A | mm | 675 | 1640 | 1640 |
| | B | mm | 440 | 640 | 640 |
| | C | mm | 480 | 680 | 680 |
| | D | mm | 405 | 1294 | 1294 |
| | E | mm | 90 | 128 | 128 |
| | F | mm | 80 | 130 | 130 |
| | J | degrees | 90 | 90 | 90 |
| Weight | empty | kg | 34 | 100 | 104 |
| | full | kg | 94 | 425 | 429 |

Technical data is subject to change.

TYPICAL INSTALLATION – OUTDOOR LOCATION

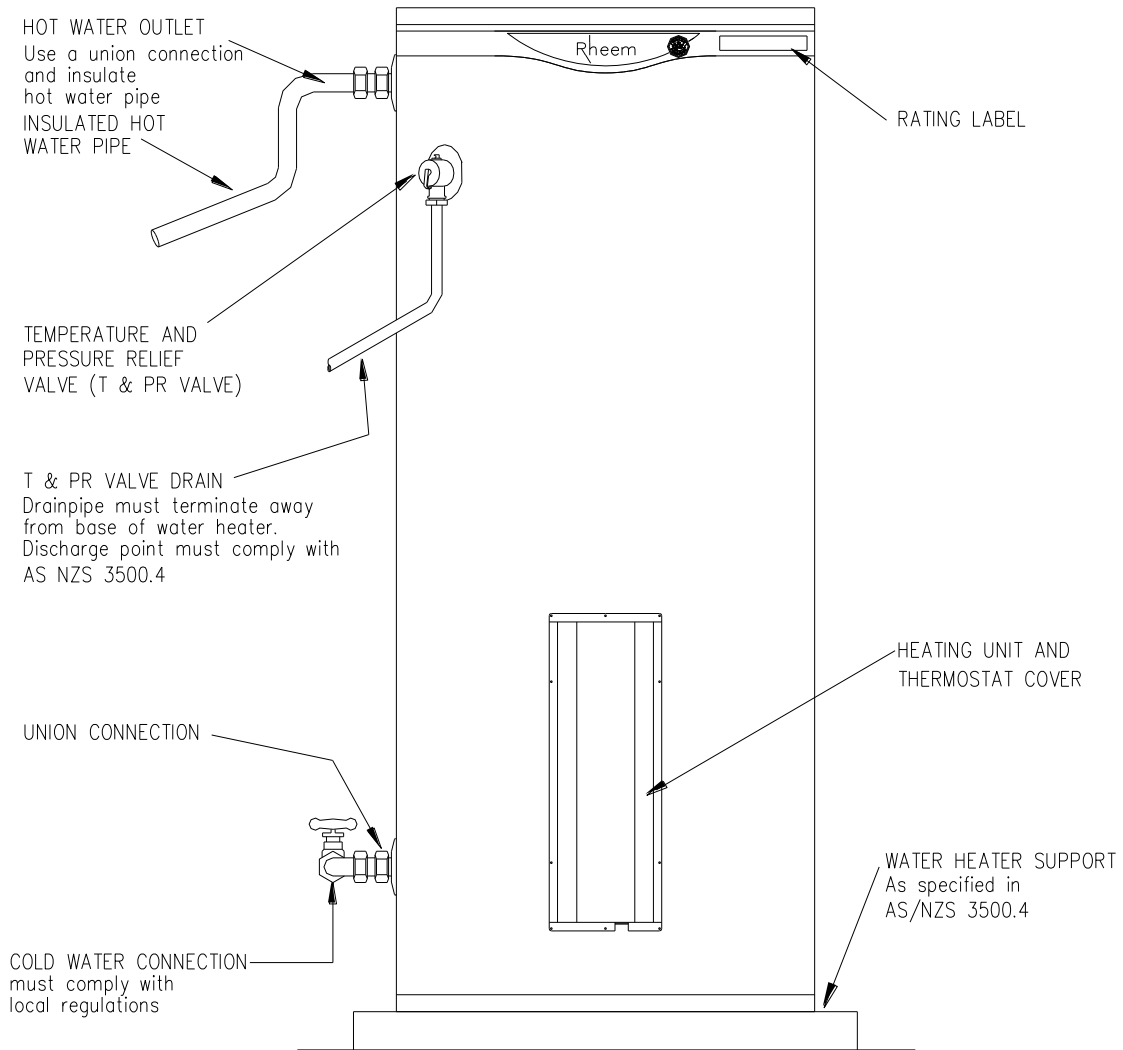

TYPICAL INSTALLATION – INDOOR LOCATION

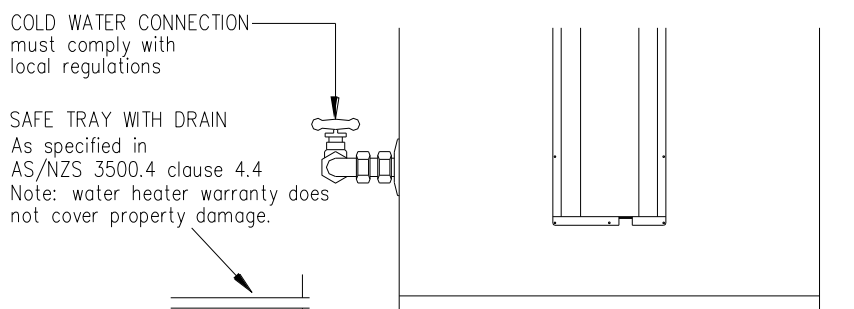

CONNECTIONS – PLUMBING

All plumbing work must be carried out by a qualified person and in accordance with the Standard AS/NZS 3500.4 and all local codes and regulatory authority requirements. In New Zealand the installation must also conform with the New Zealand Building Code.

CONNECTION SIZES

- Hot water connection: RP 1¼/32.
- Cold water connection: RP 1¼/32.
- Relief valve connection: RP ¾/20.

WATER INLET AND OUTLET

All pipe work must be cleared of foreign matter before connection and purged before attempting to operate the water heater. All olive compression fittings must use brass or copper olives. Use thread sealing tape or approved thread sealant on all fittings.

An isolation valve and non-return valve must be installed on the cold water line to the water heater. An acceptable arrangement is shown in the diagram [or on page 26](#) for multiple installations. Refer also to [“Hot Water Delivery”](#) on page 15.

A disconnection union must always be provided at the cold water inlet and hot water outlet on the water heater to allow for disconnection of the water heater.

This water heater has either a plastic dip tube or fitting liner in the inlet and outlet fittings (see diagram). These must be in place for the water heater to function properly. Do not remove or damage them by using heat nearby. They will be pushed into the correct position as the fitting is screwed in.

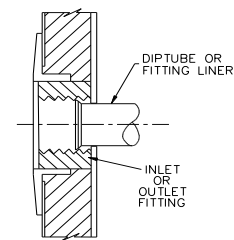
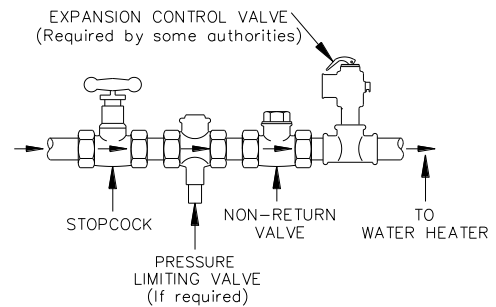

PIPE SIZES

The pipe sizing for hot water supply systems should be carried out by persons competent to do so, choosing the most suitable pipe size for each individual application. Reference to the technical specifications of the water heater and local regulatory authority requirements must be made.

TEMPERATURE PRESSURE RELIEF VALVE

The temperature pressure relief valve is shipped either under the top flap of the water heater carton or behind the front cover or in a plastic bag attached to the water heater. The temperature pressure relief valve must be fitted before the water heater is operated. Before fitting the relief valve, make sure the probe has not been bent. Seal the thread with Teflon tape - never hemp. Make sure the tape does not hang over the end of the thread.

Screw the valve into the correct opening ([refer to the installation diagram on page 19](#)) leaving the valve drain pointing downwards. Do not use a wrench on the valve body - use the spanner flats provided. A copper drain line must be fitted to the temperature pressure relief valve ([refer to "Relief Valve Drain" on page 21](#)).

The valve must be insulated with closed cell polymer insulation or similar (minimum thickness 9 mm) and the insulation installed so as not to impede the operation of the valve. The insulation must be weatherproof and UV resistant if exposed.

EXPANSION CONTROL VALVE

Local regulations may make it mandatory to install an expansion control valve (ECV) in the cold water line to the water heater. In other areas, an ECV is required if the saturation index is greater than +0.4 (refer to "Water Supplies" on page 9).

The expansion control valve must always be installed after the non return valve and be the last valve installed prior to the water heater (refer to diagram on page 20). A copper drain line must be fitted to the expansion control valve (refer to "Relief Valve Drain" on page 21).

The valve must be insulated with closed cell polymer insulation or similar (minimum thickness 9 mm) and the insulation installed so as not to impede the operation of the valve. The insulation must be weatherproof and UV resistant if exposed.

RELIEF VALVE DRAIN

DN20 copper drain lines must be fitted to the temperature pressure relief valve and expansion control valve (if one is installed) to carry the discharge clear of the water heater. Connect the drain lines to the valves using disconnection unions. The drain line from the valve to the point of discharge should be as short as possible, have a continuous fall all the way from the water heater to the discharge outlet and have no tap, valves or other restrictions in the pipe work. A drain line from a relief valve must comply with the requirements of AS/NZS 3500.4.

A drain line must be no longer than 9 metres with no more than three bends greater than 45° before discharging at an outlet or air break. The maximum length of 9 metres for a drain line is reduced by 1 metre for each additional bend required of greater than 45°, up to a maximum of three additional bends. Where the distance to the point of final discharge exceeds this length, the drain line can discharge into a tundish.

Subject to local regulatory authority approval, the drain lines from the temperature pressure relief valve and expansion control valve from an individual water heater may be interconnected.

The outlet of a drain line must be in such a position that flow out of the pipe can be easily seen, but arranged so discharge will not cause injury, damage or nuisance. The termination point of a drain line must comply with the requirements of AS/NZS 3500.4. Drain lines must not discharge into a safe tray.

In locations where water pipes are prone to freezing, drain lines must be insulated, must not exceed 300 mm in length and are to discharge into a tundish through an air gap of between 75 mm and 150 mm.

If a drain line discharges into a tundish, the drain line from the tundish must be not less than DN25. The drain line from a tundish must meet the same requirements as for a drain line from a relief valve.

For multiple installations the drain lines from several water heaters can discharge into a common tundish (refer to "Multiple Installations" on pages 24 and 25).

⚠ Warning: As the function of the temperature pressure relief valve on this water heater is to discharge high temperature water under certain conditions, it is strongly recommended the pipe work downstream of the relief valve be capable of carrying water exceeding 93°C. Failure to observe this precaution may result in damage to pipe work and property.

CONNECTIONS – ELECTRICAL

The power supply to the water heater must not be switched on until the water heater is filled with water and a satisfactory megger reading is obtained.

All electrical work and permanent wiring must be carried out by a qualified person and in accordance with the Wiring Rules AS/NZS 3000 and all local codes and regulatory authority requirements.

Note: AS 3498 requires that a water heater provides the means to inhibit the growth of Legionella bacteria in potable water. This water heater can satisfy this AS 3498 requirement provided it is energised and the thermostat setting is 60°C or higher, including when it is used as an in-series booster water heater for a solar water heater.

WATER HEATER

The water heater must be directly connected to either a 240V AC 50 Hz mains power supply or a 3 phase, 415 Volt AC star supply with one heating unit per phase for models with 3 heating units and two heating units per phase for models with 6 heating units. An isolating switch must be installed at the switchboard.

A 25 mm flexible conduit is required for the electrical cable to the water heater. The conduit is to be connected to the unit with a 25 mm terminator. Connect the power supply wires directly to the terminal block and earth tab connection, ensuring there are no excess wire loops inside the front cover. The temperature rating of the power supply wires insulation should suit this application.

The power rating of the heating units is shown on the rating label of the water heater and are rated for a 240 Volt power supply.

Note: The water heater is not suitable for power supplies utilising a 415 V delta connected supply.

THERMOSTAT SETTING

The thermostats are adjustable from 60°C to 82°C. The thermostat is adjusted by turning the adjuster anticlockwise to decrease the temperature setting and clockwise to increase the temperature setting. Only adjust the temperature setting when the isolating switch is switched off at the switchboard.

If this water heater is installed as an in-series booster water heater as part of a commercial solar water heating system:

- the solar control system must be of a design to limit solar contribution so the water temperature in the solar preheat tank(s) does not exceed 80°C. This is necessary to ensure the solar input does not cause the thermostat's over-temperature cut-out to operate.
- we recommend the thermostats are set at 60°C to maximise solar contribution, unless sanitising temperatures are required.

For reasons of safety and economy, we advise the thermostat is set at the lowest temperature that will provide sufficient hot water. Discuss the thermostat setting requirements with a responsible officer.

WIRING DIAGRAMS

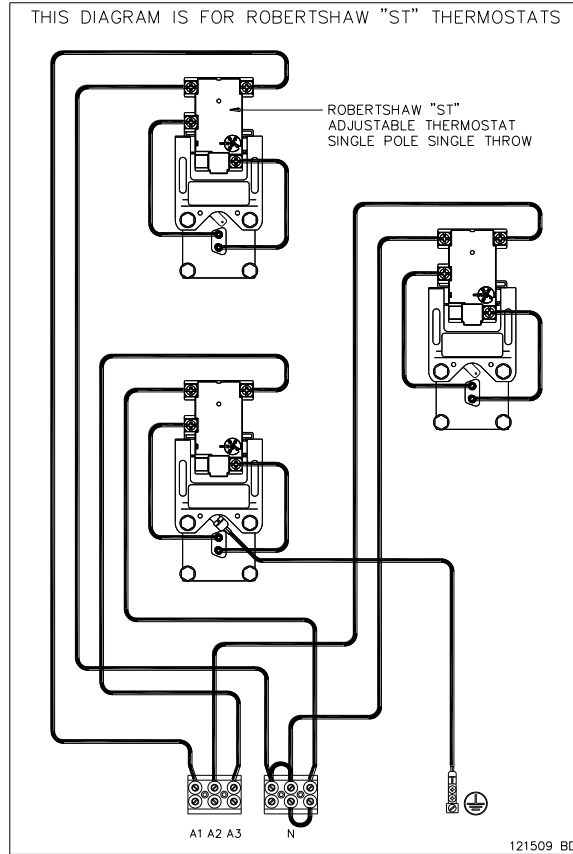

Electrical Circuit for 613 Models – Robertshaw "ST" Thermostats

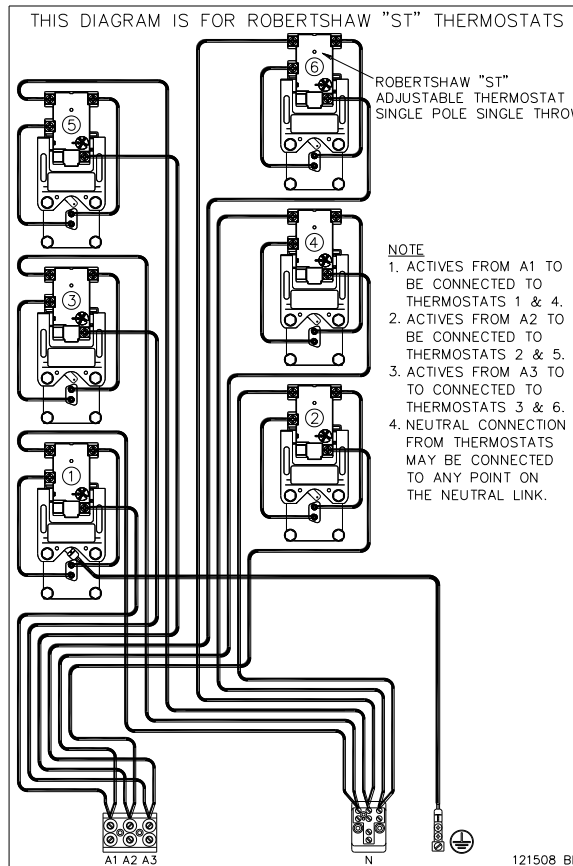

Electrical Circuit for 616 Models – Robertshaw "ST" Thermostats

MULTIPLE INSTALLATIONS

A multiple installation of Rheem water heaters on a single manifold or multiple manifolds is possible, using the Rheem Equa-Flow[®] manifold system, where large volumes of hot water is required. The Equa-Flow principle will function with water heaters in line, around a corner or in rows back to back (refer to the diagrams on page 25).

The cold water and hot water manifolds must be designed to balance the flow from each water heater. To achieve this, there are basic installation requirements and principles which must be followed:

1. The maximum number of water heaters in a bank should be 8, however several banks of water heaters can be installed.
2. The hot water line from the manifold must leave from the opposite end to which the cold water line enters the manifold.
3. The water heaters must be of the same model.
4. The cold water line, cold and hot headers and hot water line must be sized to meet the requirements of both AS/NZS 3500.4 and the application.
5. A non return valve, isolation valve and if required a pressure limiting valve and expansion control valve, must be installed on the cold water line to the system.
6. A full flow gate valve or ball valve (not a stop tap, as used on a single water heater installation) must be installed on both the cold water branch and hot water branch of each water heater.
7. Non return valves or pressure limiting valves **must not** be installed on the branch lines to the water heaters.
8. All fittings, valves and branch lines must be matched sets all the way along the manifold.
9. Sufficient space must be left to enable access, servicing or removal of any water heater.
10. The temperature pressure relief valve drain line from each water heater can terminate at a common tundish (funnel) with a visible air break at each drain discharge point (refer to the diagram on page 25 and to "Relief Drain Line" on page 21).

Refer to the diagrams on pages 25 to 27 for installation and plant layout details.

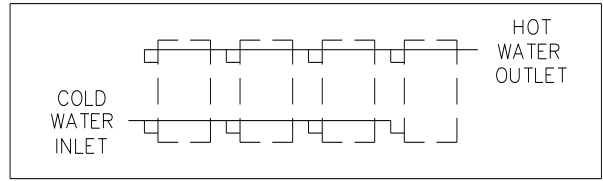
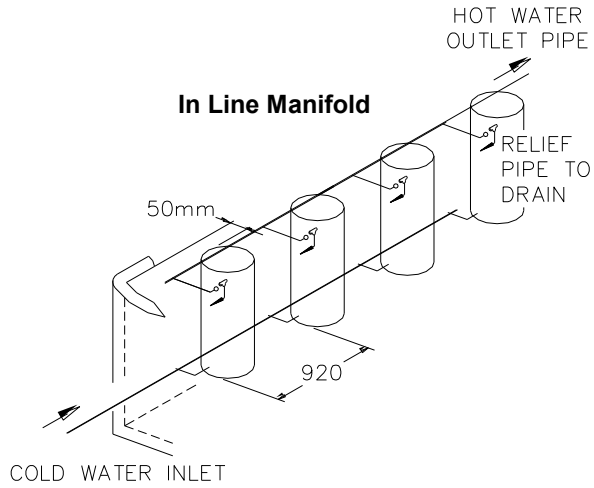

Single Bank of Water Heaters

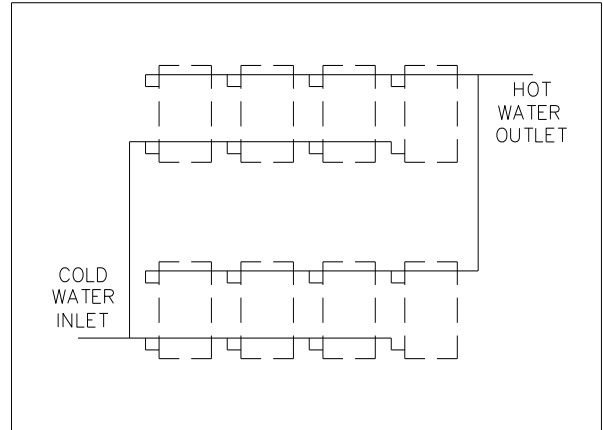
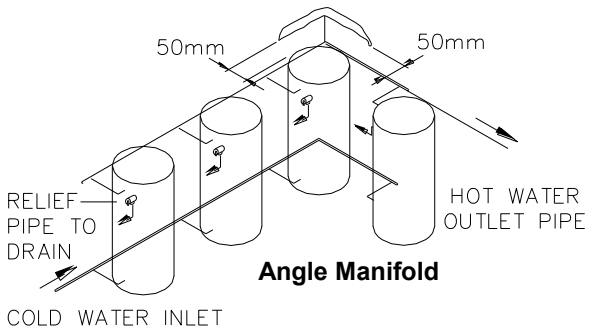

Multiple Banks of Water Heaters

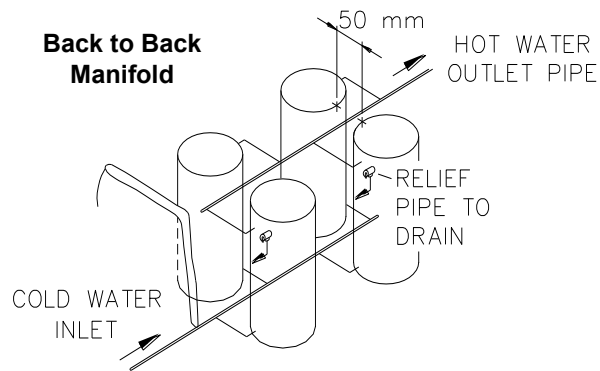

FIX ALL PIPES SECURELY IN POSITION CENTRALLY OVER TUNDISH

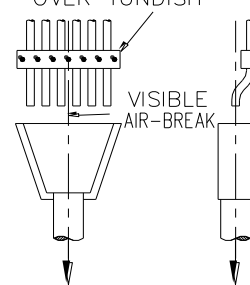

TO FINAL DISCHARGE OUTSIDE BUILDING IN ACCORDANCE WITH REQUIREMENTS OF LOCAL AUTHORITIES.

**TPR Valve Drain Line
Common Discharge Point**

TYPICAL INSTALLATION – RHEEM HEAVY DUTY ELECTRIC WATER HEATERS

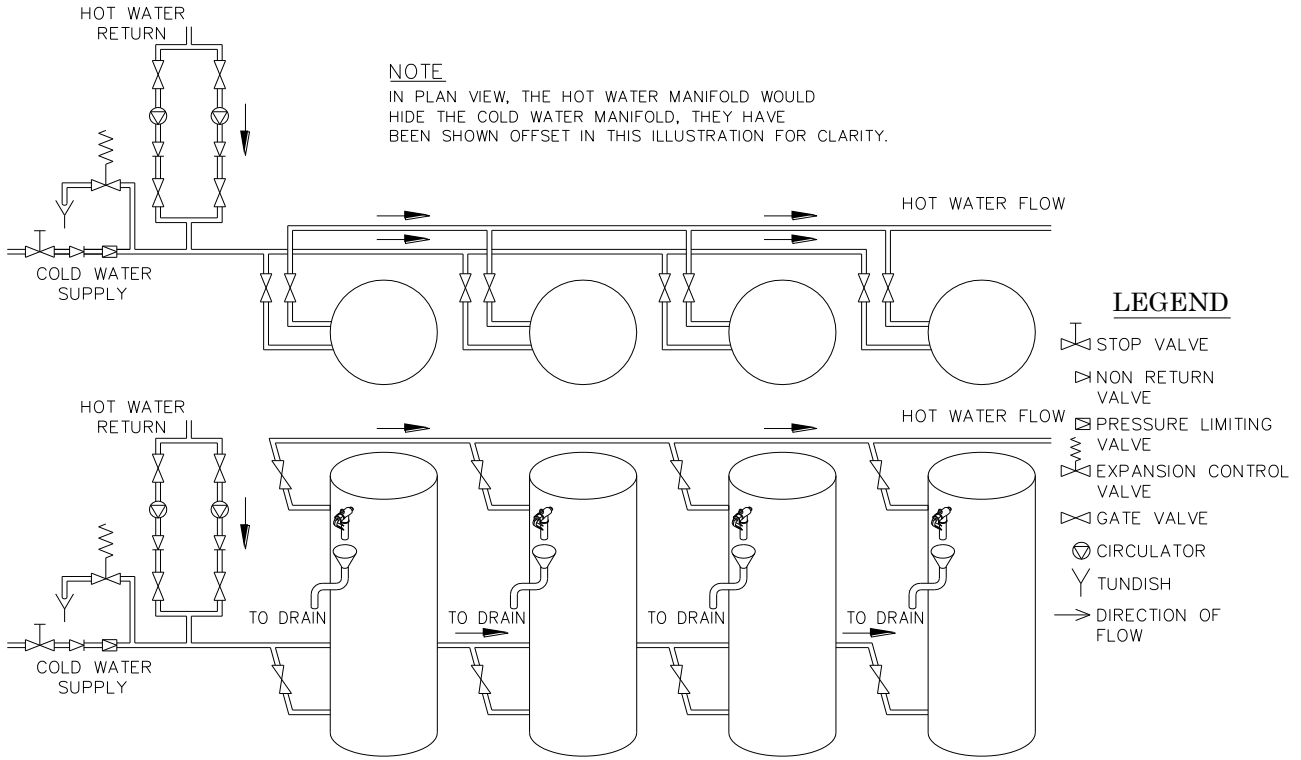

INSTALLATION DIMENSIONS – RHEEM HEAVY DUTY ELECTRIC WATER HEATERS

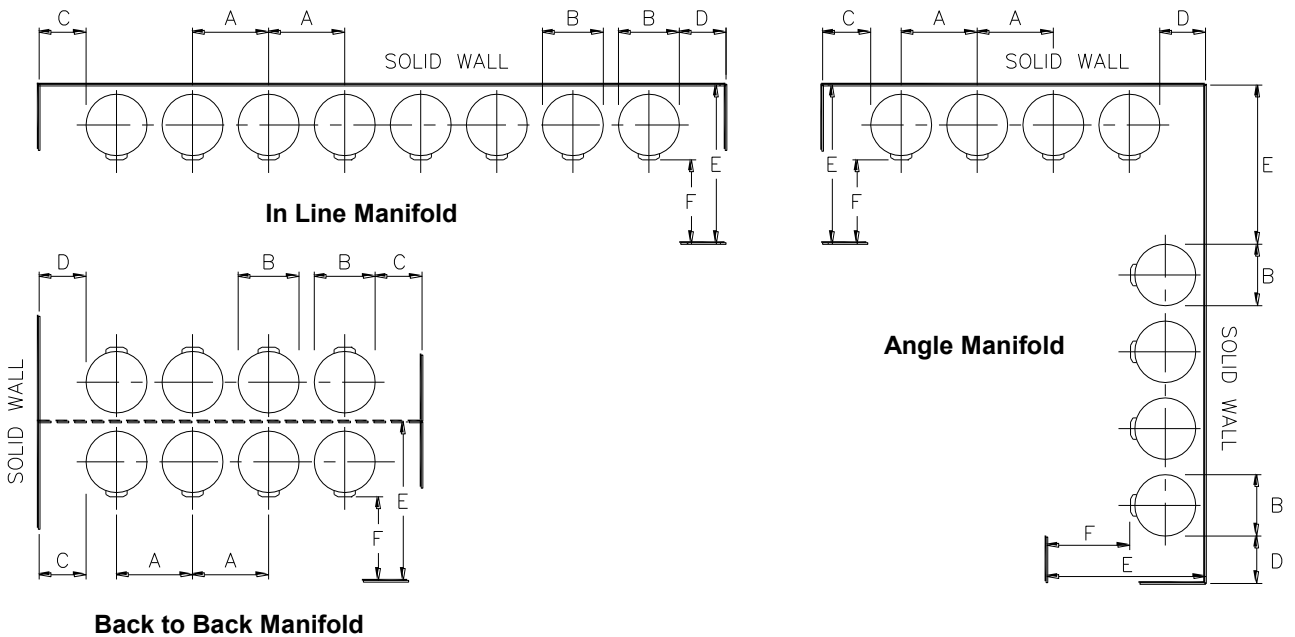

Notes

1. Minimum recommended space between wall and back of water heater is 100 mm.
2. A minimum of 900 mm (E* & F*) should be left in front of the water heater for access, servicing and water heater removal.

| Installation Layout Minimum Dimensions | | | | | | |
|--|-----|-----|-----|-----|------|-----|
| Model | A | B | C | D | E* | F* |
| 613 050 | 700 | 440 | 300 | 100 | 1480 | 900 |
| 613 315 | 900 | 640 | 300 | 100 | 1680 | 900 |
| 616 315 | 900 | 640 | 300 | 100 | 1680 | 900 |

MANIFOLD ARRANGEMENT

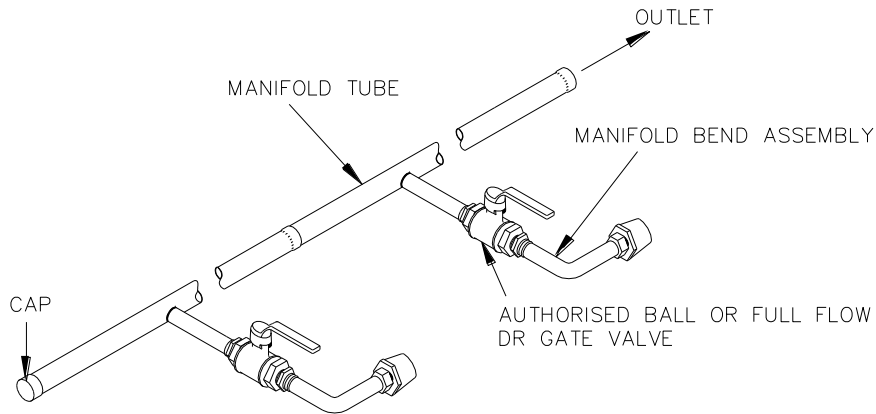

Hot Manifold Assembly

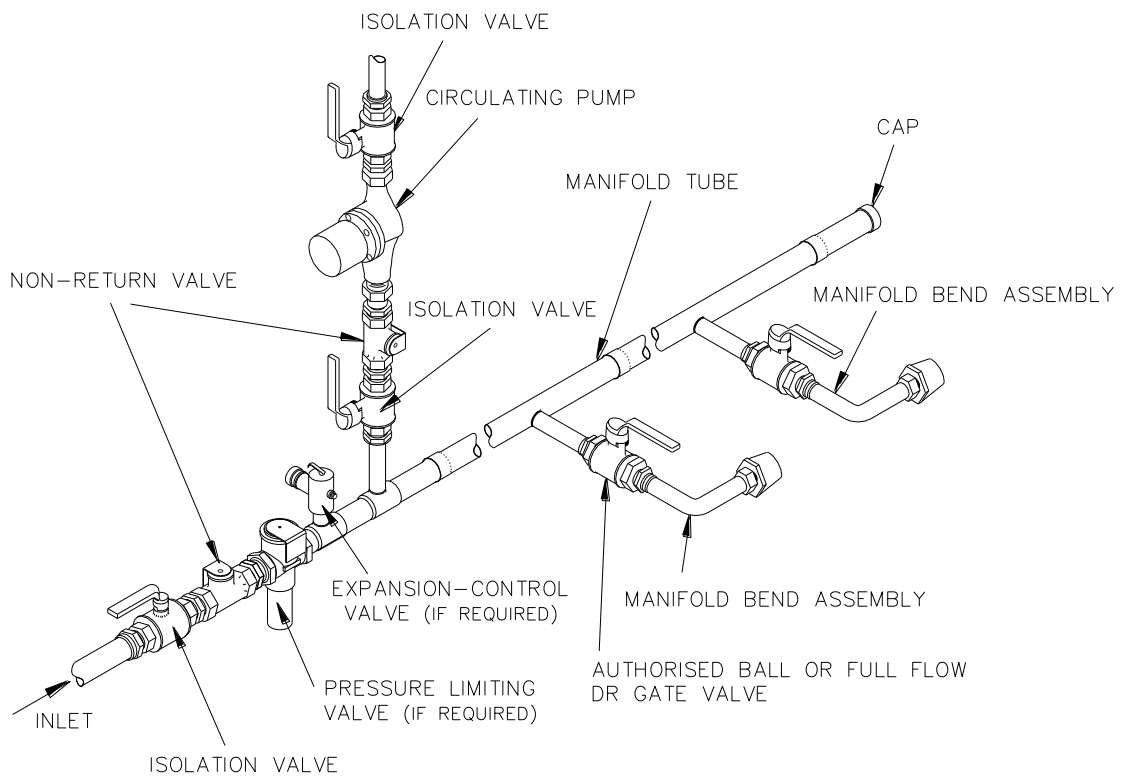

Cold Manifold Assembly

COMMISSIONING

TO FILL AND TURN ON THE WATER HEATER

The power supply to the water heater must not be switched on until the water heater is filled with water and a satisfactory megger reading is obtained.

- Open all of the hot water tap(s) in the building (don't forget the shower(s)) and supply cock(s) and valve(s) in the system.
- Open the isolation valves fully on the cold and hot water branches to the water heater(s) installed in a bank.
- Open the cold water isolation valve on the cold water line to the water heater(s).

Air will be forced out of the taps.

- Close each tap as water flows freely from it.
- Check the pipe work for leaks.
- Switch on the electrical supply at the isolating switch to the water heater(s).
- When the system has reached its working temperature, check the pipe work again for leaks.

Explain to the householder or a responsible officer the functions and operation of the water heater. Upon completion of the installation and commissioning of the water heater, leave this guide with the householder or a responsible officer.

TO TURN OFF THE WATER HEATER

If it is necessary to turn off the water heater on completion of the installation, such as on a building site or where the premises is vacant, then:

- Switch off the electrical supply at the isolating switch to the water heater(s).
- Close the cold water isolation valve on the cold water line to the water heater(s) to shut down the entire system, or;
- Close the isolation valves on the cold and hot water branches to shut down an individual water heater in a bank.

DRAINING THE WATER HEATER

⚠ Warning: Exercise care, as water discharged from the water heater may be of a very high temperature.

To drain the water heater:

- Turn off the water heater (refer to **"To Turn Off The Water Heater"** on page 28).
- Close all hot water taps.
- Operate the relief valve release lever - do not let the lever snap back or you will damage the valve seat.
Operating the lever will release the pressure in the water heater.
- Undo the union at the cold water inlet to the water heater and attach a hose to the water heater side of the union.

Let the other end of the hose go to a drain.

- Operate the relief valve again.

This will let air into the water heater and allow the water to drain through the hose.

This page is intentionally blank.

RHEEM HEAVY DUTY ELECTRIC MAINS PRESSURE WATER HEATER WARRANTY - AUSTRALIA ONLY

ELECTRIC WATER HEATER MODELS 613050, 613315, 616315

1. THE RHEEM WARRANTY – GENERAL

- 1.1 This warranty is given by Rheem Australia Pty Limited ABN 21 098 823 511 of 1 Alan Street, Rydalmere New South Wales.
- 1.2 Rheem offer a trained and qualified national service network who will repair or replace components at the address of the water heater subject to the terms of the Rheem warranty. Rheem Service, in addition can provide preventative maintenance and advice on the operation of your water heater. The Rheem Service contact number is available 7 days a week on 131031 with Service personnel available to take your call from 8am to 8pm daily (hours subject to change).
- 1.3 For details about this warranty, you can contact us on 131031 or by email at warrantyenquiry@rheem.com.au (not for service bookings).
- 1.4 The terms of this warranty are set out in section 2 and apply to water heaters manufactured after 1st December 2011.
- 1.5 If a subsequent version of this warranty is published, the terms of that warranty will apply to water heaters manufactured after the date specified in the subsequent version.

2. TERMS OF THE RHEEM WARRANTY AND EXCLUSIONS TO IT

- 2.1 The decision of whether to repair or replace a faulty component is at Rheem's sole discretion.
 - 2.2 If you require a call out and we find that the fault is not covered by the Rheem warranty, you are responsible for our standard call out charge. If you wish to have the relevant component repaired or replaced by Rheem, that service will be at your cost.
 - 2.3 Where a failed component or cylinder is replaced under this warranty, the balance of the original warranty period will remain effective. The replacement does not carry a new Rheem warranty.
 - 2.4 Where the water heater is installed outside the boundaries of a metropolitan area as defined by Rheem or further than 25 km from either a regional Rheem branch office or an Accredited Rheem Service Agent's office, the cost of transport, insurance and travelling between the nearest branch office or Rheem Accredited Service Agent's office and the installed site shall be the owner's responsibility.
 - 2.5 Where the water heater is installed in a position that does not allow safe or ready access, the cost of that access, including the cost of additional materials handling and/or safety equipment, shall be the owner's responsibility. In other words, the cost of dismantling or removing cupboards, doors or walls and the cost of any special equipment to bring the water heater to floor or ground level or to a serviceable position is not covered by this warranty.
 - 2.6 This warranty only applies to the original and genuine Rheem water heater in its original installed location and any genuine Rheem replacement parts.
 - 2.7 The Rheem warranty does not cover faults that are a result of:
 - a) Accidental damage to the water heater or any component (for example: (i) Acts of God such as floods, storms, fires, lightning strikes and the like; and (ii) third party acts or omissions).
 - b) Misuse or abnormal use of the water heater.
 - c) Installation not in accordance with the Owner's Guide and Installation Instructions or with relevant statutory and local requirements in the State or Territory in which the water heater is installed.
 - d) Connection at any time to a water supply that does not comply with the water supply guidelines as outlined in the Owner's Guide and Installation Instructions.
 - e) Repairs, attempts to repair or modifications to the water heater by a person other than Rheem Service or a Rheem Accredited Service Agent.
 - f) Faulty plumbing or faulty power supply.
 - g) Failure to maintain the water heater in accordance with the Owner's Guide and Installation Instructions.
 - h) Transport damage.
 - i) Fair wear and tear from adverse conditions (for example, corrosion).
 - j) Cosmetic defects.
 - 2.8 Subject to any statutory provisions to the contrary, this warranty excludes any and all claims for damage to furniture, carpet, walls, foundations or any other consequential loss either directly or indirectly due to leakage from the water heater, or due to leakage from fittings and/ or pipe work of metal, plastic or other materials caused by water temperature, workmanship or other modes of failure.
 - 2.9 If the water heater is not sized to supply the hot water demand in accordance with the guidelines in the Rheem water heater literature, any resultant fault will not be covered by the Rheem warranty.
-

RHEEM HEAVY DUTY ELECTRIC MAINS PRESSURE WATER HEATER WARRANTY - AUSTRALIA ONLY

ELECTRIC WATER HEATER MODELS 613050, 613315, 616315

3. WHAT IS COVERED BY THE RHEEM WARRANTY FOR THE WATER HEATERS DETAILED IN THIS DOCUMENT

3.1 Rheem will repair or replace a faulty component of your water heater if it fails to operate in accordance with its specifications as follows:

| What components are covered | The period from the date of installation in which the fault must appear in order to be covered | What coverage you receive |
|---|--|---|
| All components | Year 1 | Repair and/or replacement of the faulty component, free of charge, including labour. |
| The cylinder (if the water heater is installed in a single-family domestic dwelling with a thermostat setting below 76°C) | Years 2 to 5 | Repair and / or replacement of the cylinder, free of charge, including labour. |
| | Years 6 to 10 | Replacement cylinder, free of charge. Installation and repair labour costs are the responsibility of the owner. |
| The cylinder (if the water heater is <u>not</u> installed in a single-family domestic dwelling with a thermostat setting below 76°C) | Years 2 to 5 | Replacement cylinder, free of charge. Installation and repair labour costs are the responsibility of the owner. |

4. ENTITLEMENT TO MAKE A CLAIM UNDER THIS WARRANTY

4.1 To be entitled to make a claim under this warranty you need to:

- Be the owner of the water heater or have consent of the owner to act on their behalf.
- Contact Rheem Service without undue delay after detection of the defect and, in any event, within the applicable warranty period.

4.2 You are **not** entitled to make a claim under this warranty if your water heater:

- Does not have its original serial numbers or rating labels.
- Is not installed in Australia.

5. HOW TO MAKE A CLAIM UNDER THIS WARRANTY

5.1 If you wish to make a claim under this warranty, you need to:

- Contact Rheem on 131031 and provide owner's details, address of the water heater, a contact number and date of installation of the water heater or if that's unavailable, the date of manufacture and serial number (from the rating label on the water heater).
- Rheem will arrange for the water heater to be tested and assessed on-site.
- If Rheem determines that you have a valid warranty claim, Rheem will repair or replace the water heater in accordance with this warranty.

5.2 Any expenses incurred in the making of a claim under this warranty will be borne by you.

6. THE AUSTRALIAN CONSUMER LAW

6.1 Our goods come with guarantees that cannot be excluded under the *Australian Consumer Law*. You are entitled to a replacement or refund for a major failure and for compensation for any other reasonably foreseeable loss or damage. You are also entitled to have the goods repaired or replaced if the goods fail to be of acceptable quality and the failure does not amount to a major failure.

6.2 The Rheem warranty (set out above) is in addition to any rights and remedies that you may have under the *Australian Consumer Law*.

RHEEM AUSTRALIA PTY LTD, A.B.N. 21 098 823 511, www.rheem.com.au
For Service Telephone 131 031 AUSTRALIA or 0800 657 335 NEW ZEALAND