



# **readyhot**<sup>®</sup>

*water re-circulation pump specifications*

## **timeefficient**

*saves time waiting for the hot water to arrive*

## **waterefficient**

*save the water normally lost waiting for hot water to arrive*



*Saves water, energy and money*



**1300 365 116**  
[www.dux.com.au](http://www.dux.com.au)

# readyhot® water recirculation system

## Why the Dux Readyhot® system is preferred

- Heats the water in the pipes between the water heater and the hot water outlets before the outlets are opened.
- Saves water and reduces waiting time for heated water delivery from the outlet when opened.
- Traditional “flow and return” systems usually keep the water in the pipework continuously heated. Readyhot, however, only heats the water before the outlet is opened.
- This saves energy, as water is not heated unnecessarily, while keeping the benefits of flow and return systems.
- Suitable for all water types.

A schematic of the Readyhot system installed in conjunction with a Dux Endurance water heater and temperature controller is shown below.

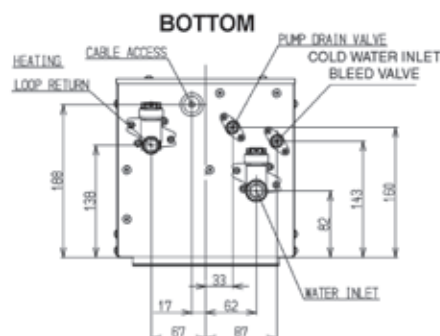
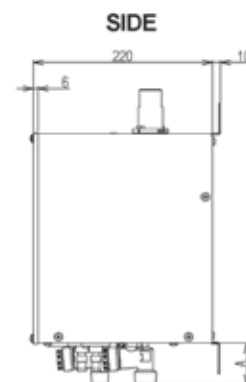
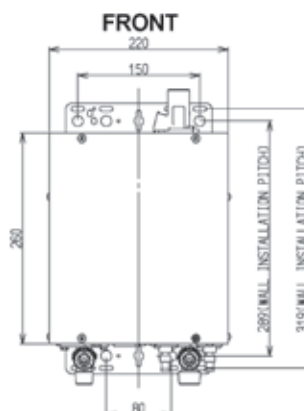
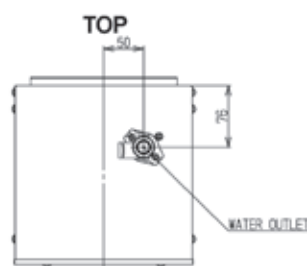
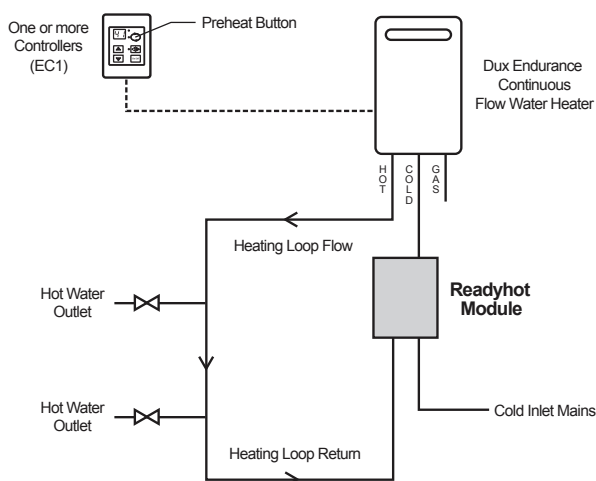

SPECIFICATIONS		
Weight (kg)	7.5	
Pump	Pump type	Centrifugal
	Current (Amps)	0.14
	Power consumption (Watts)	30
	Speed (RPM)	2700
	Watts – Standby Power	1
Connections	Water Outlet	R¾" – 20mm (Right)
	Heating Loop Return	R¾" – 20mm (Top)
	Water Inlet	R½" – 15mm (Left)
Water Operating pressure range	Maximum 500 kPa	
IP Rating	IPX4 (AS 1939)	
Power supply	AC 240 Volts 50 Hz (10 Amp power point required)	



## Contact Dux for your Hot Water Solutions

Sales: 1300 365 116 Service: 1300 365 115 Web Site: [www.dux.com.au](http://www.dux.com.au)  
 ©Dux Manufacturing Limited ABN 19 077 879 844. Lackey Rd, PO Box 209 Moss Vale, NSW 2577  
 The information supplied was correct at time of printing. Specification and materials may change without notice.  
 © and ™ indicate trademarks of Dux Manufacturing Limited. Dux Manufacturing Limited is part of a publicly listed Australian company.



GWA  
Smarter Solutions